

CERAMIC CHIP SPACERS WITHOUT METALLIZATION

TOP VIEW

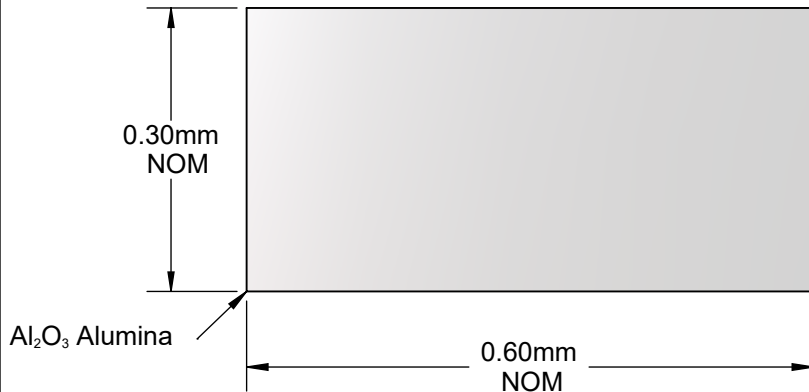

SIDE VIEW

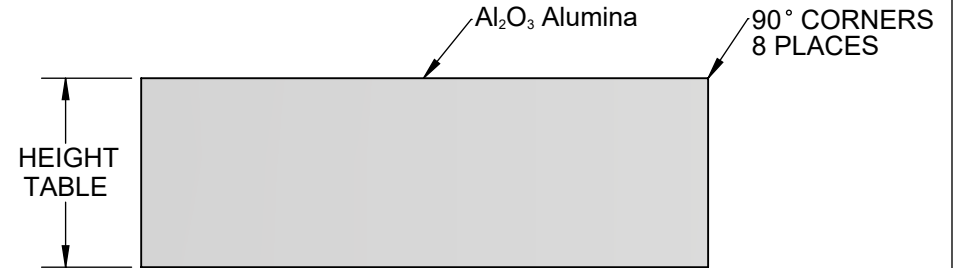

NOTES:

1. DIMENSION: mm EXCEPT AS NOTED.
2. METALLIZATION: NONE.
3. Pb-FREE AND HALOGEN FREE.
4. COLORS: WHITE and BLACK.

PART NUMBER	HEIGHT +/-0.025mm (1.0 mil)		
	mm	um	mil
SCC020108-D-E7A-W	0.20mm	200um	7.9mil
SCC020109-D-E7A-W	0.23mm	230um	9.0mil
SCC020110-D-E7A-W	0.25mm	250um	9.8mil
SCC020111-D-E7A-W	0.28mm	280um	11.0mil
SCC020112-D-E7A-W	0.31mm	310um	12.2mil
SCC020113-D-E7A-W	0.33mm	330um	13.0mil
SCC020114-D-E7A-W	0.35mm	350um	13.8mil
SCC020115-D-E7A-W	0.38mm	380um	15.0mil
SCC020116-D-E7A-W	0.40mm	400um	15.8mil
SCC020117-D-E7A-W	0.43mm	430um	17.0mil
SCC020118-D-E7A-W	0.46mm	460um	18.0mil
SCC020119-D-E7A-W	0.48mm	480um	19.0mil
SCC020120-D-E7A-W	0.50mm	500um	19.7mil

MODELS

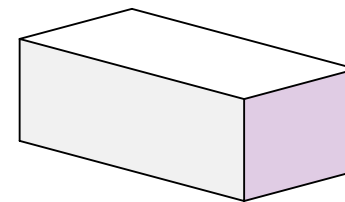

WHITE

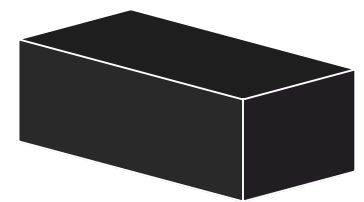

BLACK

NOTES:

1. OTHER SIZES AND HEIGHTS AVAILABLE.
2. CARRIER TAPE CODE SUBJECT TO CHANGE from E7A to P7A.

APPROVALS	DATE	TopLine®			
DRAWN T. Au	12/12/2023				
ENG M. Hart	12/12/2023	TITLE SCC0201 CERAMIC SPACERS NON METALLIZED			
MFG		SCALE	SIZE	DRAWING NO.	REV
QA		125:1	A	020104	B
CUST		DO NOT SCALE DRAWING			SHEET 1 OF 4
REVISED					

PART NUMBERING SYSTEM



SCC =
CERAMIC
CHIP
NON-METALLIZED

0201 =
0.6x 0.3mm
NOMINAL
±0.05mm

HEIGHT CODE

08 = 0.20mm
09 = 0.23mm
10 = 0.25mm
11 = 0.28mm
12 = 0.31mm
13 = 0.33mm
14 = 0.35mm
15 = 0.38mm
16 = 0.40mm
17 = 0.43mm
18 = 0.46mm
19 = 0.48mm
20 = 0.50mm
Other Available

HEIGHT TOLERANCE

D = ± 0.025mm
± 1.0mil

C = ±0.013mm
±0.5mil

BLANK = HEIGHT
TOLERANCE
NOT STATED

PACKAGING

E7A = PLASTIC
CARRIER TAPE
AND REEL

P7A = PAPER
CARRIER TAPE
AND REEL

B = BULK

E = CUT TAPE
WITHOUT REEL

W = 2" WAFFLE
PACK

COLOR

W = WHITE
B = BLACK

TopLine®

TITLE SCC0201 CERAMIC SPACERS
NON METALLIZED

SCALE NONE	SIZE A	DRAWING NO. 020104	REV B
---------------	-----------	-----------------------	----------

DO NOT SCALE DRAWING

SHEET 2 OF 4

W8P2 CARRIER TAPE DIMENSION

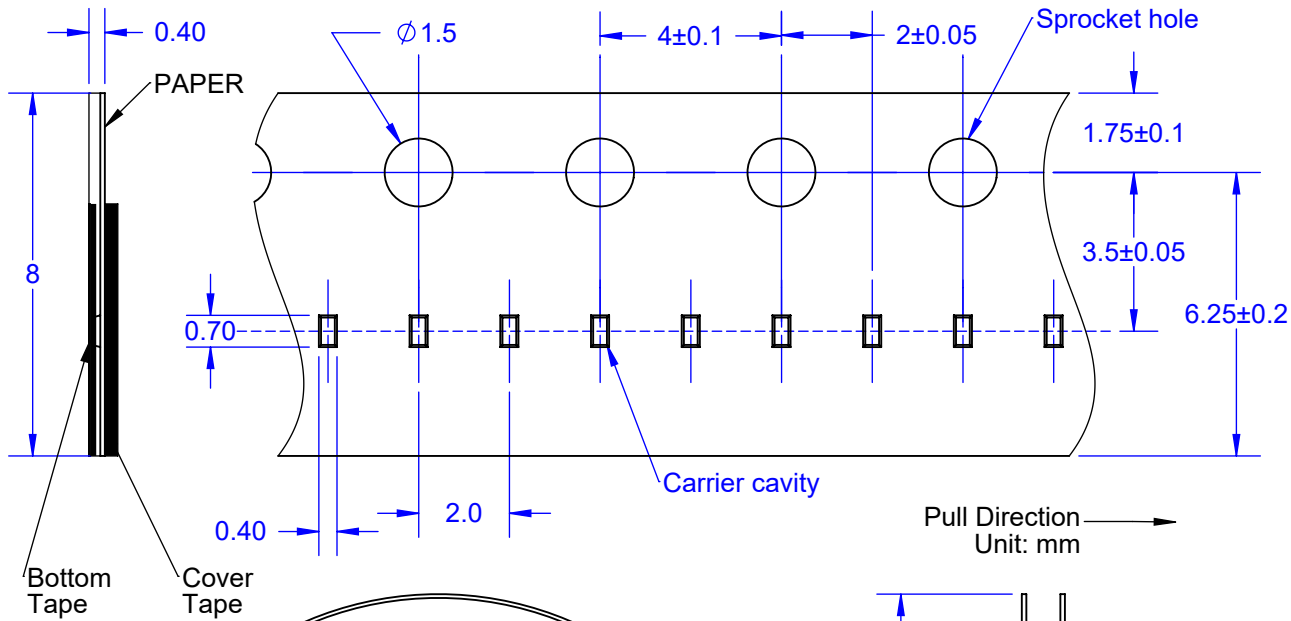

PACK CODE			
CODE	0201	PACKAGE	TAPE
P7A	3,000	REEL	PAPER
P4A	1,000	REEL	PAPER

Pull Direction
Unit: mm

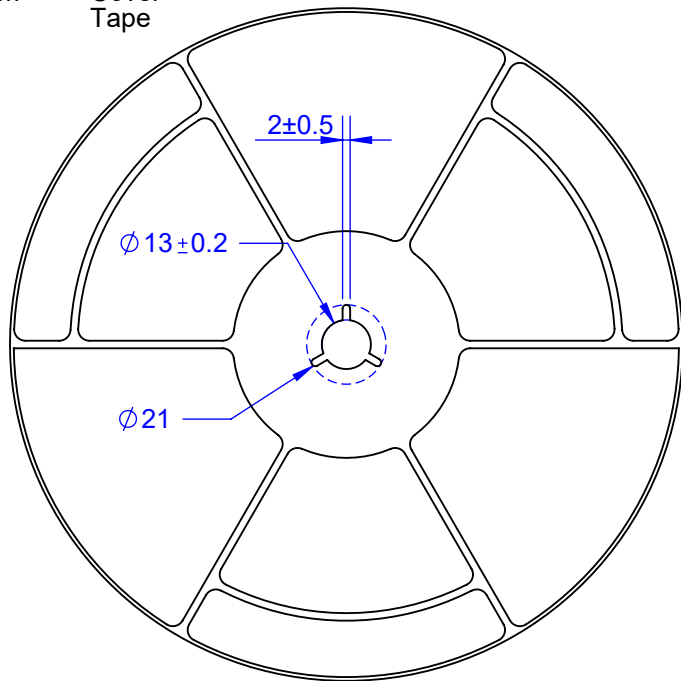

REEL DIMENSIONS

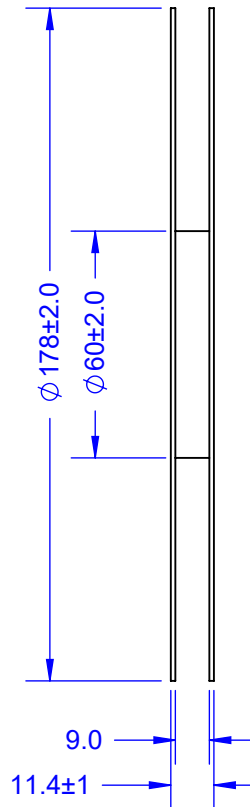

REVISED

			
TITLE SCC0201 PRECISION HEIGHT NON METALIZED CHIPS			
SCALE NONE	SIZE A	DRAWING NO. 020104	REV B
DO NOT SCALE DRAWING			SHEET 3 OF 4

W8P4 CARRIER TAPE DIMENSION

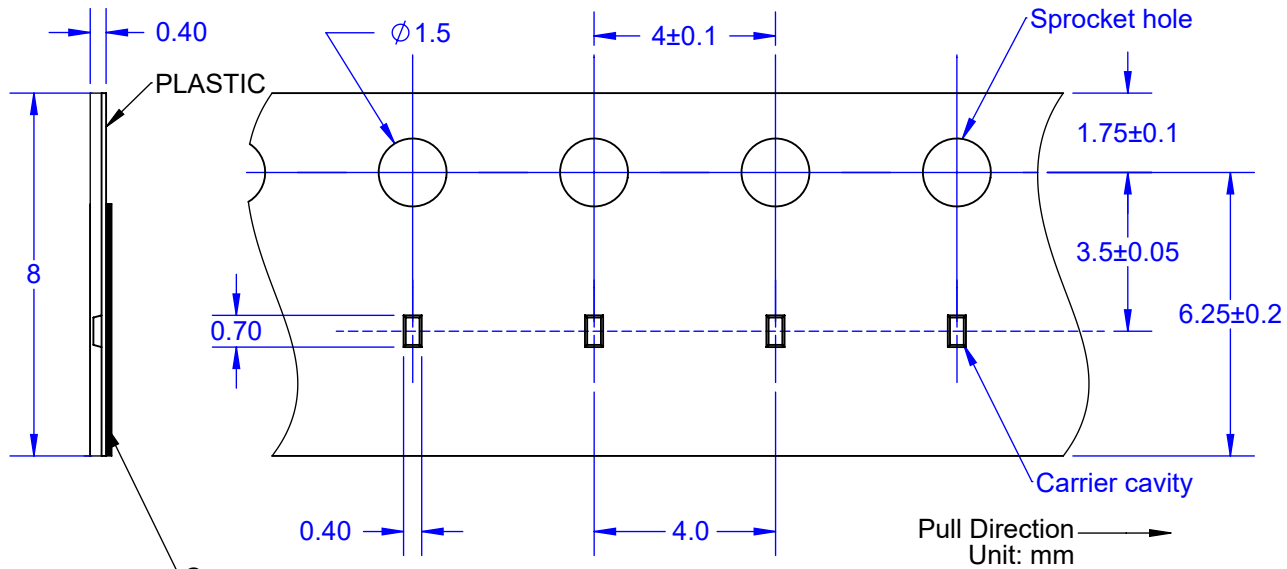

PACK CODE			
CODE	0201	PACKAGE	TAPE
E7A	3,000	REEL	PLASTIC
E4A	1,000	REEL	PLASTIC

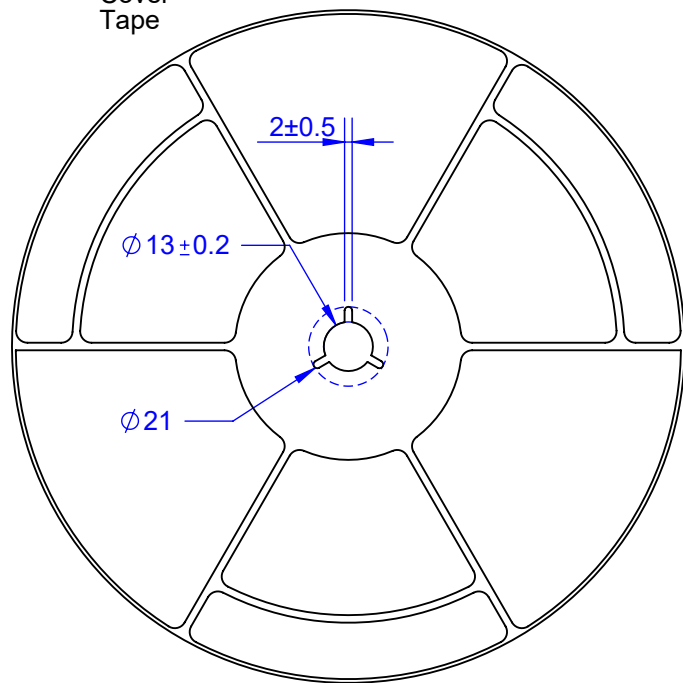

REEL DIMENSIONS

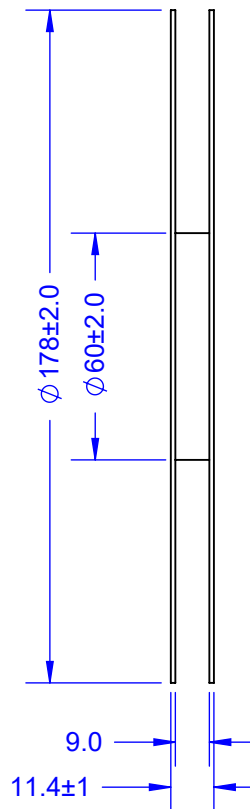

REVISED

TopLine®			
TITLE SCC0201 PRECISION HEIGHT NON METALIZED CHIPS			
SCALE NONE	SIZE A	DRAWING NO. 020104	REV B
DO NOT SCALE DRAWING			SHEET 4 OF 4