

WHITE AND BLACK CHIPS WITHOUT METALLIZATION

TOP VIEW

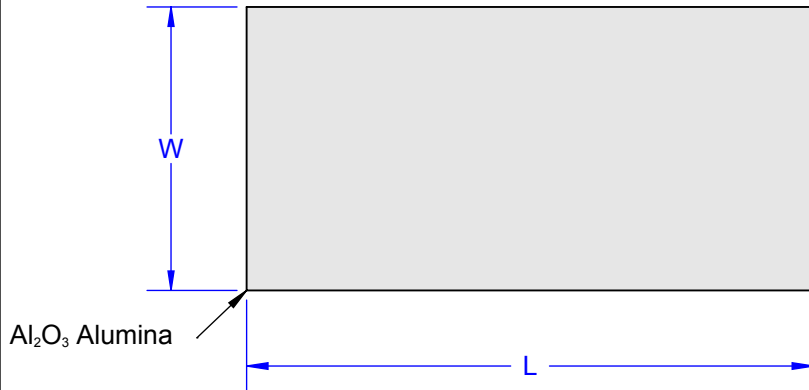

SIDE VIEW

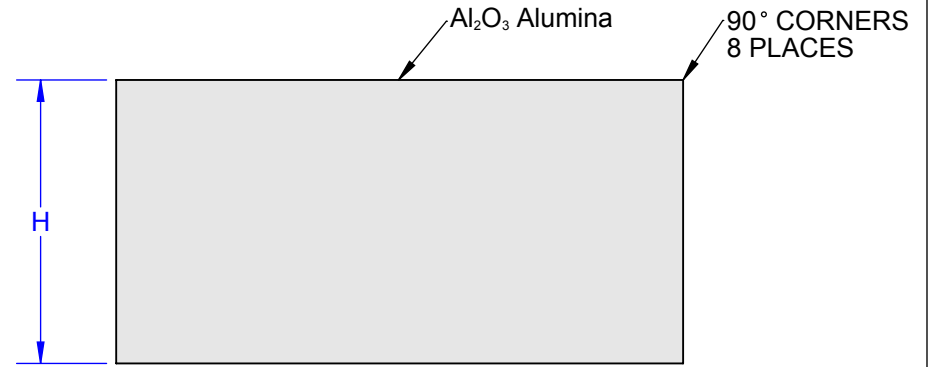

NOTES:

1. DIMENSION IN mm EXCEPT AS NOTED.
2. METALLIZATION: NONE.
3. Pb-FREE AND HALOGEN FREE.
4. COLORS: WHITE and BLACK.

PART NUMBER TABLE

SIZE CODE	COLOR	PART SERIES	SIZE (MM)				TOLERANCE	OUTLINE DRAWING
			L LENGTH	W WIDTH	H HEIGHT			
0402	WHITE	SCC0402P7A-WHITE	1.00	0.50	0.50	±0.076	040210	
0402	BLACK	SCC0402P7A-BLACK	1.00	0.50	0.50	±0.076	040211	

MODELS

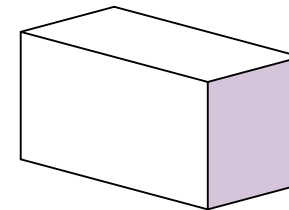

WHITE

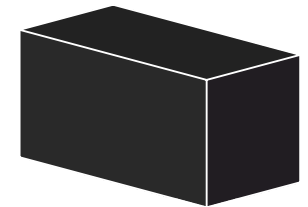

BLACK

APPROVALS	DATE	TopLine®			
DRAWN T. Au	07/28/14				
ENG M. Hart	07/28/14	TITLE SCC0402 UNTERMINATED CHIPS			
MFG		SCALE	SIZE	DRAWING NO.	REV
QA		75:1	A	040210	A
CUST		DO NOT SCALE DRAWING			SHEET 1 OF 2
REVISED					

W8P2 CARRIER TAPE DIMENSION

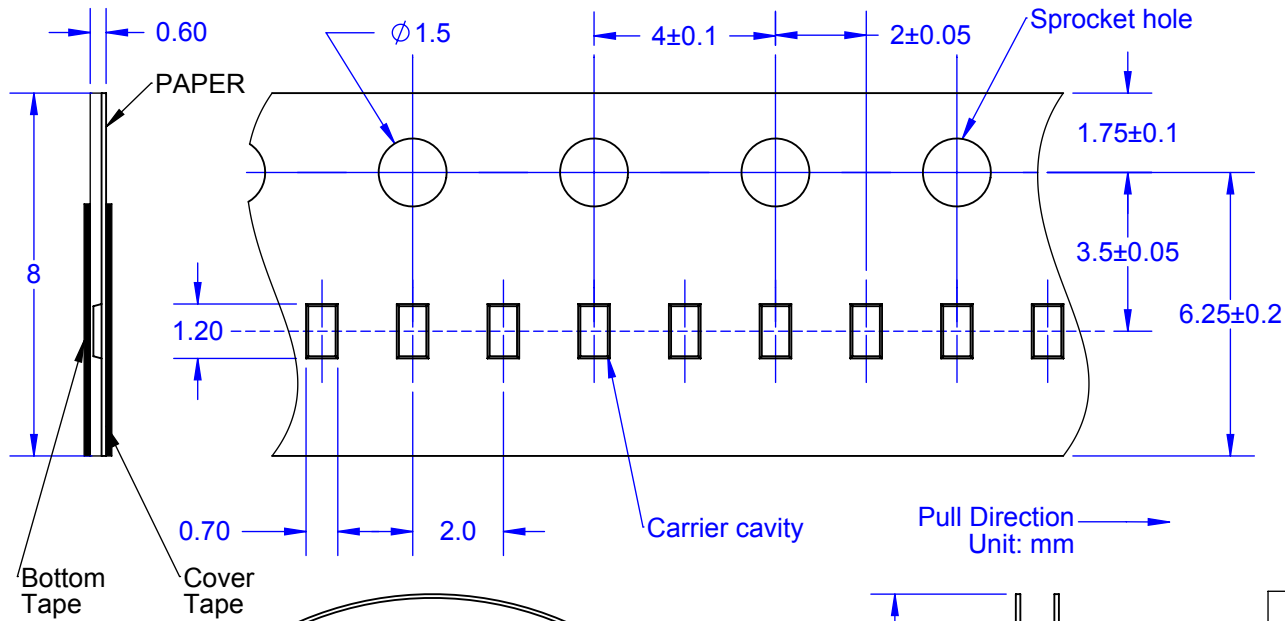

PART NUMBER SYSTEM

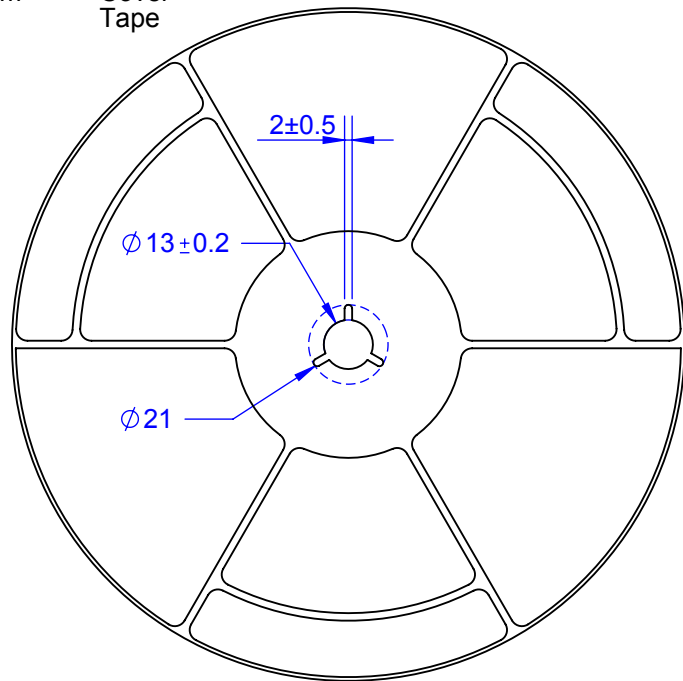
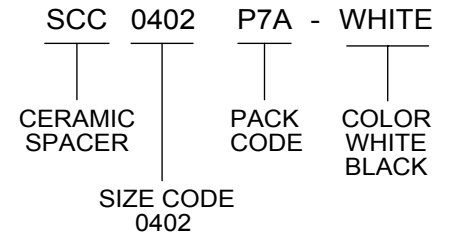

REEL DIMENSIONS

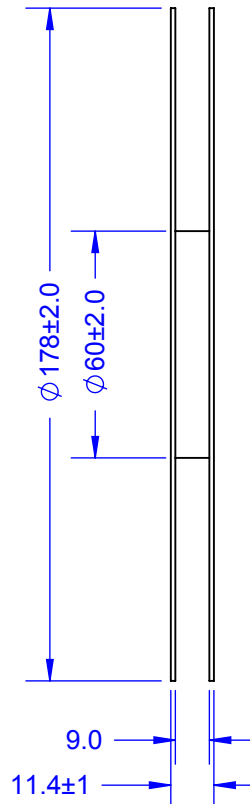

PACK CODE			
CODE	0402	PACKAGE	TAPE
P7A	10,000	REEL	PAPER
P4A	1,000	REEL	PAPER

APPROVALS	DATE				
DRAWN T. Au	07/28/14				
ENG M. Hart	07/28/14	TITLE			
MFG		SCC0402 UNTERMINATED CHIPS			
QA		SCALE	SIZE	DRAWING NO.	REV
CUST		NONE	A	040210	A
REVISED		DO NOT SCALE DRAWING			SHEET 2 OF 2