

WIRE BONDING PAD

DETAIL 1

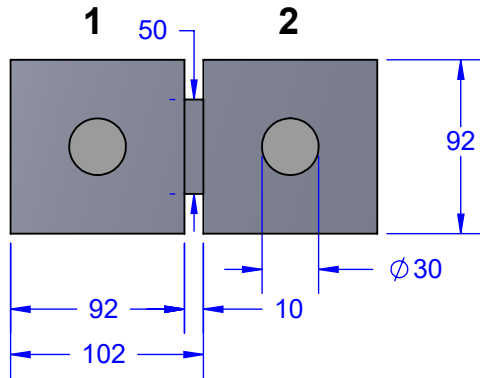

DETAIL 2

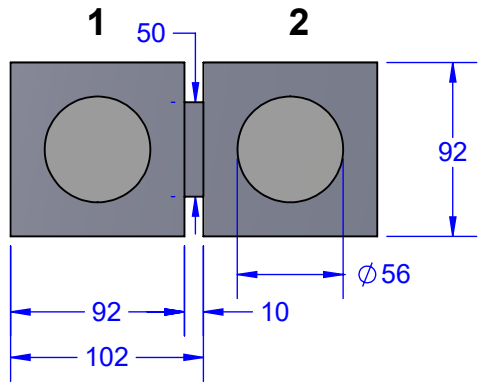

DETAIL 3

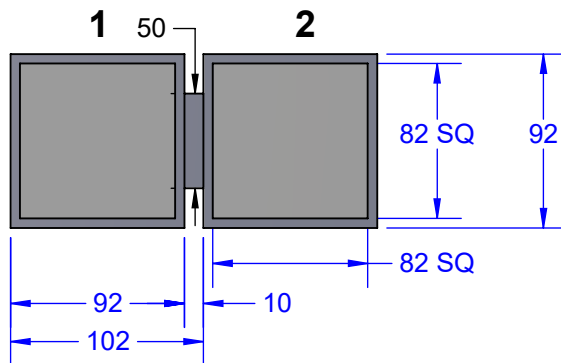

DETAIL 1
DETAIL 2
DETAIL 3

DAISY CHAIN PATTERN PAD VIEW

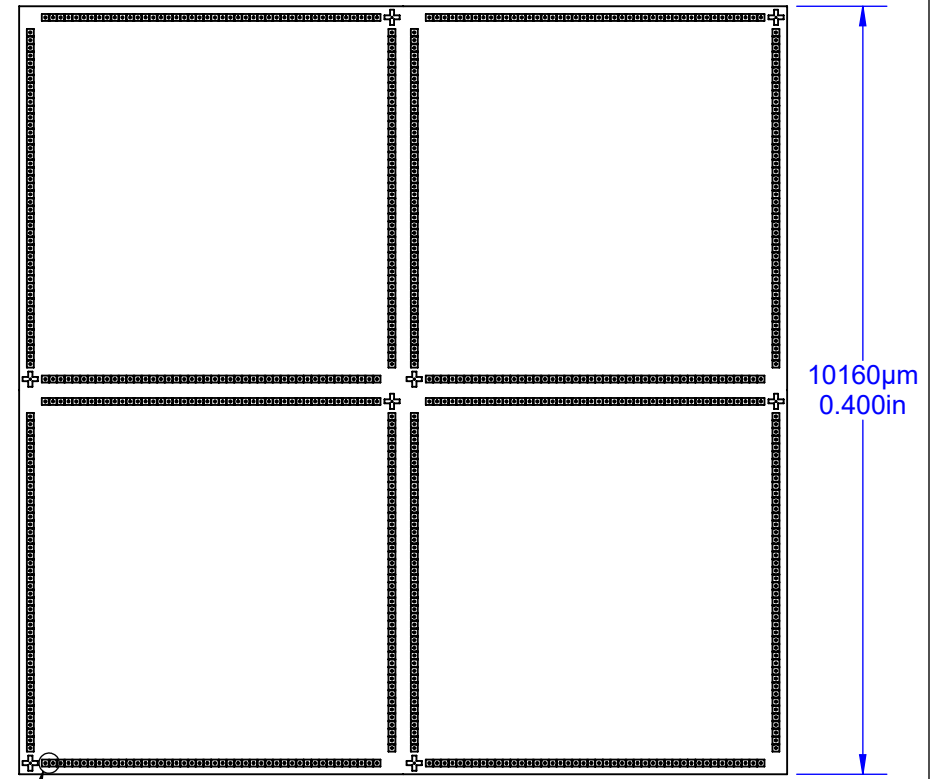

NOTES:

- 1) DIMENSIONS IN MICRONS (μM) OR AS SPECIFIED.
- 2) THICKNESS: $635\mu\text{m}$ (OTHER AVAILABLE).
- 3) PASSIVATION: NITRIDE 8KA THICKNESS ($0.8\mu\text{m}$).
- 4) PACKAGING: STANDARD WAFFLE PACK (TRAY).
- 5) PAD METAL THICKNESS: 9KA ($0.9\mu\text{m}$).

PART NUMBER TABLE

PART NUMBER	DIE SIZE	DIE PER WAFER	BOND SITE	DETAIL
FCN352M10A102-DC	10mm	86	$\varnothing 30\mu\text{m}$	1
FCN352L10A102-DC	10mm	86	$\varnothing 56\mu\text{m}$	2
FCN352J10A102-DC	10mm	86	82 μm SQ	3

APPROVALS		DATE				
DRAWN	T. Au	9/20/2021				
ENG	M. Hart	9/20/2021	TITLE		FCN352 - 102UM PITCH DAISY CHAIN DIE	
MFG			SCALE	SIZE	DRAWING NO.	REV
QA			10:1	A	648810	A
CUST			DO NOT SCALE DRAWING			SHEET 1 OF 6
REVISED						

OUTLINE DIMENSIONS

BACK SIDE

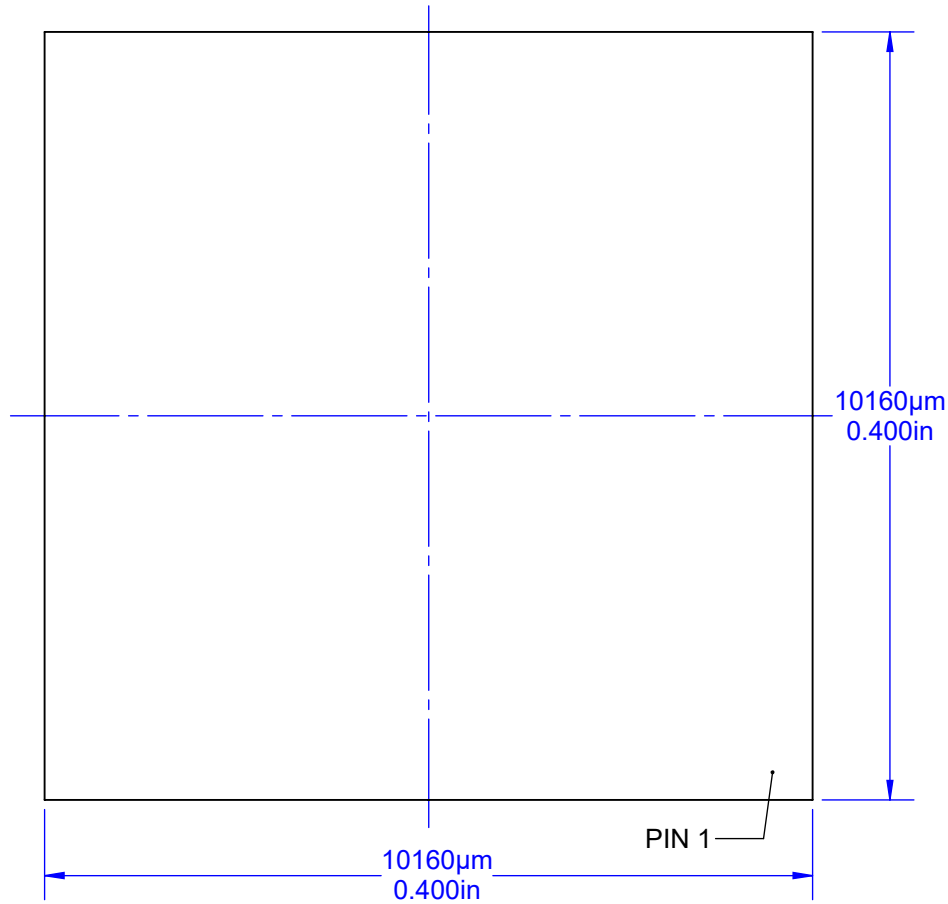

PAD SIDE

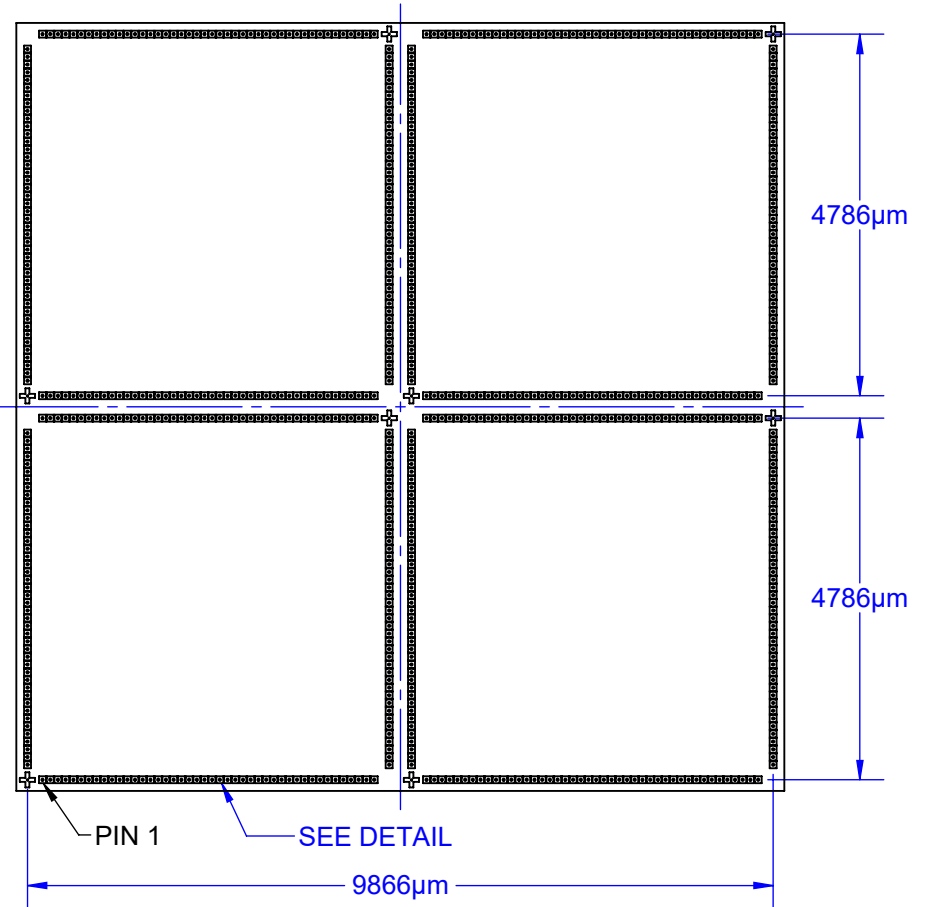

DETAIL 1

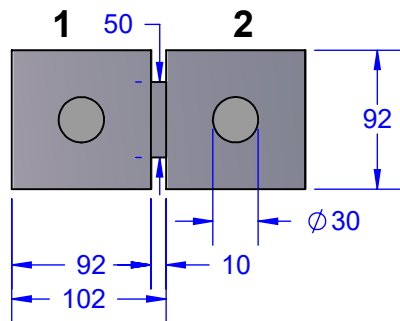

DETAIL 2

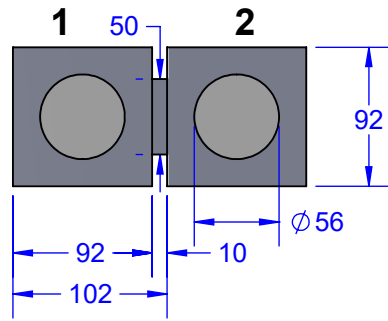

DETAIL 3

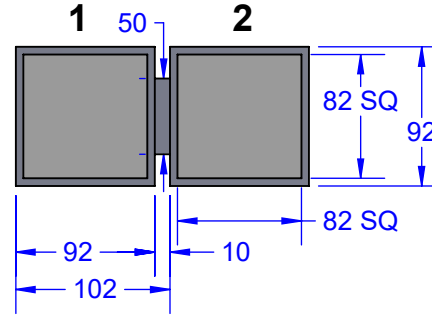

TopLine®

TITLE			
FCN352 - 102UM PITCH DAISY CHAIN DIE			
SCALE	SIZE	DRAWING NO.	REV
17.5:1	A	648810	A
DO NOT SCALE DRAWING			SHEET 2 OF 6

DETAIL A PAD LOCATION DIMENSION MICRON (μM)

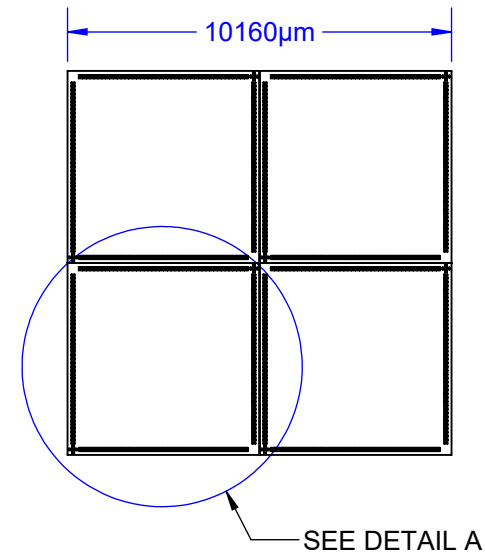
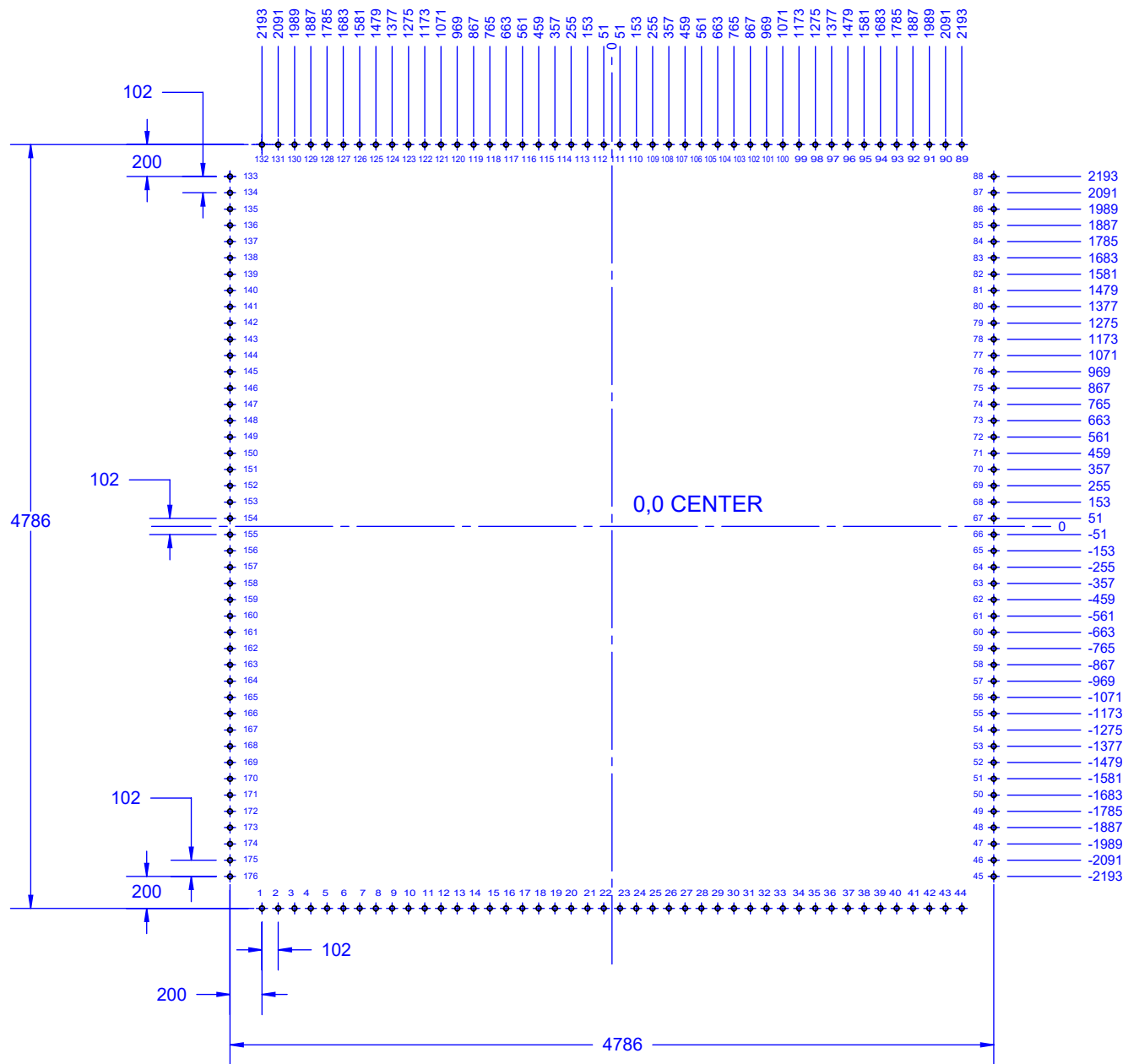

- NOTES:
 1) DIMENSIONS IN MICRONS (μM).
 2) X=0, Y=0 IS CENTER OF DIE.
 3) SEE NET LIST PAGE 6.

TopLine[®]			
TITLE FCN352 - 102UM PITCH DAISY CHAIN DIE			
SCALE 10:1	SIZE A	DRAWING NO. 648810	REV A
DO NOT SCALE DRAWING			SHEET 3 OF 6

DETAIL B BONDING MAP SEE NET LIST (PAGE 5)

132 131 130 129 128 127 126 125 124 123 122 121 120 119 118 117 116 115 114 113 112 111 110 109 108 107 106 105 104 103 102 101 100 99 98 97 96 95 94 93 92 91 90 89

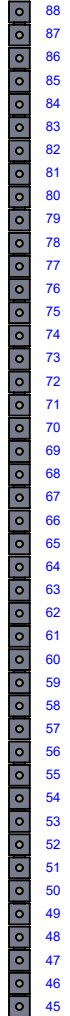
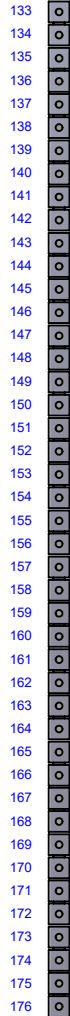

0,0 CENTER
+
—



1 2 3 4 5 6 7 8 9 10 11 12 13 14 15 16 17 18 19 20 21 22 23 24 25 26 27 28 29 30 31 32 33 34 35 36 37 38 39 40 41 42 43 44

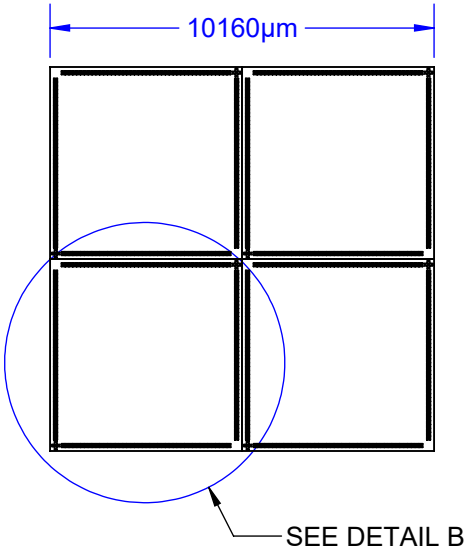

TopLine®			
TITLE FCN352 - 102UM PITCH DAISY CHAIN DIE			
SCALE 25:1	SIZE A	DRAWING NO. 648810	REV A
DO NOT SCALE DRAWING		SHEET 4 OF 6	

**FCN176 NET LIST
MICRON (μM)
(0,0) LOCATED AT THE CENTER OF THE DIE**

PIN#	X	Y
1	-2193	-2393
2	-2091	-2393
3	-1989	-2393
4	-1887	-2393
5	-1785	-2393
6	-1683	-2393
7	-1581	-2393
8	-1479	-2393
9	-1377	-2393
10	-1275	-2393
11	-1173	-2393
12	-1071	-2393
13	-969	-2393
14	-867	-2393
15	-765	-2393
16	-663	-2393
17	-561	-2393
18	-459	-2393
19	-357	-2393
20	-255	-2393
21	-153	-2393
22	-51	-2393
23	51	-2393
24	153	-2393
25	255	-2393
26	357	-2393
27	459	-2393
28	561	-2393
29	663	-2393
30	765	-2393
31	867	-2393
32	969	-2393
33	1071	-2393
34	1173	-2393
35	1275	-2393
36	1377	-2393
37	1479	-2393
38	1581	-2393
39	1683	-2393
40	1785	-2393
41	1887	-2393
42	1989	-2393
43	2091	-2393
44	2193	-2393

PIN#	X	Y
45	2393	-2193
46	2393	-2091
47	2393	-1989
48	2393	-1887
49	2393	-1785
50	2393	-1683
51	2393	-1581
52	2393	-1479
53	2393	-1377
54	2393	-1275
55	2393	-1173
56	2393	-1071
57	2393	-969
58	2393	-867
59	2393	-765
60	2393	-663
61	2393	-561
62	2393	-459
63	2393	-357
64	2393	-255
65	2393	-153
66	2393	-51
67	2393	51
68	2393	153
69	2393	255
70	2393	357
71	2393	459
72	2393	561
73	2393	663
74	2393	765
75	2393	867
76	2393	969
77	2393	1071
78	2393	1173
79	2393	1275
80	2393	1377
81	2393	1479
82	2393	1581
83	2393	1683
84	2393	1785
85	2393	1887
86	2393	1989
87	2393	2091
88	2393	2193

PIN#	X	Y
89	2193	2393
90	2091	2393
91	1989	2393
92	1887	2393
93	1785	2393
94	1683	2393
95	1581	2393
96	1479	2393
97	1377	2393
98	1275	2393
99	1173	2393
100	1071	2393
101	969	2393
102	867	2393
103	765	2393
104	663	2393
105	561	2393
106	459	2393
107	357	2393
108	255	2393
109	153	2393
110	51	2393
111	-51	2393
112	-153	2393
113	-255	2393
114	-357	2393
115	-459	2393
116	-561	2393
117	-663	2393
118	-765	2393
119	-867	2393
120	-969	2393
121	-1071	2393
122	-1173	2393
123	-1275	2393
124	-1377	2393
125	-1479	2393
126	-1581	2393
127	-1683	2393
128	-1785	2393
129	-1887	2393
130	-1989	2393
131	-2091	2393
132	-2193	2393

PIN#	X	Y
133	-2393	2193
134	-2393	2091
135	-2393	1989
136	-2393	1887
137	-2393	1785
138	-2393	1683
139	-2393	1581
140	-2393	1479
141	-2393	1377
142	-2393	1275
143	-2393	1173
144	-2393	1071
145	-2393	969
146	-2393	867
147	-2393	765
148	-2393	663
149	-2393	561
150	-2393	459
151	-2393	357
152	-2393	255
153	-2393	153
154	-2393	51
155	-2393	-51
156	-2393	-153
157	-2393	-255
158	-2393	-357
159	-2393	-459
160	-2393	-561
161	-2393	-663
162	-2393	-765
163	-2393	-867
164	-2393	-969
165	-2393	-1071
166	-2393	-1173
167	-2393	-1275
168	-2393	-1377
169	-2393	-1479
170	-2393	-1581
171	-2393	-1683
172	-2393	-1785
173	-2393	-1887
174	-2393	-1989
175	-2393	-2091
176	-2393	-2193

NOTES:
1) DIMENSIONS IN MICRON (μM).
2) X = 0, Y = 0 IS CENTER OF DIE.

			
TITLE FCN352 - 102UM PITCH DAISY CHAIN DIE			
SCALE 10:1	SIZE A	DRAWING NO. 648810	REV A
DO NOT SCALE DRAWING			SHEET 5 OF 6

PART NUMBERING SYSTEM

FCN

352

J

10

A

102

- OPTION

- DC

- PACKING

BONDING DIE

FCN = SINGLE DIE
 FCWN = UNSAWN WAFER
 5" (125mm)

NBR BOND PADS

PADS	DIE ARRAY	SIZE
176	1X	5MM
352	4X	10MM
528	9X	15MM
704	16X	20MM

PAD

M = \varnothing 30 μ M
 L = \varnothing 56 μ M
 J = 82 μ M SQ

DIE SIZE

CODE	MM	MIL
5	5.08	200
10	10.16	400
15	15.24	600
20	20.32	800

PAD MATERIAL

A = Al98, Si1.0 Cu1.0

BUMP PITCH

μ M

OPTIONS

CODE	DIE THINNING	
	μ M	INCH
NONE	635 μ M	.025"
BG530	530 μ M	.021"
BG430	430 μ M	.017"
BG360	360 μ M	.014"
BG250	250 μ M	.010"
BG200	200 μ M	.008"
BG150	150 μ M	.006"
BG100	100 μ M	.004"

OTHER THICKNESS AVAILABLE

DAISY CHAIN

PACKAGING

BLANK = TRAY (STANDARD)

SIZE	TRAY	QTY
5MM	2-INCH	36 PCS
10MM	4-INCH	49 PCS
15MM	4-INCH	25 PCS
20MM	4-INCH	9 PCS



TITLE FCN352 - 102UM PITCH DAISY CHAIN DIE			
SCALE 10:1	SIZE A	DRAWING NO. 648810	REV A
DO NOT SCALE DRAWING		SHEET 6 OF 6	