

**SECTION A-A**  
**SCALE 3 : 1**

Notes: (Unless Otherwise Specified).

- 1) DIMENSIONS: INCH [mm].
- 2) FLAT LEADS ALLOY 42.
- 3) FINAL FINISH: GOLD Au 60-MICRO-INCHES, Ni 100-MICRO-INCHES NOMINAL .
- 4) WITH LID

<b>TopLine®</b>			
TITLE		48 PIN FLAT PACK FP48F50R.64x1.31T	
SCALE	SIZE	DRAWING NO.	REV
3:1	A	194852	A
DO NOT SCALE DRAWING			SHEET 1 OF 3

# MODEL WITH LID

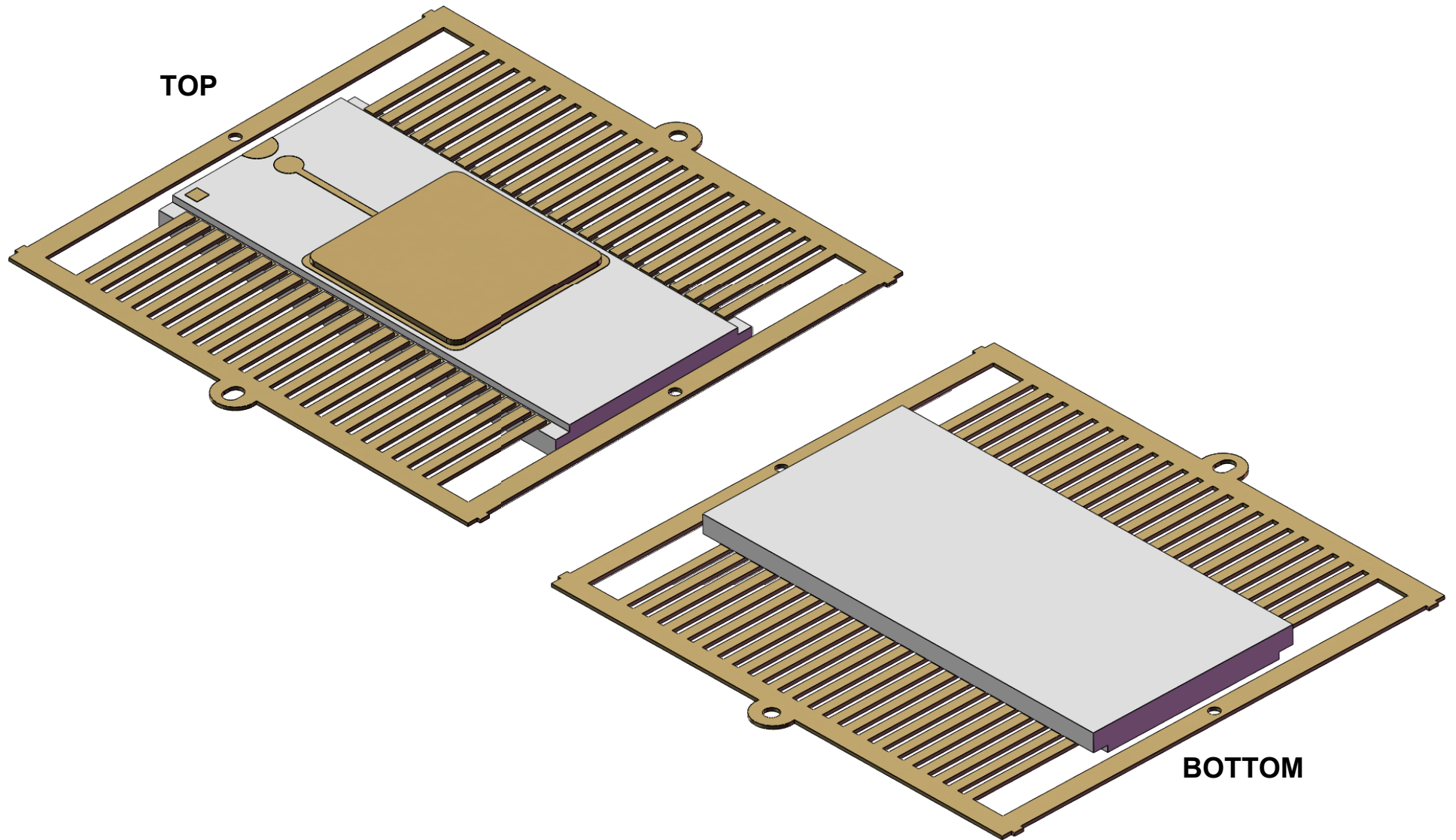

<b>TopLine<sup>®</sup></b>			
TITLE		52 PIN FLAT PACK FP52F50R.64x1.31T	
SCALE	SIZE	DRAWING NO.	REV
3:1	A	167166	A
DO NOT SCALE DRAWING			SHEET 2 OF 3

# DAISY CHAIN OPTIONAL

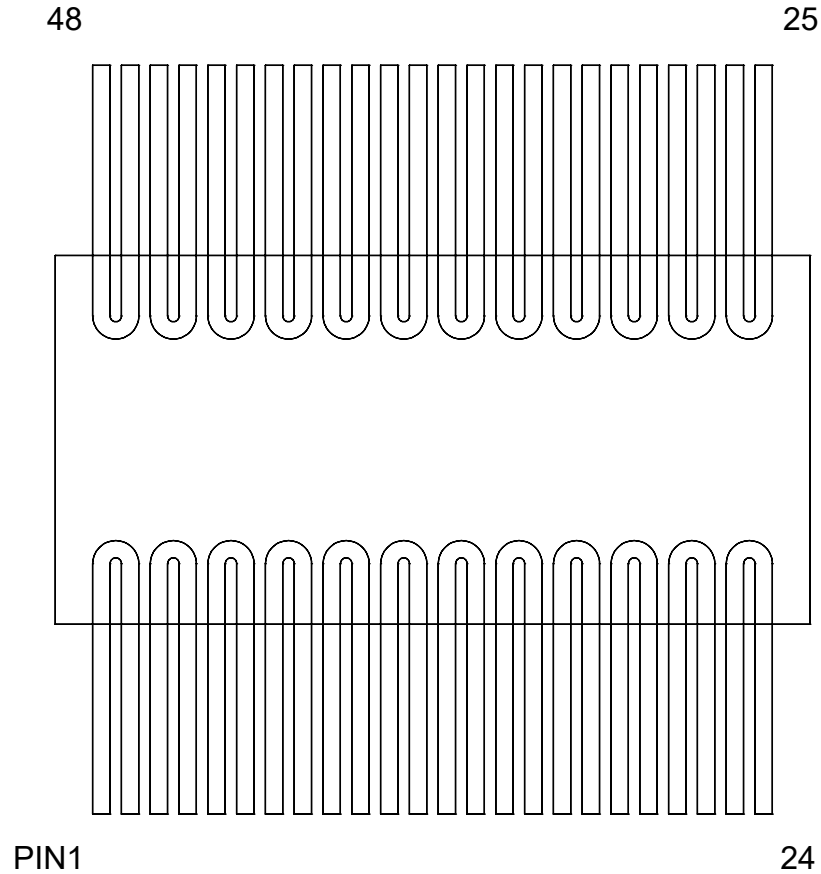

DAISY CHAIN NETLIST	
PINS	PINS
1 ~ 2	25 ~ 26
3 ~ 4	27 ~ 28
5 ~ 6	29 ~ 30
7 ~ 8	31 ~ 32
9 ~ 10	33 ~ 34
11 ~ 12	35 ~ 36
13 ~ 14	37 ~ 38
15 ~ 16	39 ~ 40
17 ~ 18	41 ~ 42
19 ~ 20	43 ~ 44
21 ~ 22	45 ~ 46
23 ~ 24	47 ~ 48

**TopLine®**

TITLE      48 PIN FLAT PACK  
FP48F50R.64x1.31T

SCALE 3:1	SIZE A	DRAWING NO. 194852	REV A
--------------	-----------	-----------------------	----------

DO NOT SCALE DRAWING

SHEET 3 OF 3