

TOP VIEW

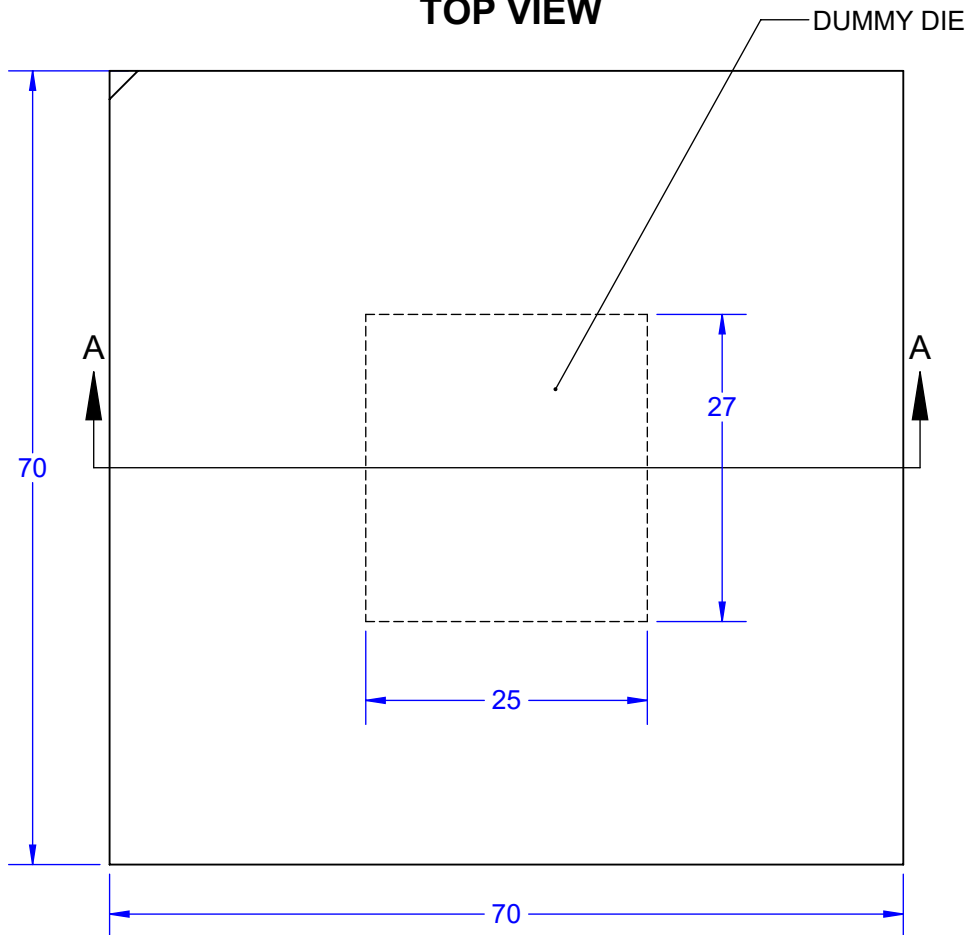

BOTTOM VIEW

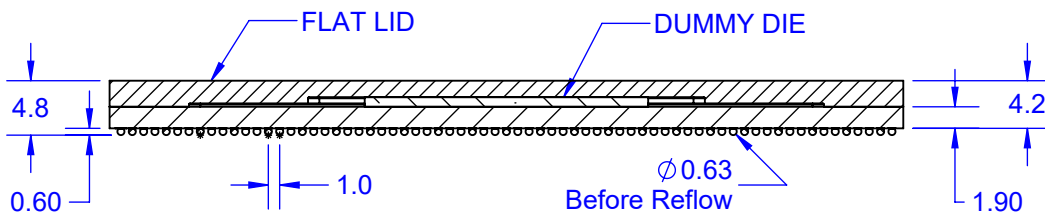
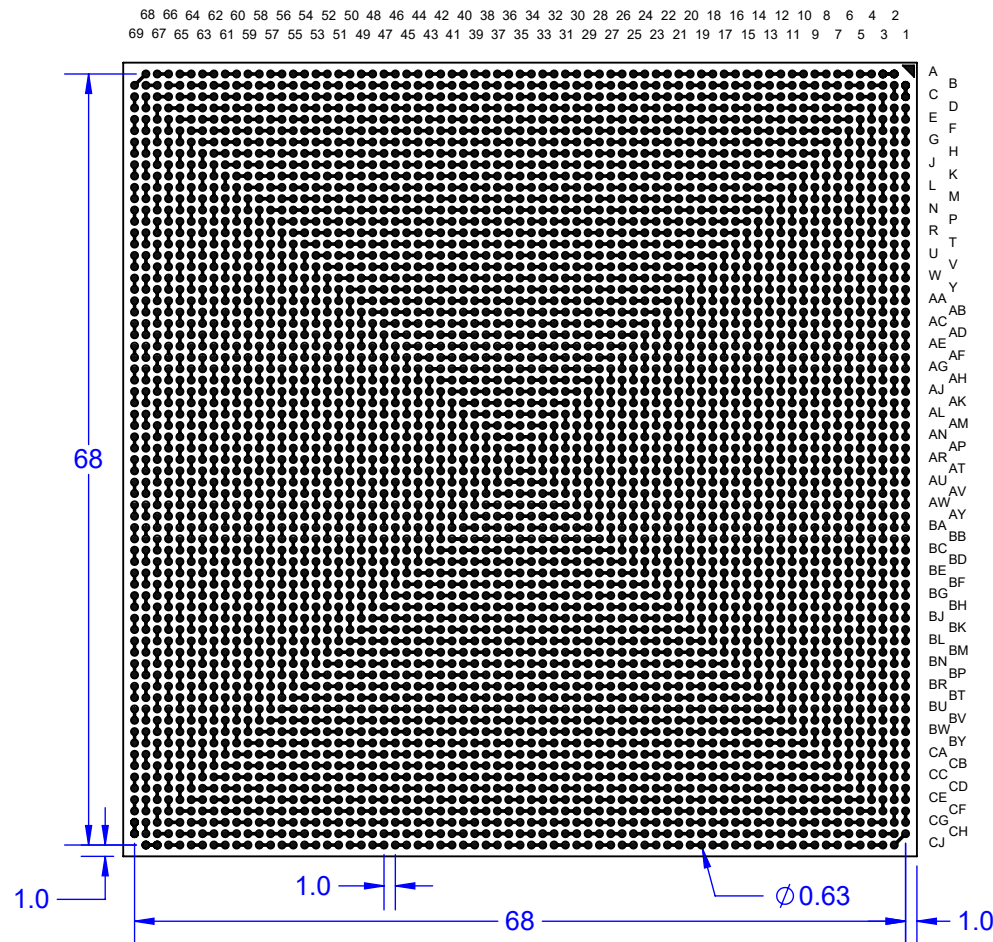

SECTION A-A

Notes: (Unless Otherwise Specified).

- 1) ALL DIMENSIONS ARE IN MM.
- 2) SOLDER BALL ALLOY: SEE PART NUMBER TABLE.
- 3) BALL DIAMETER (BEFORE REFLOW): 0.635mm (25 MIL).
- 4) SOLDER MASK DEFINED PAD OPENING: 0.50mm (19.7 MIL).
- 5) PAD Cu DIAMETER: 0.635mm (25 MIL).
- 6) SUBSTRATE MATERIAL: ORGANIC.
- 7) DUMMY DIE Si (SILICON) 25 x 27mm.
- 8) DAISY CHAIN PATTERN (SEE PAGE 2).
- 9) MSL-3 RECOMMENDED BAKING 24 HOURS @ 125°C TO REMOVE MOISTURE PRIOR SOLDERING TO PC BOARD.

PART NUMBER TABLE

PART NUMBER	BALL ALLOY	BALL ALLOY	RoHS	Si DIE
FBGA4757T1.0C-DC698D	Sn96.5/Ag3.0/Cu0.5	SAC305	YES	YES
FBGA4757T1.0-DC698D	Sn63/Pb37	Sn63	NO	YES

APPROVALS	DATE	TopLine®			
DRAWN T. Au	2/12/2023				
ENG M. Hart	2/12/2023	TITLE FBGA4757T1.0C-DC698D DAISY CHAIN DUMMY			
MFG		SCALE 3:2	SIZE A	DRAWING NO. 516985	REV A
QA		DO NOT SCALE DRAWING			SHEET 1 OF 6
CUST					
REVISED					

BOTTOM SIDE (TOP X-RAY VIEW)

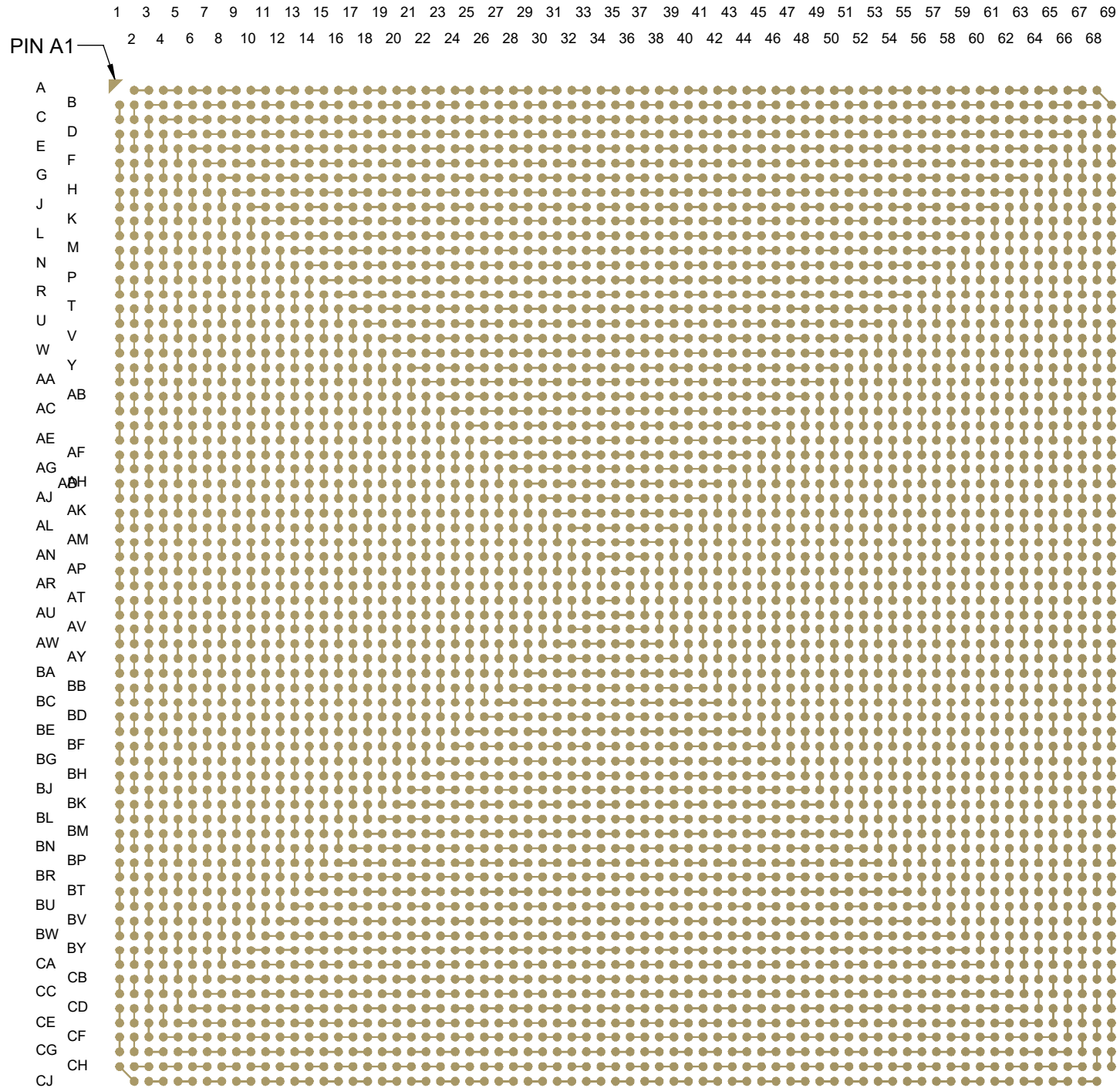

TopLine®			
TITLE FBGA4757T1.0C-DC698D DAISY CHAIN DUMMY			
SCALE	SIZE	DRAWING NO.	REV
2.5:1	A	516985	A
DO NOT SCALE DRAWING			SHEET 3 OF 6

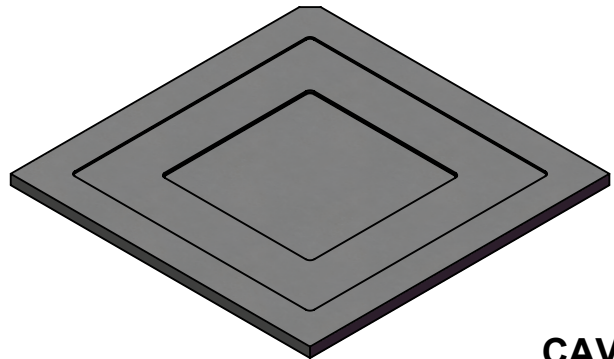
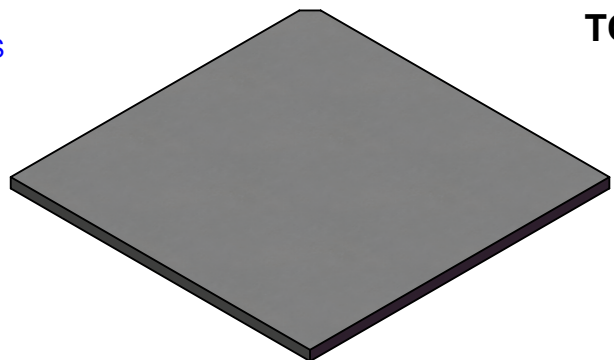
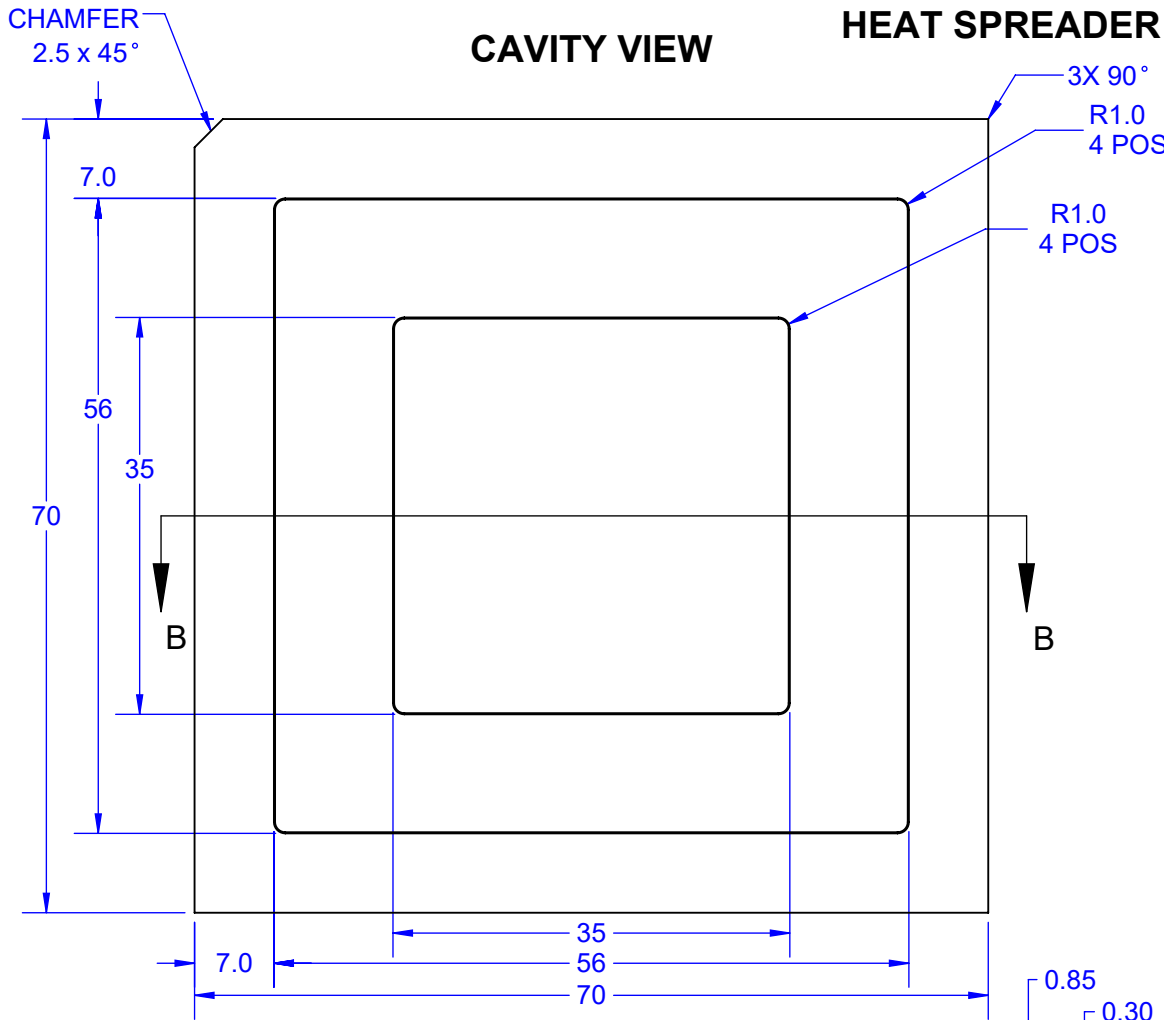

DETAIL C
SCALE 4 : 1

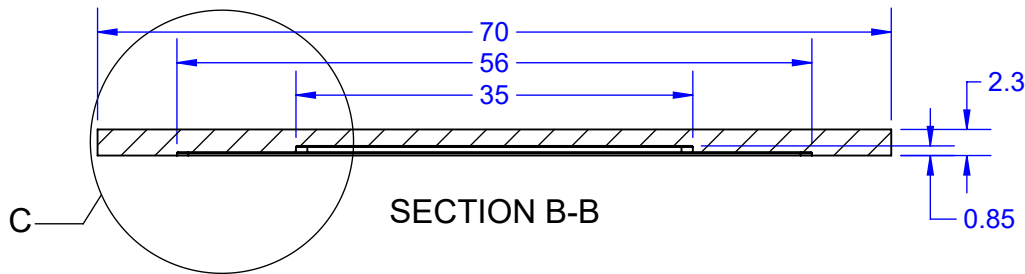
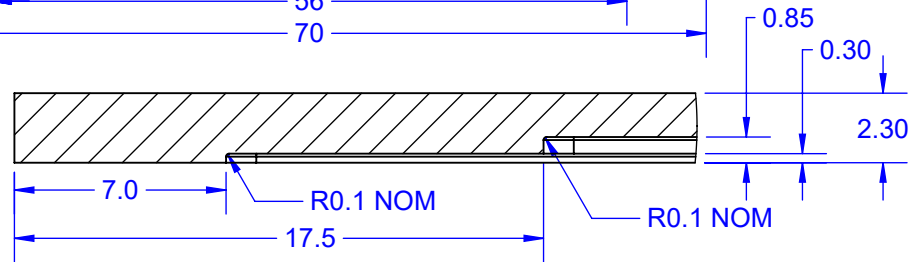

- Notes: (Unless Otherwise Specified).
- 1) DIMENSIONS: MM
 - 2) MATERIAL: COPPER C110 HALF-HARD
 - 3) PLATING: ELECTROLESS NICKEL
 - a. PER MIL-C-26074E
 - b. NICKEL (Ni) 0.0002 ~ 0.0004-INCH
 - c. MID-PHOSPHOROUS
 - d. COPPER (Cu) STRIKE

APPROVALS	DATE	TopLine®			
DRAWN T. Au	2/12/2023				
ENG M. Hart	2/12/2023	TITLE F-CAP70A FLAT CAVITY HEAT SPREADER			
MFG		SCALE	SIZE	DRAWING NO.	REV
QA		3:2	A	270790	A
CUST		DO NOT SCALE DRAWING			SHEET 4 OF 6
REVISED					

MODEL

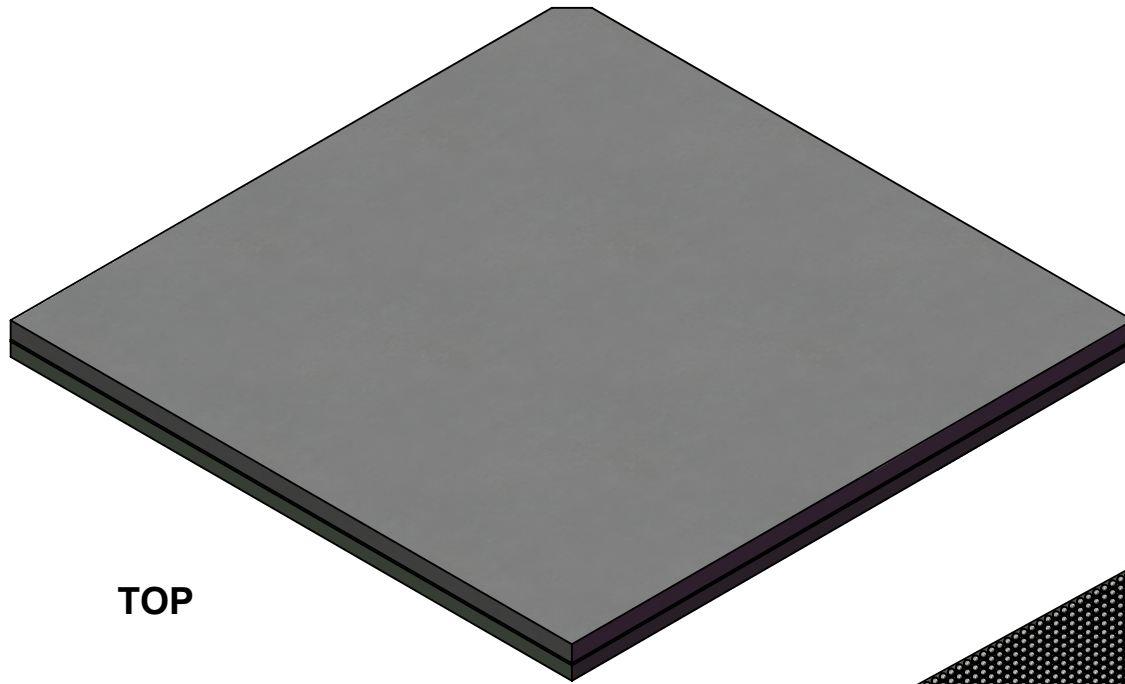

TOP

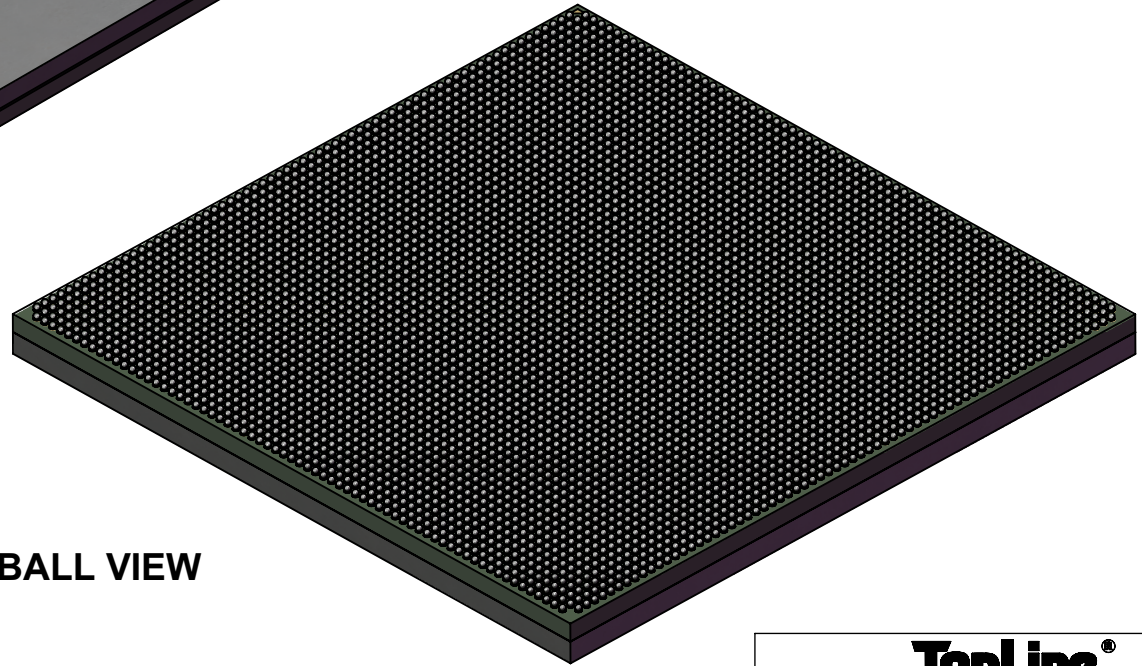

BALL VIEW

TopLine[®]

TITLE FBGA4757T1.0C-DC698D
DAISY CHAIN DUMMY

SCALE 3:2	SIZE A	DRAWING NO. 516985	REV A
--------------	-----------	-----------------------	----------

DO NOT SCALE DRAWING

SHEET 5 OF 6

BOTTOM SOLDER MASK (RIGHT READING)

69 67 65 63 61 59 57 55 53 51 49 47 45 43 41 39 37 35 33 31 29 27 25 23 21 19 17 15 13 11 9 7 5 3 1
68 66 64 62 60 58 56 54 52 50 48 46 44 42 40 38 36 34 32 30 28 26 24 22 20 18 16 14 12 10 8 6 4 2

A
C
E
G
J
L
N
R
U
W
AA
AC
AE
AG
AJ
AL
AN
AR
AU
AW
BA
BC
BE
BG
BJ
BL
BN
BR
BU
BW
CA
CC
CE
CG
CJ

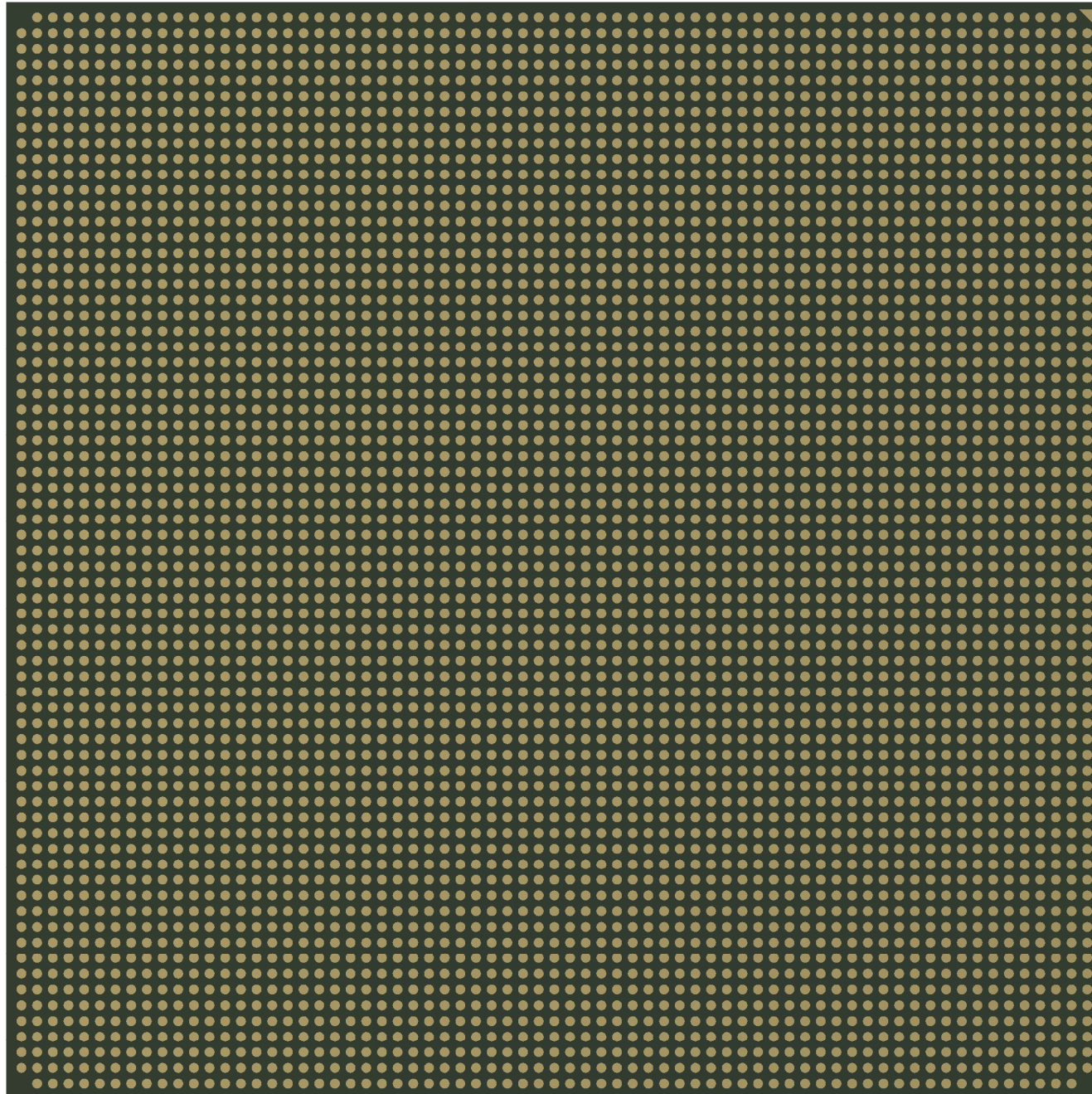

TopLine®			
TITLE		FBGA4757T1.0C-DC698D DAISY CHAIN DUMMY	
SCALE	SIZE	DRAWING NO.	REV
2.5:1	A	516985	A
DO NOT SCALE DRAWING			SHEET 6 OF 6