

STYLE FS
SCREW HOLE
OPTIONAL

TOP

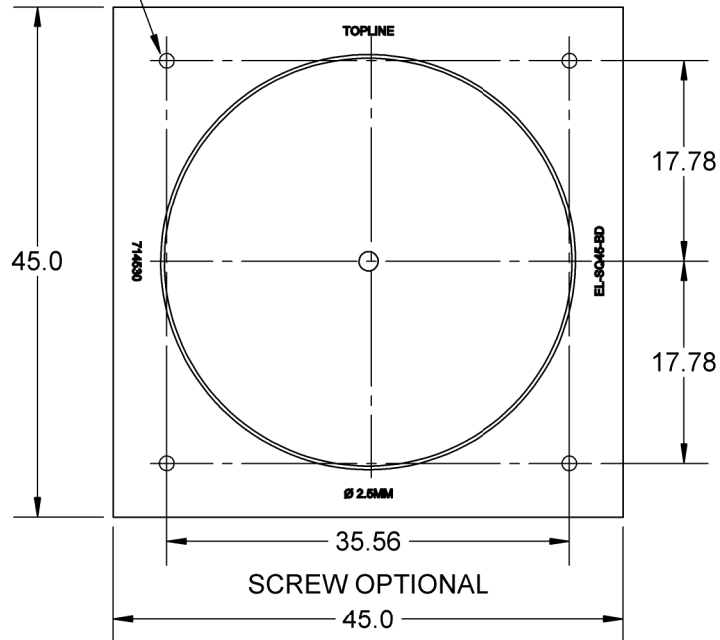

SIDE

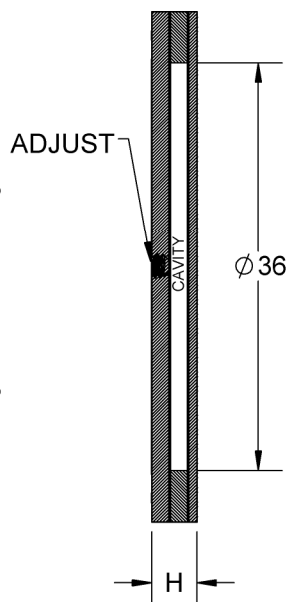

**BOTTOM
(NOTE 2)**

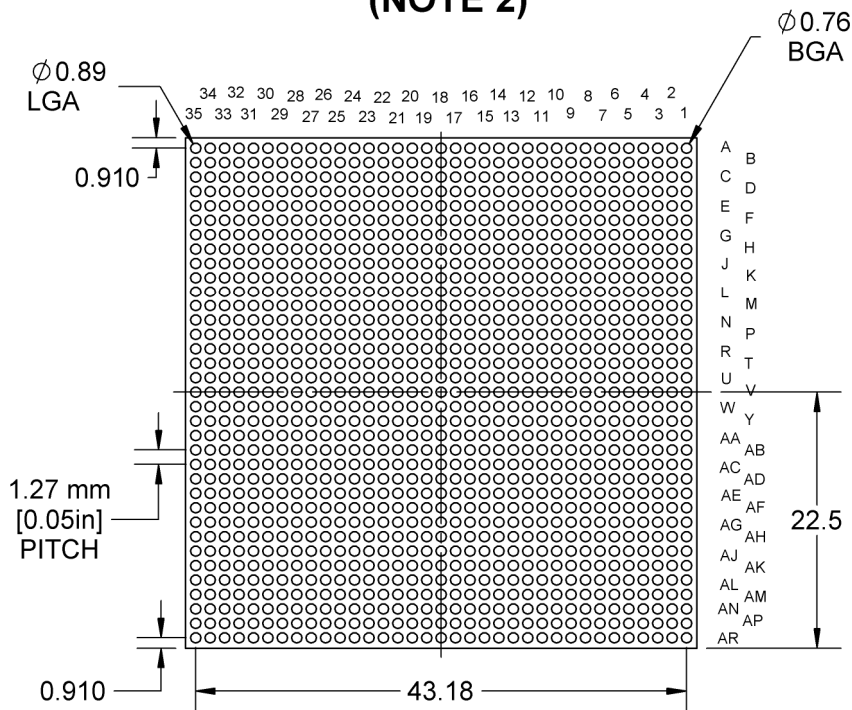

DIMENSION AND WEIGHT (MASS) TABLE

H HEIGHT ±0.5 mm	PCB MASS	TUNGSTEN BALLS IN CAVITY				Total PID MASS	SCREW ADJUST	SCREW HEX HEAD
		Ø DIA	Per Ball	QTY	Mass			
4.0mm	130g	1.5mm	0.031g	425~475	13g	27g	2-56	0.035
4.5mm	170g	2.0mm	0.073g	230~260	17g	32g	4-40	0.050
5.0mm	180g	2.3mm	0.102g	177~200	18g	33g	6-32	1/16
7.5mm	210g	2.5mm	0.143	150~166	21g	47g	6-32	1/16

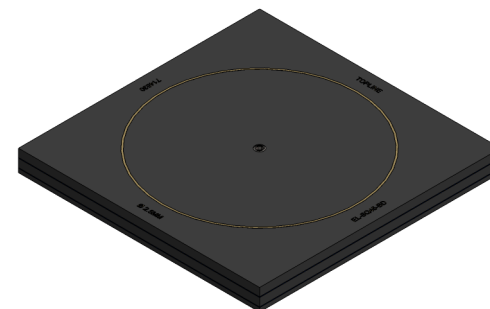

MODEL

U.S PATENT US 9521753 B1
OTHER PATENTS PENDING

NOTES: (Unless Otherwise Specified).

1) DIMENSIONS INCH (min)

NOTES 2 MOUNTING STYLE (Replace N)
1= LGA (FL) 4= BGA SAC305 (FB)
2= SCREW (FS) 5= BGA SnPb (FP)
3= ADHESIVE (FA) 9= CUSTOM

APPLICATION NOTES:

Contact TopLine for help to select
the best PID for your application.

APPROVALS	DATE				
DRAWN T. Au	12/25/2017				
ENG M. Hart	12/25/2017	SCALE 3:2 SIZE A DRAWING NO. 704530 REV A			
MFG					
QA					
CUST					
REVISED					

**MODELS
ATTACHMENT VARIATIONS**

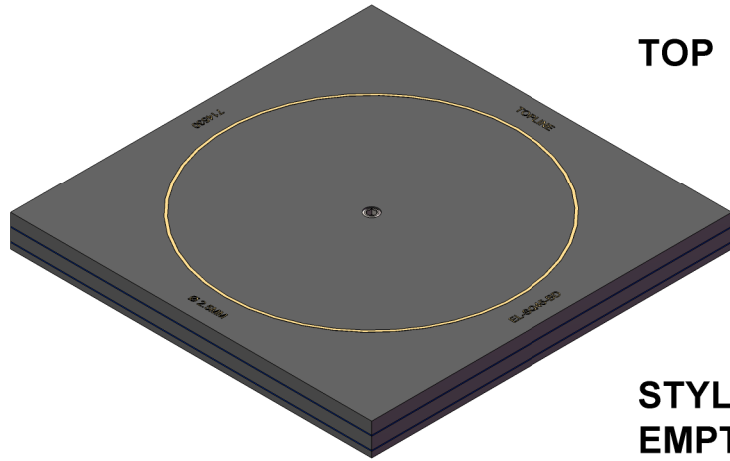

TOP

**STYLE EL
EMPTY**

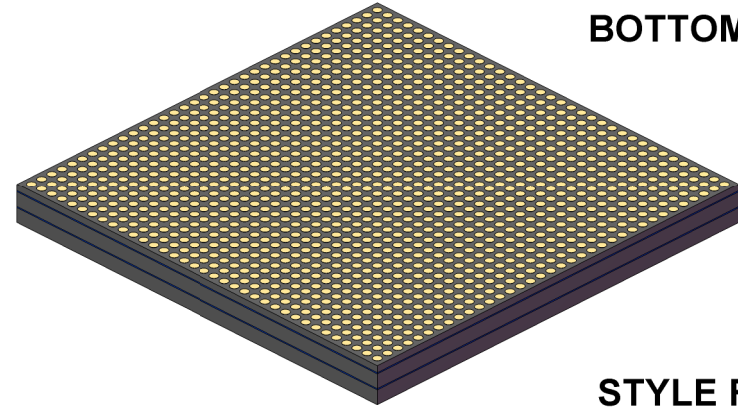

BOTTOM

**STYLE FL
LGA PADS**

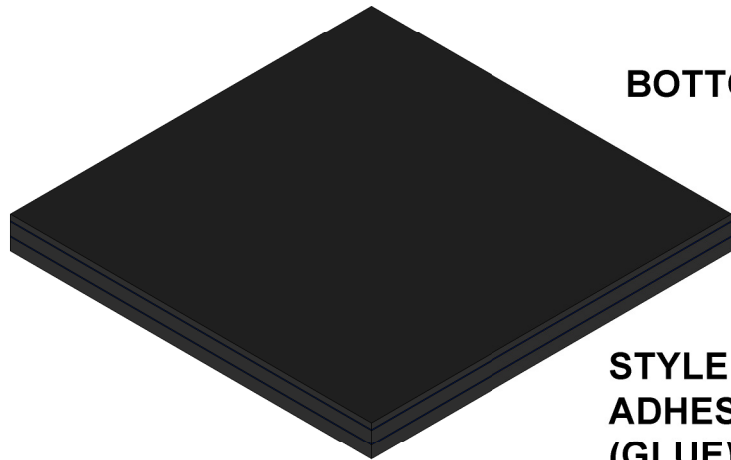

BOTTON

**STYLE FA
ADHESIVE
(GLUE)**

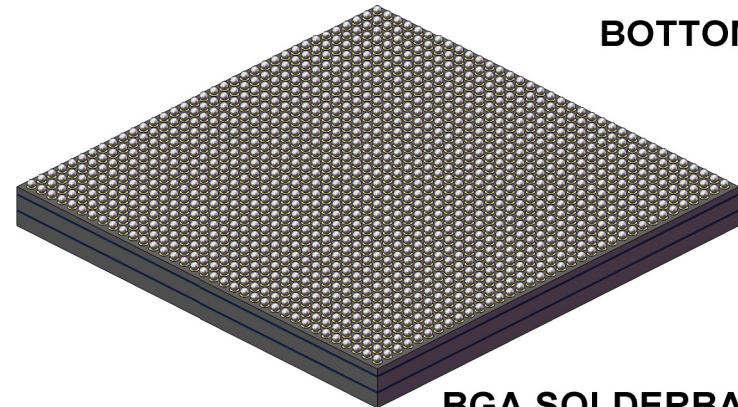

BOTTOM

**BGA SOLDERBALL
STYLE FB = SAC305 RoHS
STYLE FP = SnPb**

TopLine®

TITLE EL-SQ45-BD
PID VIBRATION DAMPER

SCALE 3:2	SIZE A	DRAWING NO. 704530	REV A
--------------	-----------	-----------------------	----------

DO NOT SCALE DRAWING

SHEET 2 OF 3

PART NUMBER SYSTEM

<u>F</u>	<u>A</u>	<u>21</u>	<u>SQ</u>	<u>45x</u>	<u>7.5</u>	<u>A</u>
Series	Mounting on PCB	Tungsten Payload Grams (Mins.)	Exterior Shape	X/Y Size	Height	Version/Option
<p>Filled</p> <p>F = FR4 Case A = Al Case</p> <p>Empty</p> <p>E = FR4 Case L = Al Case</p>	<p>Mounting Style</p> <p>A = Adhesive</p> <p>L = LGA NiAu Solderable Bottom Terminal</p> <p>B = BGA SAC Solder Ball</p> <p>P = BGA SnPb Solder Ball</p> <p>S = Screw Fastener</p>	<p>Code • Grams</p> <p>13 = 13.0gm 17 = 17.0gm 18 = 18.0gm 21 = 21.0gm</p> <p>Other Mass Available</p>	<p>Code • Shape</p> <p>SQ = Square R = Rectangle C = Cylindrical T = Toroid Z = Custom</p>	<p>Code Size</p> <p>45x = 45mm SQ</p> <p>Other Sizes Available</p>	<p>Code Height</p> <p>4.0 = 4.0mm 4.5 = 4.5mm 5.0 = 5.0mm 7.5 = 7.5mm</p> <p>Other Sizes Available</p>	<p>Code Version</p> <p>A Standard</p> <p>Other Version Available</p>

ORDER NUMBER

<u>1</u>	<u>1</u>	<u>021</u>	<u>1</u>
DESCRIPTION	Mount Style	Mass (gm) 9 = Decimal	Option Code
<p>Code • Description</p> <p>1 = Filled PID 5 = Eng Dev Kit 7 = Empty Pkg</p>	<p>Code • Description</p> <p>1 = LGA 2 = Screw 3 = Adhesive 4 = BGA SAC305 5 = BGA Sn63/Pb37 9 = Custom</p>	<p>Code • MASS</p> <p>013 = 13.0gm 017 = 17.0 gm 018 = 18.0 gm 021 = 21.0 gm</p> <p>Blank = Empty</p>	<p>Code Option</p> <p>1 = Version A 2 = Version B 3 = Version C ... 9 = Version J</p>

TopLine®			
TITLE EL-SQ45-BD PID VIBRATION DAMPER			
SCALE NONE	SIZE A	DRAWING NO. 704530	REV A
DO NOT SCALE DRAWING			SHEET 3 OF 3