

DIMENSION AND WEIGHT (MASS) TABLE								
H HEIGHT MAX	PCB MASS NOM	TUNGSTEN BALLS IN CAVITY				Total PID MASS	SCREW ADJUST	SCREW HEX HEAD
		Ø DIA	Per Ball	QTY	MASS			
4.5mm	20g	2.0mm	0.073g	27~29	2.0g	~4.5g	4-40	0.05"

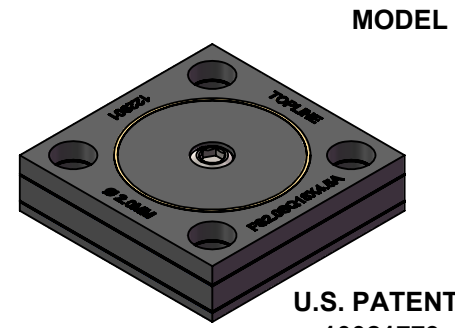

**U.S. PATENTS 10041558,  
10021779, 10704639,  
10704639, D842351**

NOTES: (Unless Otherwise Specified).  
 1. DIMENSIONS mm.  
 2. MOUNTING SCREW M3 or 4-40.  
 3. ALTERNATIVE MOUNTING ADHESIVE (GLUE).

APPROVALS	DATE	<b>TopLine®</b>			
DRAWN T. Au	8/18/2022				
ENG M. Hart	8/18/2022	TITLE FS2.0SQ18X4.5A PID VIBRATION DAMPER			
MFG		SCALE 4:1	SIZE A	DRAWING NO. 122901	REV A
QA		DO NOT SCALE DRAWING			SHEET 1 OF 3
CUST					
REVISED					

# MODEL

TOP

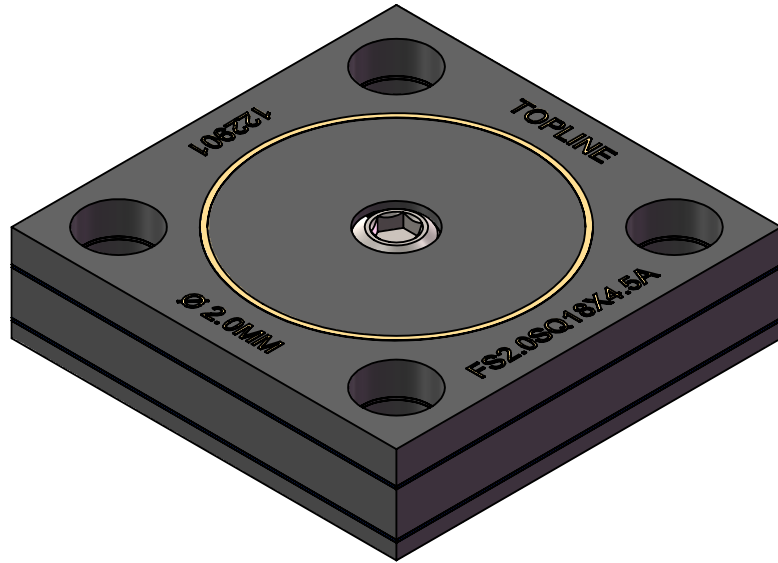

BOTTOM

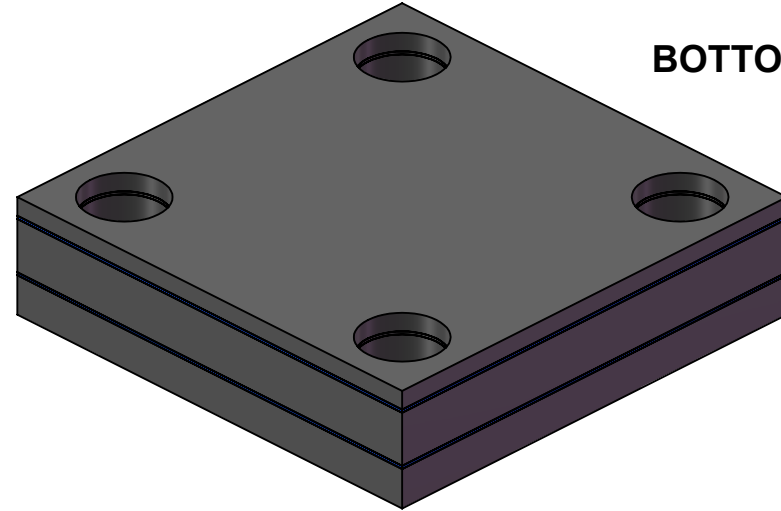

NOTES:  
1. CONTACT TOPLINE FOR OTHER MOUNTING OPTIONS.

<b>TopLine®</b>			
TITLE      FS2.0SQ18X4.5A PID VIBRATION DAMPER			
SCALE 4:1	SIZE A	DRAWING NO. 122901	REV A
DO NOT SCALE DRAWING			SHEET 2 OF 3

## Part Number System

Part Number System						
<u>F</u>	<u>S</u>	<u>2.0</u>	<u>SQ</u>	<u>18x</u>	<u>4.5</u>	<u>A</u>
Series	Mounting on PCB	Tungsten Payload Grams	Exterior Shape	X/Y Size	Height	Version/Option
<b><u>Filled</u></b>  F = FR4 Single Layer	<b><u>Mounting Style</u></b>  S = SCREW MOUNT  A = ADHESIVE GLUE	<b><u>Code Grams</u></b>  2.0 = 2.0gm  Other Mass Available	<b><u>Code Shape</u></b>  SQ Square R Rectangle C Cylindrical T Toroid Z Custom	<b><u>Code Size</u></b>  18 = 18mm SQ  Other Sizes Available	<b><u>Code Height</u></b>  4.5 = 4.5mm  Other Sizes Available	<b><u>Code Version</u></b>  A = Version A  Other Version Available
<b><u>Empty</u></b>  E = FR4 Case						

## Order Number

Order Number			
<u>1</u>	<u>2</u>	<u>290</u>	<u>1</u>
DESCRIPTION	Mount Style	Mass (gm) 9 = Decimal	Option Code
<b><u>Code Description</u></b>  1 = Filled PID	<b><u>Code Description</u></b>  2 = Screw 3 = Adhesive 9 = Custom 0 = Master DWG	<b><u>Code MASS</u></b>  290 = 2.9 gm	<b><u>Code Option</u></b>  1 = Version A

**TopLine®**

TITLE FS2.0SQ18X4.5A  
PID VIBRATION DAMPER

SCALE NONE	SIZE A	DRAWING NO. 122901	REV A
---------------	-----------	-----------------------	----------

DO NOT SCALE DRAWING

SHEET 3 OF 3