

**DETAIL A  
SCALE 25 : 1**

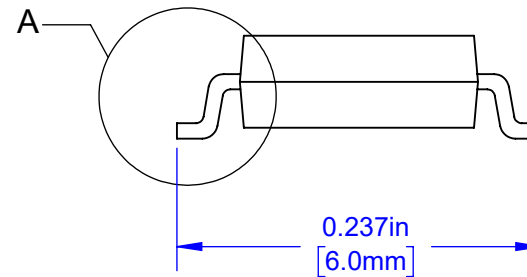
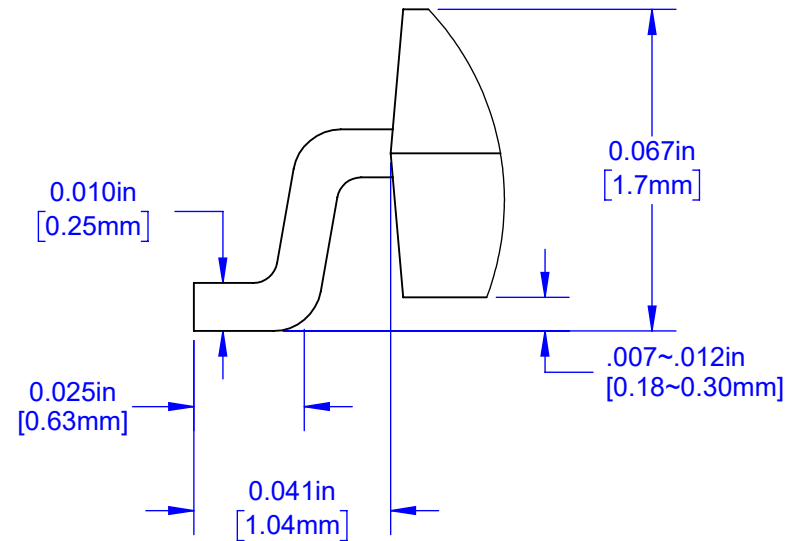

Notes: (Unless Otherwise Specified)

- 1) DIMENSION IN INCH (mm).
- 2) SEE JUMPER DIAGRAMS (PAGE 2).
- 3) SEE PART NUMBER CONFIGURATION (PAGE 4).
- 4) RECOMMENDED PC BOARD LAYOUT PATTERN (PAGE 7).

APPROVALS	DATE	<b>TopLine®</b>			
DRAWN T. Au	2/16/2021				
ENG M. Hart	2/16/2021	TITLE SO16 JUMPER SOIC 3.9mm PACKAGE			
MFG		SCALE 8:1	SIZE A	DRAWING NO. 121609	REV A
QA					
CUST		DO NOT SCALE DRAWING			SHEET 1 OF 8
REVISED					

# INTERNAL WIRING CIRCUIT (JUMPER) DAISY CHAIN PART NUMBER SUFFIX TOP VIEW

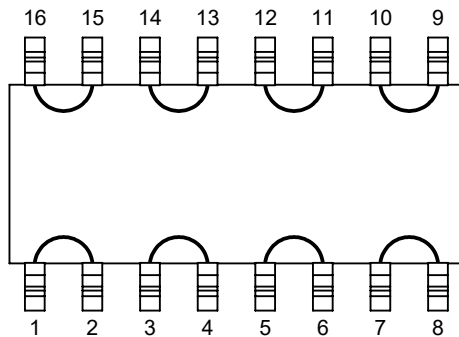

**DE**  
DAISY CHAIN EVEN

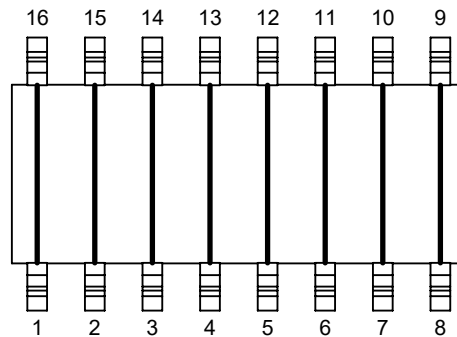

**DC1616**  
JUMPER

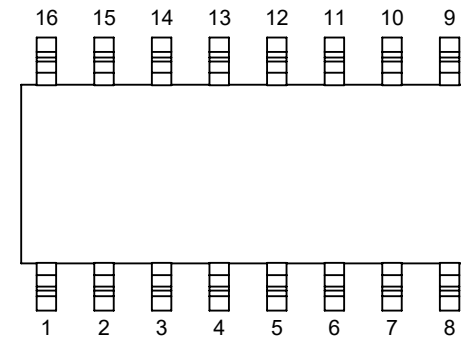

**ISO**  
ISOLATED CIRCUIT  
NO INTERNAL  
CONNECTIONS

## MODEL

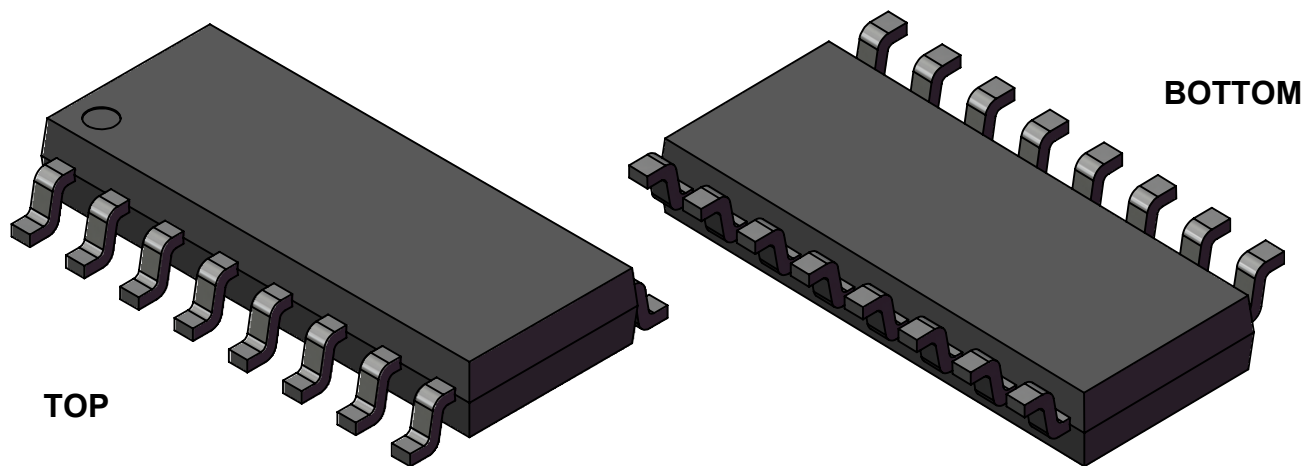

<b>TopLine®</b>			
TITLE      SO16 JUMPER SOIC 3.9mm PACKAGE			
SCALE	SIZE	DRAWING NO.	REV
8:1	A	121609	A
DO NOT SCALE DRAWING			SHEET 2 OF 8

**SCHEMATIC EQUIVALENT INTERNAL CIRCUIT (DC1616)**

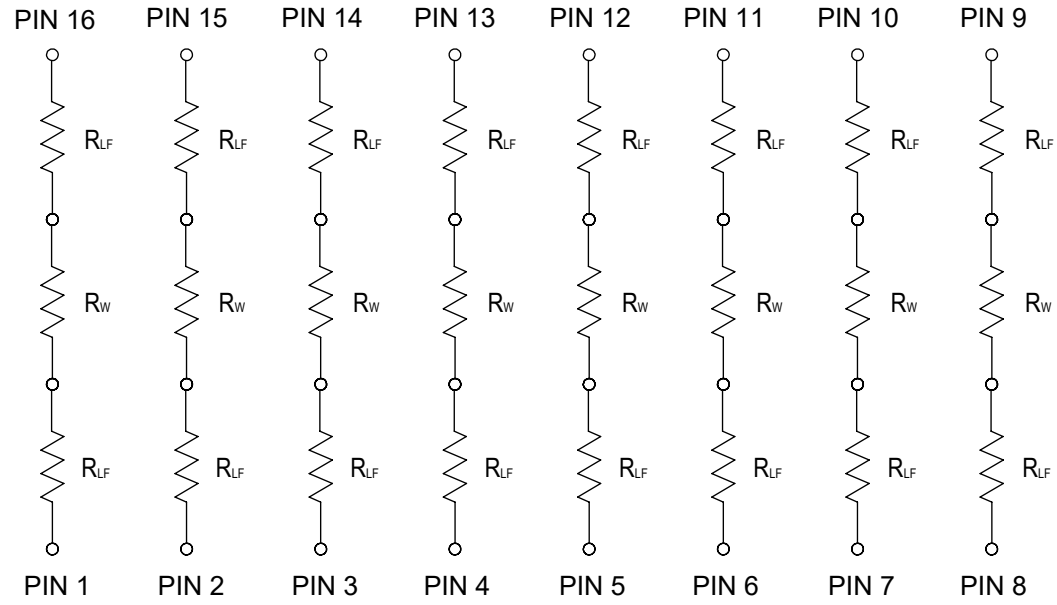

$R_W$  = GOLD WIRE-BOND.

$R_{LF}$  = LEAD FRAME.

**ELECTRICAL RESISTANCE MILIOHM (DC) MAX**

CIRCUIT	PIN TO PIN
1 ~ 16	50 mΩ
2 ~ 15	50 mΩ
3 ~ 14	50 mΩ
4 ~ 13	50 mΩ
5 ~ 12	50 mΩ
6 ~ 11	50 mΩ
7 ~ 10	50 mΩ
8 ~ 9	50 mΩ

**TEMPERATURE RATING**

JUNCTION TEMP $T_J$	150°C
STORAGE TEMP $T_{stg}$	-65°C TO 150°C
OPERATING TEMP	-65°C TO 150°C
PEAK REFLOW TEMP $T_{reflow}$ 10 SECONDS	260°C

**MAXIMUM ELECTRICAL (DC) RATING PER PIN**

WORKING VOLTAGE	100 V
CURRENT RATING	100mA
POWER @ 25°C	350 mW

**THERMAL RESISTANCE**

JUNCTION TO AMBIENT ( $T_a=25^\circ$ ) $R_{th(j-a)}$	350K/W
---	--------

**TopLine®**

TITLE			
SO16 JUMPER SOIC 3.9mm PACKAGE			
SCALE	SIZE	DRAWING NO.	REV
NONE	A	121609	A
DO NOT SCALE DRAWING			SHEET 3 OF 8

PART NUMBERING SYSTEM

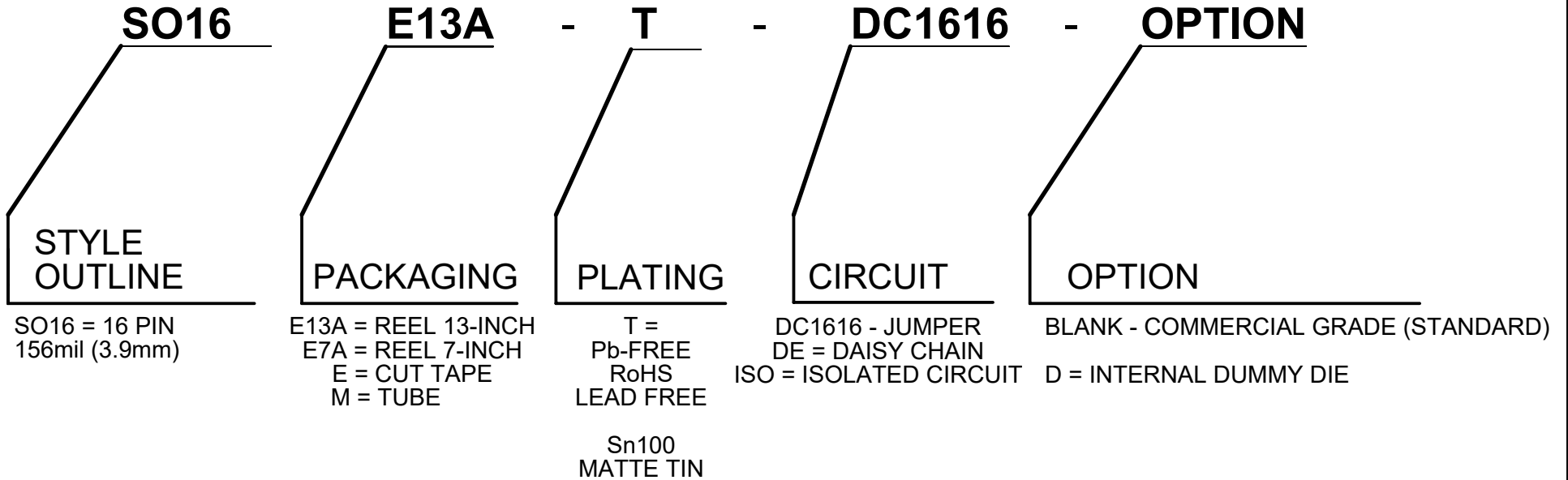

PART NUMBER	SHORTED PINS	NOTES	RoHS Pb-FREE	MSL LEVEL
SO16E13A-T-DC1616	1~16, 2~15, 3~14, 4~13, 5~12, 6~11, 7~10, 8~9.	8-WIRES	YES	3
SO16E13A-T-DE	1~2, 3~4, 5~6, 7~8, 9~10, 11~12, 13~14, 15~16	8-WIRES	YES	3
SO16E13A-T	N/A	DUMMY	YES	3
SO16E13A-T-ISO	NONE	FULLY ISOLATED	YES	3

**TopLine®**

TITLE SO16 JUMPER  
SOIC 3.9mm PACKAGE

SCALE NONE	SIZE A	DRAWING NO. 121609	REV A
DO NOT SCALE DRAWING			SHEET 4 OF 8

**MATERIALS CONTENT DECLARATION FORM  
SO16 PACKAGE**

Component	Material	Material		Substance	CAS No.	Substance		
		(%wt)	(mg)			(%wt)	(mg)	(ppm)
Die	Doped Si	2.66%	3.86	Si	7440-21-3	2.66%	3.86	26,621
Bond Wire	Gold	0.28%	0.4	Au	7440-57-5	0.28%	0.4	2,759
Leadframe	Copper	31.38%	45.5	Cu	7440-50-8	31.38%	45.5	313,793
Die Attach	Epoxy	0.3%	0.44	Ag	7440-22-4	0.24%	0.35	2,414
				Epoxy Resin	Proprietary	0.06%	0.09	621
Encapsulation	EMC	63.79%	92.5	Silica (fused)	60676-86-0	44.9%	65.1	448,966
				Epoxy Resin	Proprietary	15.86%	23.0	158,921
				Sb <sub>2</sub> O <sub>3</sub>	1309-64-4	1.24%	1.8	12,414
				TBBA	79-94-7	1.52%	2.2	15,172
				Carbon	1333-86-4	0.28%	0.4	2,759
Plating	Matte Tin	1.59%	2.3	Sn	7440-31-5	1.59%	2.3	15,862

Package Weight (mg): 145

% Total: 100

This Pb-Free package is compliant to RoHS and meet the Directive 2002/95/ED (RoHS) requirement as well as (REACH) Eu Directive 1999/45/EC and 1907/2006/EC

<b>TopLine®</b>			
TITLE SO16 JUMPER SOIC 3.9mm PACKAGE			
SCALE NONE	SIZE A	DRAWING NO. 121609	REV A
DO NOT SCALE DRAWING			SHEET 5 OF 8

# TAPE SPECIFICATION SO16 SURFACE MOUNT DEVICE

## TAPE DIMENSIONS

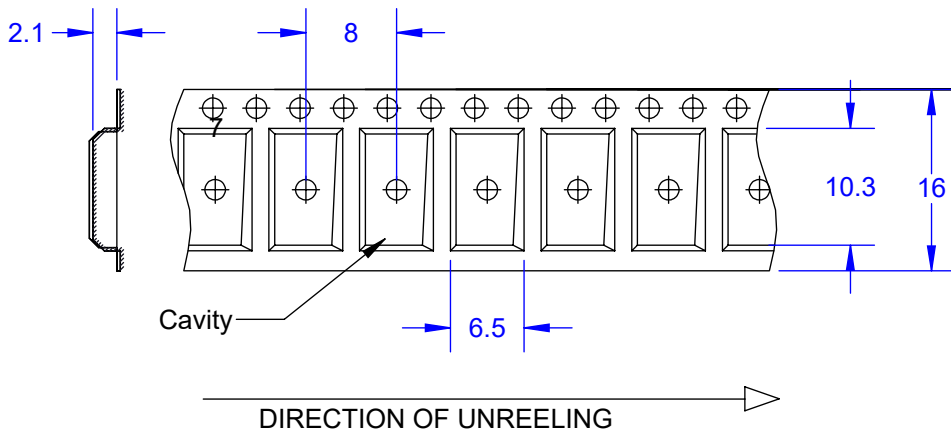

## PACKAGE REEL

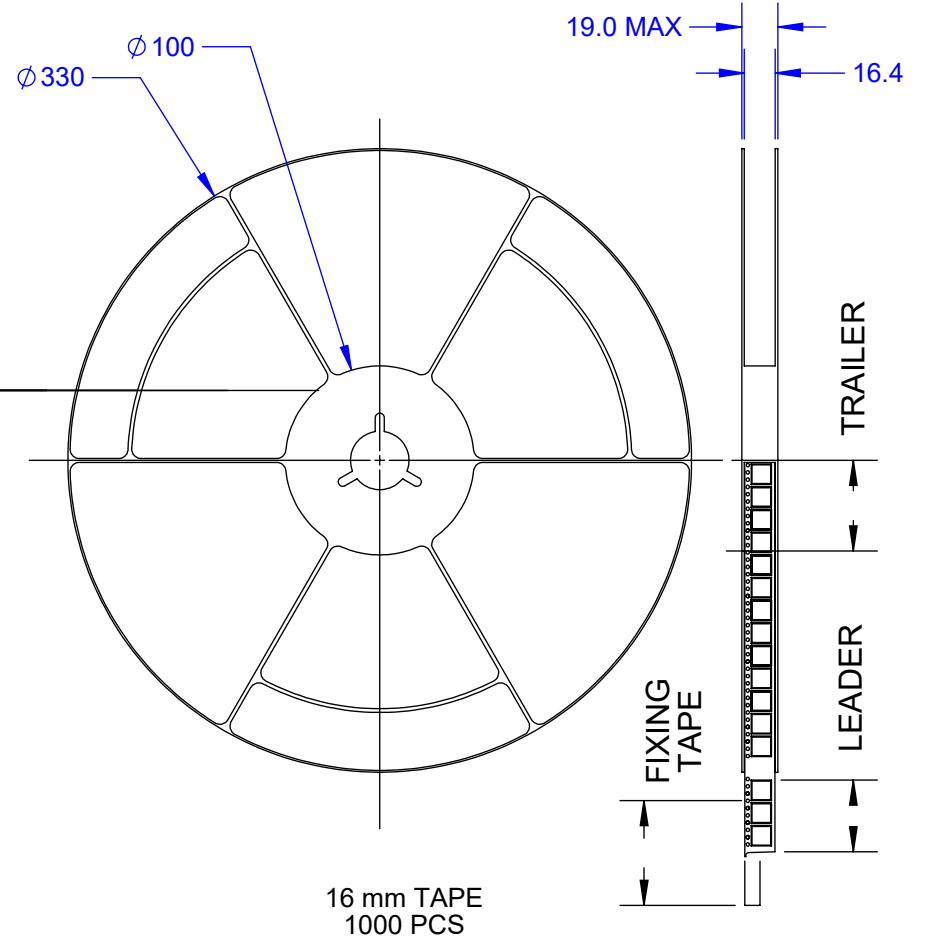

ALL DIMENSIONS IN mm

<b>TopLine®</b>			
TITLE		SO16 JUMPER SOIC 3.9mm PACKAGE	
SCALE	SIZE	DRAWING NO.	REV
NONE	A	121609	A
DO NOT SCALE DRAWING			SHEET 6 OF 8

# PC BOARD LAND PATTERN

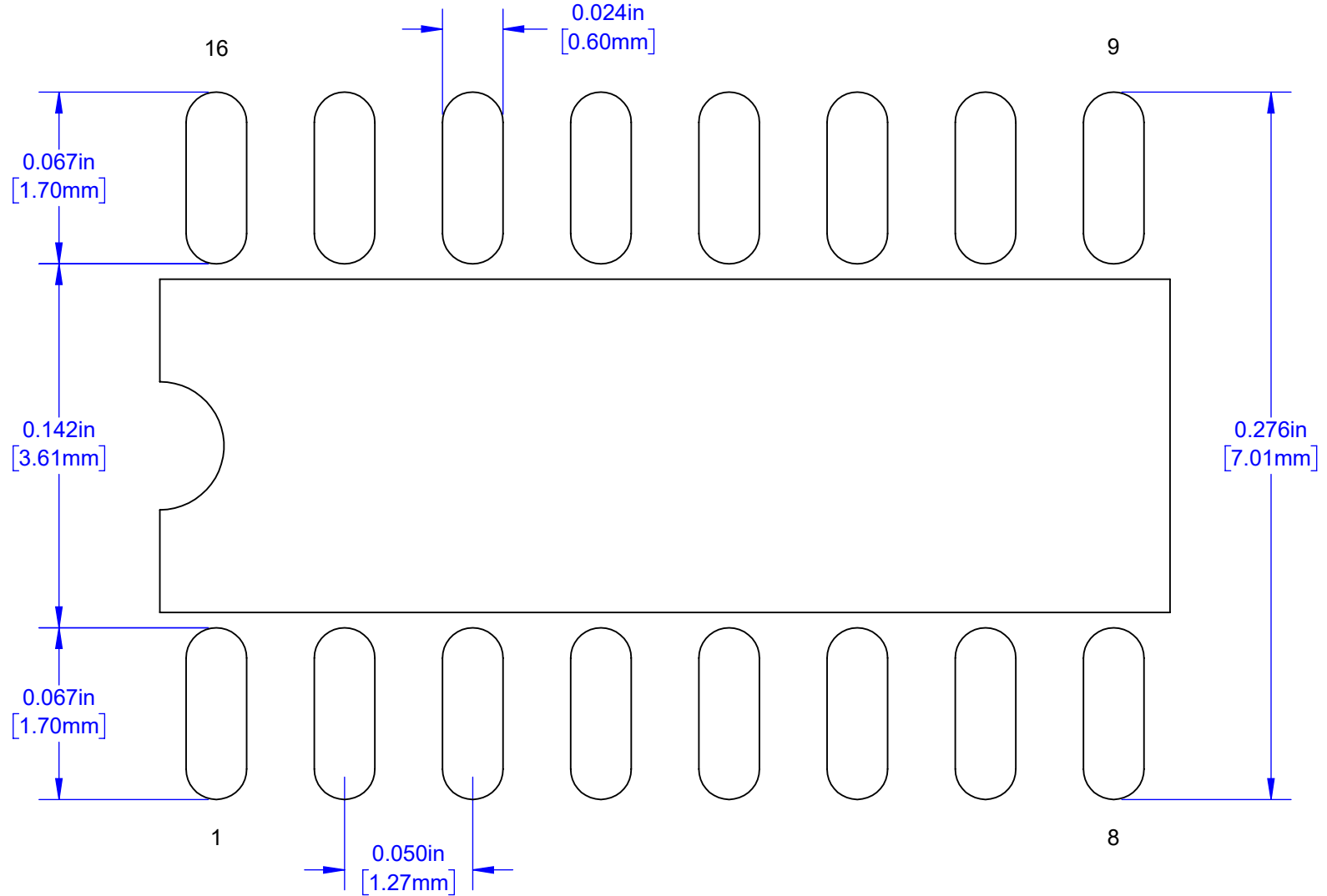

Notes: (Unless Otherwise Specified)

- 1) DIMENSIONS ARE IN INCH (mm).
- 2) PCB BOARD DIMENSIONS ARE PRESENTED ONLY AS A GUIDELINE.
- 3) DESIGNERS SHOULD USE THEIR OWN EXPERIENCE WHEN DESIGNING PCB.

**TopLine®**

TITLE			
SO16 JUMPER SOIC 3.9mm PACKAGE			
SCALE	SIZE	DRAWING NO.	REV
16:1	A	121609	A
DO NOT SCALE DRAWING			SHEET 7 OF 8

# LEAD FREE REFLOW PROFILE OF SMD PACKAGE

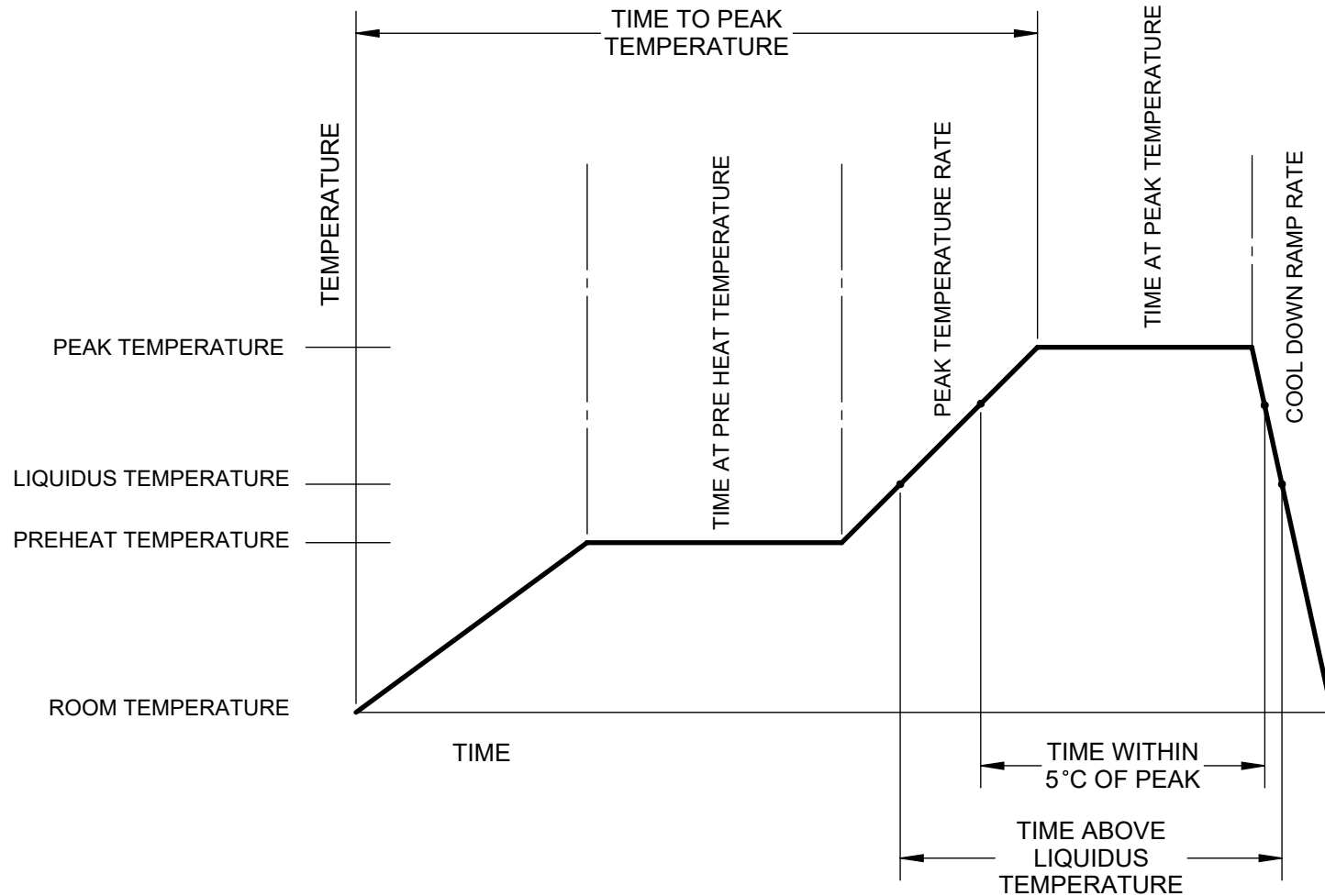

DESCRIPTION	REQUIREMENT
AVERAGE PREHEAT RAMP RATE	3 °C/SECOND MAXIMUM
PREHEAT TEMPERATURE	150 °C MAXIMUM, 200 °C MAXIMUM
PREHEAT TIME	60 TO 80 SECONDS
RAMP TO PEAK	3 °C/SECOND MAXIMUM
TIME OVER LIQUIDUS (217°C)	60 TO 150 SECONDS
PEAK TEMPERATURE	260 °C +0/-5 °C
TIME WITHIN 5°C OF PEAK	20 TO 40 SECONDS
RAMP - COOL DOWN	6 °C/SECONDS MAXIMUM
TIME 25°C TO PEAK	8 MINUTES MAXIMUM

<b>TopLine®</b>			
TITLE SO16 JUMPER SOIC 3.9mm PACKAGE			
SCALE	SIZE	DRAWING NO.	REV
NONE	A	121609	A
DO NOT SCALE DRAWING			SHEET 8 OF 8