

NOTES :

1. Package dimensions conform to Jedec MO-142-DD.
2. Controlling dimensions are mm.
Dimensions in inches are shown in parentheses.
3. All dimension and tolerancing conforms to ASME Y14.5M-1994.
4. Profile tolerance zones for "D1" and "E" do not include mold protrusion. allowable mold protrusion on "E" is 0.15mm(.006") per side and on "D1" is 0.25mm(0.010") per side.

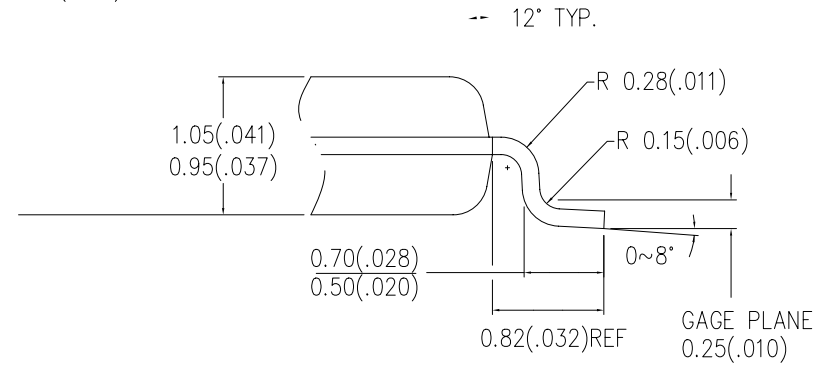

DETAIL "A"

LIST OF MATERIAL AND APPLICABLE DOCUMENTS				
SCALE: NONE	DATE: 07/19/05	DRAWN:	TITLE: TSOP TYPE-I 48 LEAD	
DIMENSIONAL UNIT: MM (INCH)	UNTOLERANCED DIMENSIONS	ENGINEER:	12.00 X 20.00 MM	
PROJECTION UNLESS SPECIFIED	FRAC: .XX .XXX .XXXX ANGLE	CHECKED:	PACKAGE OUTLINE.	
		APPROVED:	CAD NAME:	DRAWING NUMBER:
			REV. -	SHEET: 1 OF 1

PART NUMBER TABLE

ITEM	TOPLINE PART NBR	DAISY CHAIN	RoHS Pb FREE	DUMMY DIE		LEAD FRAME		PACKAGING	DWG NBR
				MILS	um	MATL	PLATING		
1	TSOP48T19.7T-DE-DA	YES	YES	125x200	4200x5080	ALLOY 42	Sn	TRAY 96	159228
2	TSOP48E13A-T-DE-DA	YES	YES	125x200	4200x5080	ALLOY 42	Sn	REEL 1000	159228
3	TSOP48T19.7T-ISO-A	NO	YES	-	-	ALLOY 42	Sn	TRAY 96	167577
4	TSOP48E13A-T-ISO-A	NO	YES	-	-	ALLOY 42	Sn	REEL 1000	167577
5	TSOP48T19.7T-DE-D	YES	YES	125x200	4200x5080	CU	Sn	TRAY 96	
6	TSOP48E13A-T-DE-D	YES	YES	125x200	4200x5080	CU	Sn	REEL 1000	
7	TSOP48T19.7T-ISO	NO	YES	-	-	CU	Sn	TRAY 96	
8	TSOP48E13A-T-ISO	NO	YES	-	-	CU	Sn	REEL 1000	

9	TSOP48T19.7-DE-D	YES	NO	125x200	4200x5080	CU	SnPb	TRAY 96	164046
10	TSOP48E13A-DE-D	YES	NO	125x200	4200x5080	CU	SnPb	REEL 1000	164046

TOLERANCE UNLESS NOTED		APPROVALS	DATE	TopLine [®]			
X.X	+/- 0.3	DRAWN J. Hines	12/4/2010				
X.XX	+/- 0.03						
X.XXX	+/- 0.003	ENG		SCALE	SIZE	DRAWING NO.	REV
ANGLES	+/- 0.5°	MFG		20:1	A		A
ALL DIMENSIONS IN		QA		DO NOT SCALE DRAWING			
<input type="checkbox"/> INCHES	<input type="checkbox"/> MILLIMETERS	CUST					
THIRD ANGLE PROJECTION		REVISED					

TSOP48 Daisy Chain

Net List	
From	To
1	2
3	4
5	6
7	8
9	10
11	12
13	14
15	16
17	18
19	20
21	22
23	24
25	26
27	28
29	30
31	32
33	34
35	36
37	38
39	40
41	42
43	44
45	46
47	48

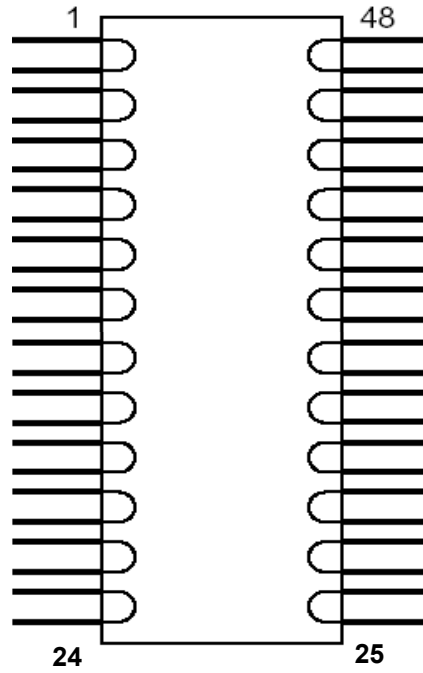

TOLERANCE UNLESS NOTED		APPROVALS	DATE	TopLine [®]			
X.X	+/- 0.3						
X.XX	+/- 0.03	DRAWN J. Hines	12/4/2010	TITLE TSOP48 DAISY CHAIN			
X.XXX	+/- 0.003						
ANGLES	+/- 0.5°	ENG		SCALE 20:1 SIZE A DRAWING NO. 159228 REV A			
ALL DIMENSIONS IN		MFG					
<input type="checkbox"/> INCHES	<input type="checkbox"/> MILLIMETERS	QA		DO NOT SCALE DRAWING			
THIRD ANGLE PROJECTION		CUST					
		REVISED					