

OUTLINE DIMENSIONS

DIE SIDE

BUMP SIDE

2 4 6 8 10 12 14 16 18 20 22 24
1 3 5 7 9 11 13 15 17 19 21 23

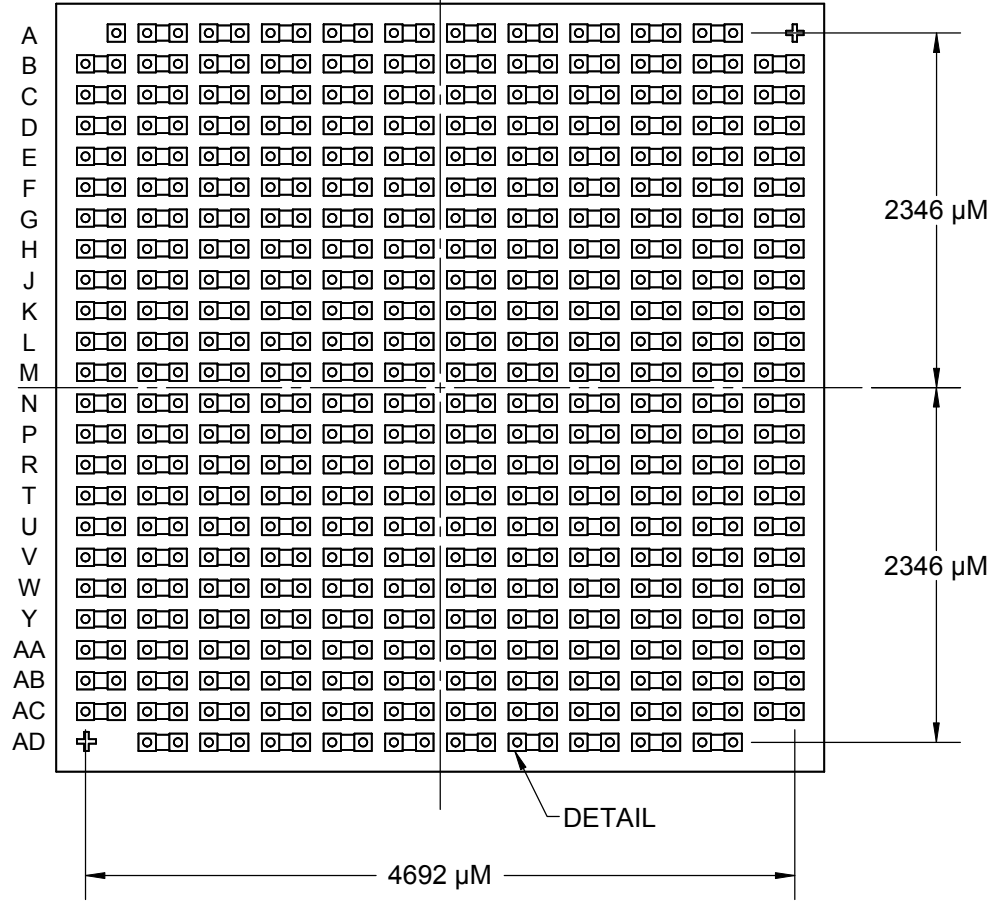
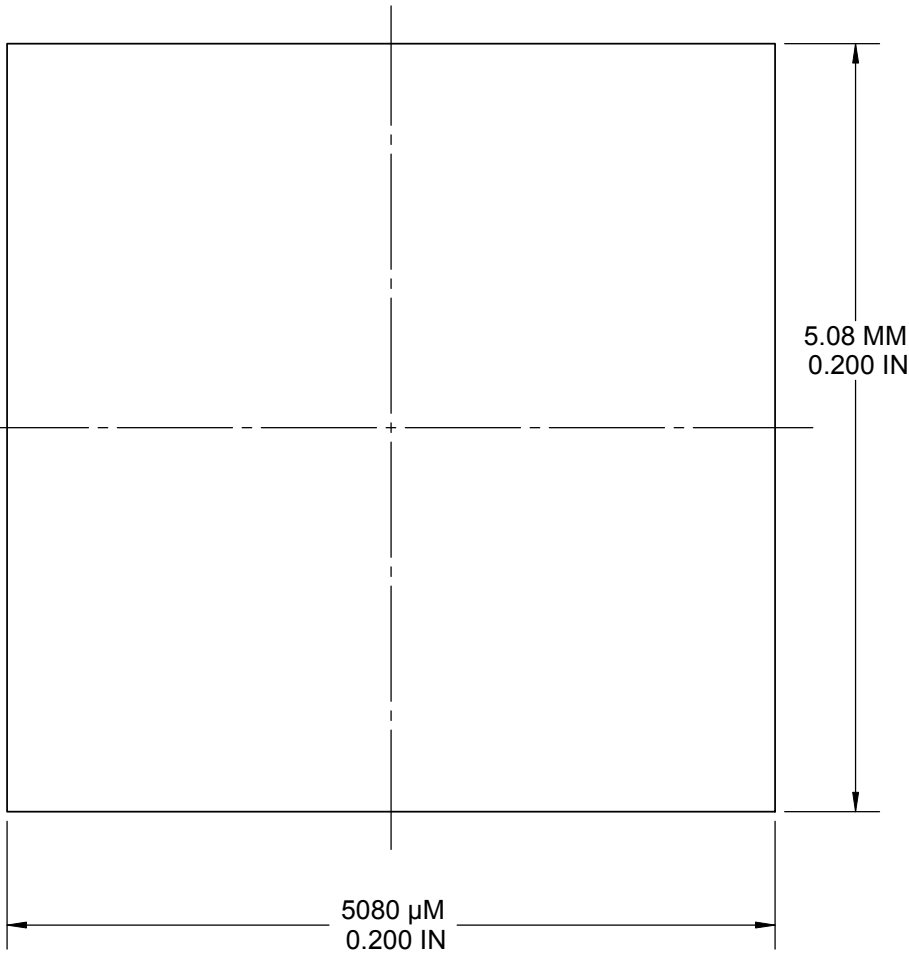

SOLDER BUMP PAD
DETAIL 1

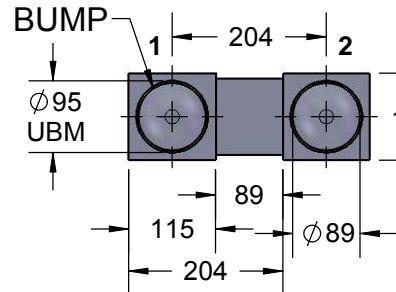

WIRE BONDING PAD
DETAIL 2

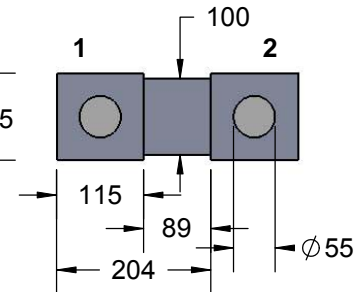

PART NUMBER TABLE				
PART NUMBER	BUMP ALLOY	Pb-Free	BUMP	DETAIL
FC569G5C204-DC	SAC - SnAgCu	YES	YES	1
FC569G5E204-DC	SnPb Eutectic	NO	YES	1
FCN569G5A204-DC	Al - BUMPLESS	YES	NO	2

TopLine

TITLE FC569-204μM PITCH
FLIP CHIP 5.08 X 5.08 MM

SCALE 20:1	SIZE A	DRAWING NO. 181923	REV A
------------	--------	--------------------	-------

DO NOT SCALE DRAWING SHEET 2 OF 13

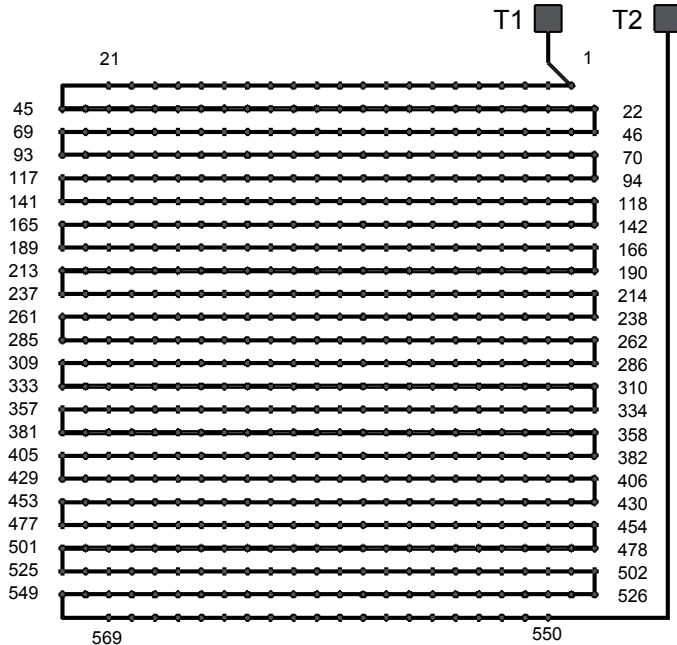
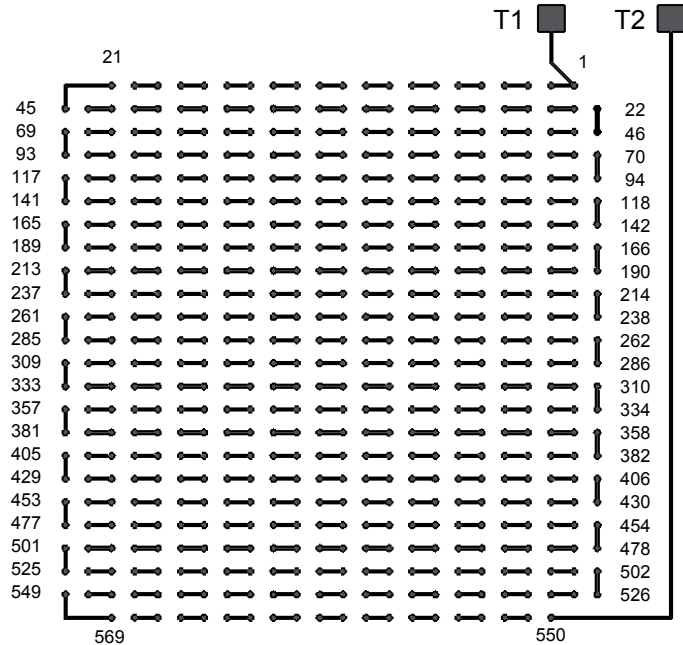
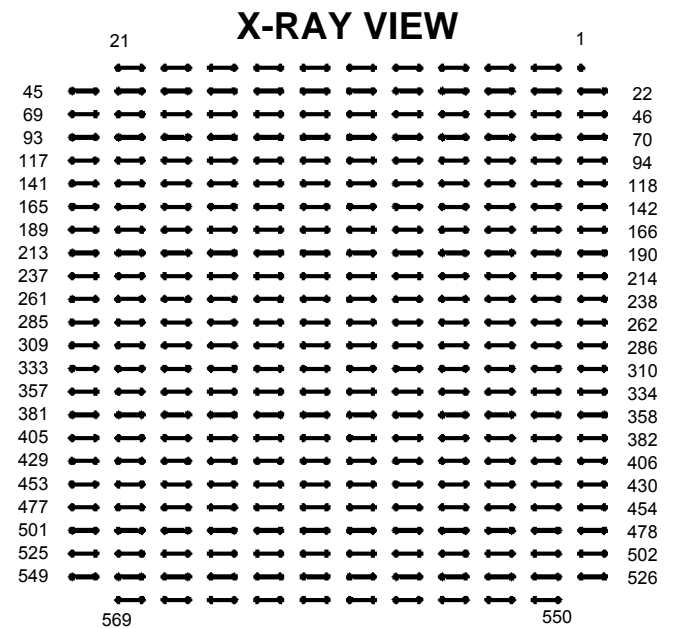
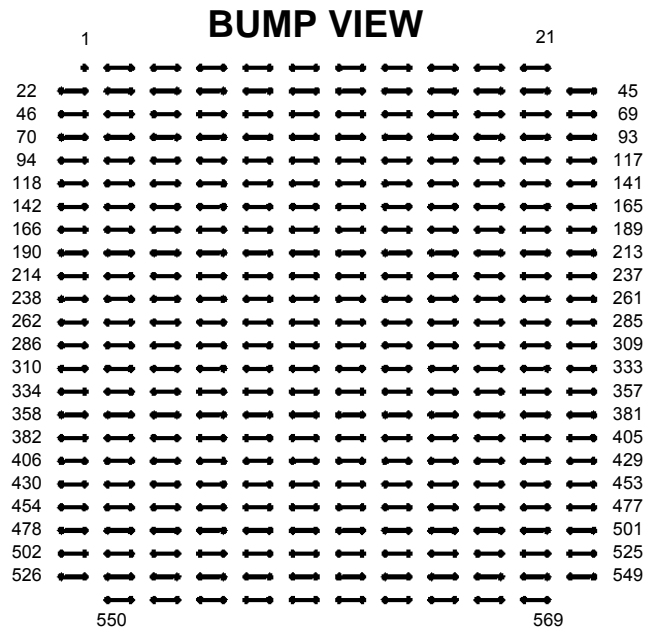

TopLine [®]			
TITLE FC569-204μM PITCH FLIP CHIP 5.08 X 5.08 MM			
SCALE 15:1	SIZE A	DRAWING NO. 181923	REV A
DO NOT SCALE DRAWING			SHEET 3 OF 13

PAD LOCATION SHOWN BUMP VIEW DIMENSION IN MICRON (μM)

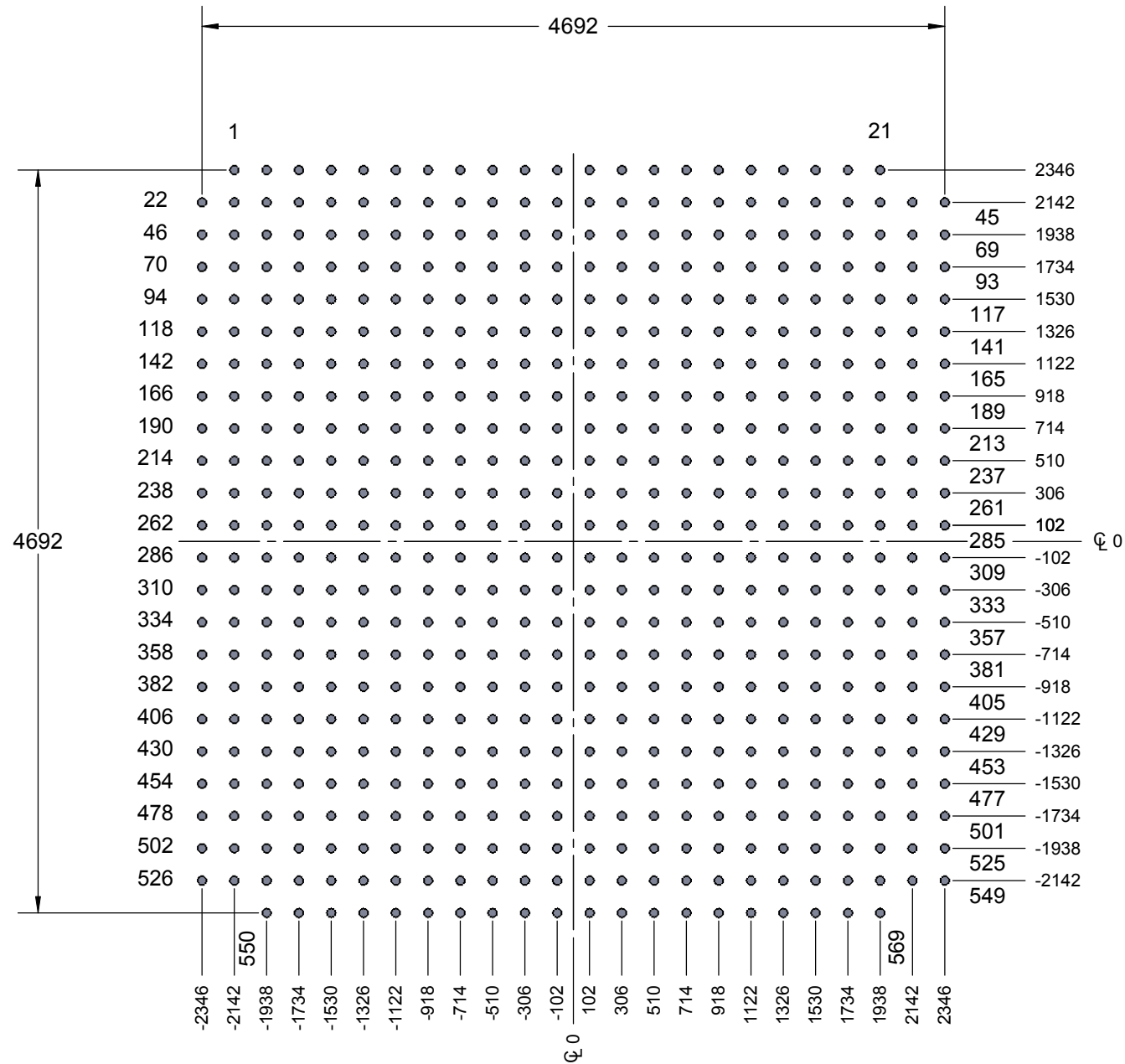

- NOTES:
 1) DIMENSIONS IN MICRONS (μM).
 2) X=0, Y=0 IS CENTER OF DIE.
 3) SEE NET LIST PAGE 6-9.

TopLine [®]			
TITLE FC569-204 μM PITCH FLIP CHIP 5.08 X 5.08 MM			
SCALE 25:1	SIZE A	DRAWING NO. 181923	REV A
DO NOT SCALE DRAWING			SHEET 4 OF 13

BONDING MAP SEE NET LIST (PAGES 6 TO 9)

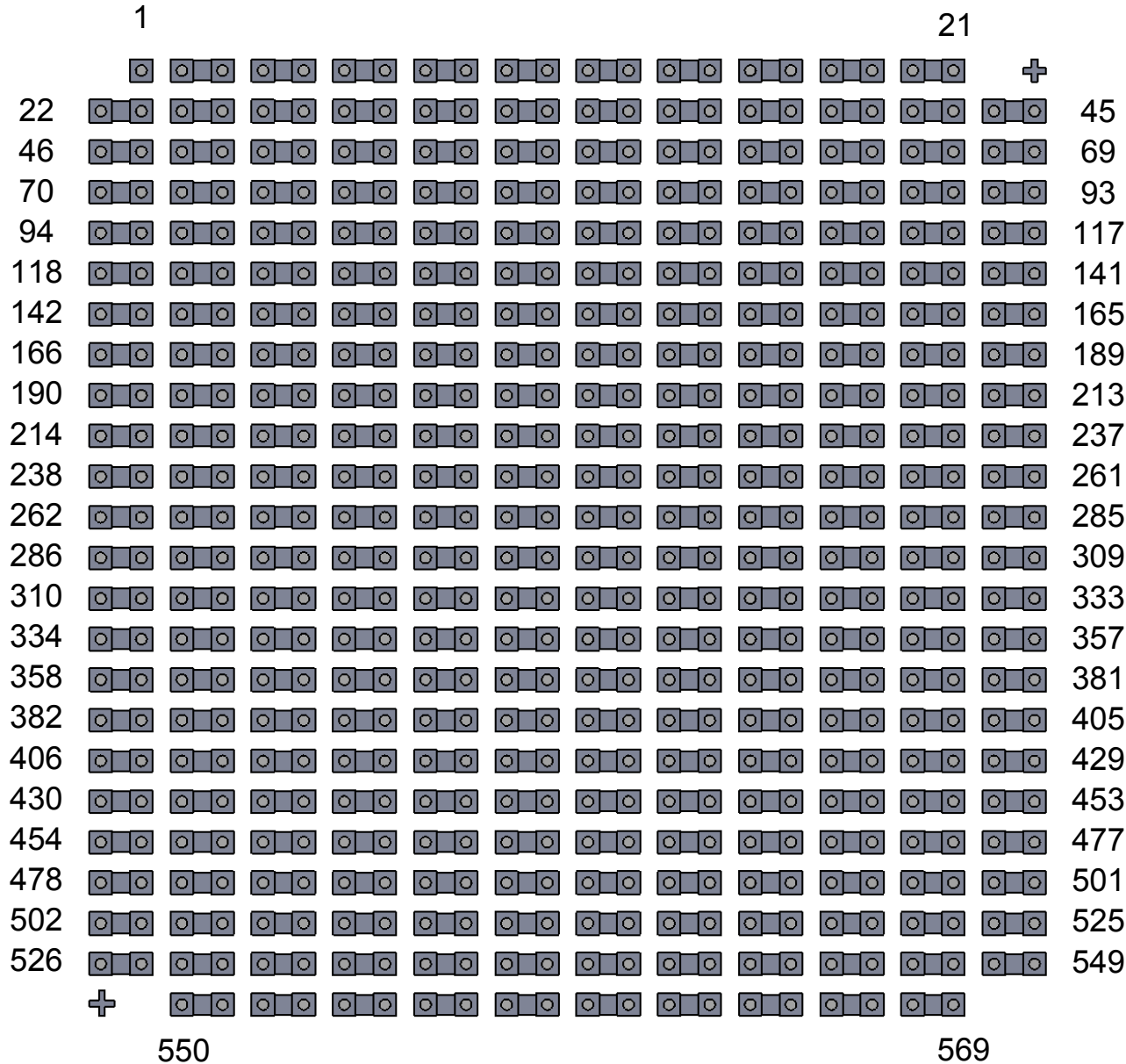

TopLine [®]			
TITLE FC569-204μM PITCH FLIP CHIP 5.08 X 5.08 MM			
SCALE 30:1	SIZE A	DRAWING NO. 181923	REV A
DO NOT SCALE DRAWING			SHEET 5 OF 13

FC569 NET LIST

PIN#	NAME	X	Y
1	Pin1	-1938	-2346
2	Pin2	-1734	-2346
3	Pin3	-1530	-2346
4	Pin4	-1326	-2346
5	Pin5	-1122	-2346
6	Pin6	-918	-2346
7	Pin7	-714	-2346
8	Pin8	-510	-2346
9	Pin9	-306	-2346
10	Pin10	-102	-2346
11	Pin11	102	-2346
12	Pin12	306	-2346
13	Pin13	510	-2346
14	Pin14	714	-2346
15	Pin15	918	-2346
16	Pin16	1122	-2346
17	Pin17	1326	-2346
18	Pin18	1530	-2346
19	Pin19	1734	-2346
20	Pin20	1938	-2346
21	Pin21	-2346	-2142
22	Pin22	-2142	-2142
23	Pin23	-1938	-2142
24	Pin24	-1734	-2142
25	Pin25	-1530	-2142
26	Pin26	-1326	-2142
27	Pin27	-1122	-2142
28	Pin28	-918	-2142
29	Pin29	-714	-2142
30	Pin30	-510	-2142
31	Pin31	-306	-2142
32	Pin32	-102	-2142
33	Pin33	102	-2142
34	Pin34	306	-2142
35	Pin35	510	-2142
36	Pin36	714	-2142
37	Pin37	918	-2142
38	Pin38	1122	-2142
39	Pin39	1326	-2142
40	Pin40	1530	-2142
41	Pin41	1734	-2142
42	Pin42	1938	-2142
43	Pin43	2142	-2142
44	Pin44	2346	-2142
45	Pin45	-2346	-1938

PIN#	NAME	X	Y
46	Pin46	-2142	-1938
47	Pin47	-1938	-1938
48	Pin48	-1734	-1938
49	Pin49	-1530	-1938
50	Pin50	-1326	-1938
51	Pin51	-1122	-1938
52	Pin52	-918	-1938
53	Pin53	-714	-1938
54	Pin54	-510	-1938
55	Pin55	-306	-1938
56	Pin56	-102	-1938
57	Pin57	102	-1938
58	Pin58	306	-1938
59	Pin59	510	-1938
60	Pin60	714	-1938
61	Pin61	918	-1938
62	Pin62	1122	-1938
63	Pin63	1326	-1938
64	Pin64	1530	-1938
65	Pin65	1734	-1938
66	Pin66	1938	-1938
67	Pin67	2142	-1938
68	Pin68	2346	-1938
69	Pin69	-2346	-1734
70	Pin70	-2142	-1734
71	Pin71	-1938	-1734
72	Pin72	-1734	-1734
73	Pin73	-1530	-1734
74	Pin74	-1326	-1734
75	Pin75	-1122	-1734
76	Pin76	-918	-1734
77	Pin77	-714	-1734
78	Pin78	-510	-1734
79	Pin79	-306	-1734
80	Pin80	-102	-1734
81	Pin81	102	-1734
82	Pin82	306	-1734
83	Pin83	510	-1734
84	Pin84	714	-1734
85	Pin85	918	-1734
86	Pin86	1122	-1734
87	Pin87	1326	-1734
88	Pin88	1530	-1734
89	Pin89	1734	-1734
90	Pin90	1938	-1734

PIN#	NAME	X	Y
91	Pin91	2142	-1734
92	Pin92	2346	-1734
93	Pin93	-2346	-1530
94	Pin94	-2142	-1530
95	Pin95	-1938	-1530
96	Pin96	-1734	-1530
97	Pin97	-1530	-1530
98	Pin98	-1326	-1530
99	Pin99	-1122	-1530
100	Pin100	-918	-1530
101	Pin101	-714	-1530
102	Pin102	-510	-1530
103	Pin103	-306	-1530
104	Pin104	-102	-1530
105	Pin105	102	-1530
106	Pin106	306	-1530
107	Pin107	510	-1530
108	Pin108	714	-1530
109	Pin109	918	-1530
110	Pin110	1122	-1530
111	Pin111	1326	-1530
112	Pin112	1530	-1530
113	Pin113	1734	-1530
114	Pin114	1938	-1530
115	Pin115	2142	-1530
116	Pin116	2346	-1530
117	Pin117	-2346	-1326
118	Pin118	-2142	-1326
119	Pin119	-1938	-1326
120	Pin120	-1734	-1326
121	Pin121	-1530	-1326
122	Pin122	-1326	-1326
123	Pin123	-1122	-1326
124	Pin124	-918	-1326
125	Pin125	-714	-1326
126	Pin126	-510	-1326
127	Pin127	-306	-1326
128	Pin128	-102	-1326
129	Pin129	102	-1326
130	Pin130	306	-1326
131	Pin131	510	-1326
132	Pin132	714	-1326
133	Pin133	918	-1326
134	Pin134	1122	-1326
135	Pin135	1326	-1326

PIN#	NAME	X	Y
136	Pin136	1530	-1326
137	Pin137	1734	-1326
138	Pin138	1938	-1326
139	Pin139	2142	-1326
140	Pin140	2346	-1326
141	Pin141	-2346	-1122
142	Pin142	-2142	-1122
143	Pin143	-1938	-1122
144	Pin144	-1734	-1122
145	Pin145	-1530	-1122
146	Pin146	-1326	-1122
147	Pin147	-1122	-1122
148	Pin148	-918	-1122
149	Pin149	-714	-1122
150	Pin150	-510	-1122
151	Pin151	-306	-1122
152	Pin152	-102	-1122
153	Pin153	102	-1122
154	Pin154	306	-1122
155	Pin155	510	-1122
156	Pin156	714	-1122
157	Pin157	918	-1122
158	Pin158	1122	-1122
159	Pin159	1326	-1122
160	Pin160	1530	-1122
161	Pin161	1734	-1122
162	Pin162	1938	-1122
163	Pin163	2142	-1122
164	Pin164	2346	-1122
165	Pin165	-2346	-918
166	Pin166	-2142	-918
167	Pin167	-1938	-918
168	Pin168	-1734	-918
169	Pin169	-1530	-918
170	Pin170	-1326	-918
171	Pin171	-1122	-918
172	Pin172	-918	-918
173	Pin173	-714	-918
174	Pin174	-510	-918
175	Pin175	-306	-918
176	Pin176	-102	-918
177	Pin177	102	-918
178	Pin178	306	-918
179	Pin179	510	-918
180	Pin180	714	-918

NOTES:
 1) DIMENSIONS IN MICRON (μM).
 2) X = 0, Y = 0 IS CENTER OF DIE.

CONTINUE ON PAGE 7

TopLine [®]			
TITLE FC569-204 μM PITCH FLIP CHIP 5.08 X 5.08 MM			
SCALE 10:1	SIZE A	DRAWING NO. 181923	REV A
DO NOT SCALE DRAWING			SHEET 6 OF 13

FC569 NET LIST

PIN#	NAME	X	Y
181	Pin181	918	-918
182	Pin182	1122	-918
183	Pin183	1326	-918
184	Pin184	1530	-918
185	Pin185	1734	-918
186	Pin186	1938	-918
187	Pin187	2142	-918
188	Pin188	2346	-918
189	Pin189	-2346	-714
190	Pin190	-2142	-714
191	Pin191	-1938	-714
192	Pin192	-1734	-714
193	Pin193	-1530	-714
194	Pin194	-1326	-714
195	Pin195	-1122	-714
196	Pin196	-918	-714
197	Pin197	-714	-714
198	Pin198	-510	-714
199	Pin199	-306	-714
200	Pin200	-102	-714
201	Pin201	102	-714
202	Pin202	306	-714
203	Pin203	510	-714
204	Pin204	714	-714
205	Pin205	918	-714
206	Pin206	1122	-714
207	Pin207	1326	-714
208	Pin208	1530	-714
209	Pin209	1734	-714
210	Pin210	1938	-714
211	Pin211	2142	-714
212	Pin212	2346	-714
213	Pin213	-2346	-510
214	Pin214	-2142	-510
215	Pin215	-1938	-510
216	Pin216	-1734	-510
217	Pin217	-1530	-510
218	Pin218	-1326	-510
219	Pin219	-1122	-510
220	Pin220	-918	-510
221	Pin221	-714	-510
222	Pin222	-510	-510
223	Pin223	-306	-510
224	Pin224	-102	-510
225	Pin225	102	-510

PIN#	NAME	X	Y
226	Pin226	306	-510
227	Pin227	510	-510
228	Pin228	714	-510
229	Pin229	918	-510
230	Pin230	1122	-510
231	Pin231	1326	-510
232	Pin232	1530	-510
233	Pin233	1734	-510
234	Pin234	1938	-510
235	Pin235	2142	-510
236	Pin236	2346	-510
237	Pin237	-2346	-306
238	Pin238	-2142	-306
239	Pin239	-1938	-306
240	Pin240	-1734	-306
241	Pin241	-1530	-306
242	Pin242	-1326	-306
243	Pin243	-1122	-306
244	Pin244	-918	-306
245	Pin245	-714	-306
246	Pin246	-510	-306
247	Pin247	-306	-306
248	Pin248	-102	-306
249	Pin249	102	-306
250	Pin250	306	-306
251	Pin251	510	-306
252	Pin252	714	-306
253	Pin253	918	-306
254	Pin254	1122	-306
255	Pin255	1326	-306
256	Pin256	1530	-306
257	Pin257	1734	-306
258	Pin258	1938	-306
259	Pin259	2142	-306
260	Pin260	2346	-306
261	Pin261	-2346	-102
262	Pin262	-2142	-102
263	Pin263	-1938	-102
264	Pin264	-1734	-102
265	Pin265	-1530	-102
266	Pin266	-1326	-102
267	Pin267	-1122	-102
268	Pin268	-918	-102
269	Pin269	-714	-102
270	Pin270	-510	-102

PIN#	NAME	X	Y
271	Pin271	-306	-102
272	Pin272	-102	-102
273	Pin273	102	-102
274	Pin274	306	-102
275	Pin275	510	-102
276	Pin276	714	-102
277	Pin277	918	-102
278	Pin278	1122	-102
279	Pin279	1326	-102
280	Pin280	1530	-102
281	Pin281	1734	-102
282	Pin282	1938	-102
283	Pin283	2142	-102
284	Pin284	2346	-102
285	Pin285	-2346	102
286	Pin286	-2142	102
287	Pin287	-1938	102
288	Pin288	-1734	102
289	Pin289	-1530	102
290	Pin290	-1326	102
291	Pin291	-1122	102
292	Pin292	-918	102
293	Pin293	-714	102
294	Pin294	-510	102
295	Pin295	-306	102
296	Pin296	-102	102
297	Pin297	102	102
298	Pin298	306	102
299	Pin299	510	102
300	Pin300	714	102
301	Pin301	918	102
302	Pin302	1122	102
303	Pin303	1326	102
304	Pin304	1530	102
305	Pin305	1734	102
306	Pin306	1938	102
307	Pin307	2142	102
308	Pin308	2346	102
309	Pin309	-2346	306
310	Pin310	-2142	306
311	Pin311	-1938	306
312	Pin312	-1734	306
313	Pin313	-1530	306
314	Pin314	-1326	306
315	Pin315	-1122	306

PIN#	NAME	X	Y
316	Pin316	-918	306
317	Pin317	-714	306
318	Pin318	-510	306
319	Pin319	-306	306
320	Pin320	-102	306
321	Pin321	102	306
322	Pin322	306	306
323	Pin323	510	306
324	Pin324	714	306
325	Pin325	918	306
326	Pin326	1122	306
327	Pin327	1326	306
328	Pin328	1530	306
329	Pin329	1734	306
330	Pin330	1938	306
331	Pin331	2142	306
332	Pin332	2346	306
333	Pin333	-2346	510
334	Pin334	-2142	510
335	Pin335	-1938	510
336	Pin336	-1734	510
337	Pin337	-1530	510
338	Pin338	-1326	510
339	Pin339	-1122	510
340	Pin340	-918	510
341	Pin341	-714	510
342	Pin342	-510	510
343	Pin343	-306	510
344	Pin344	-102	510
345	Pin345	102	510
346	Pin346	306	510
347	Pin347	510	510
348	Pin348	714	510
349	Pin349	918	510
350	Pin350	1122	510
351	Pin351	1326	510
352	Pin352	1530	510
353	Pin353	1734	510
354	Pin354	1938	510
355	Pin355	2142	510
356	Pin356	2346	510
357	Pin357	-2346	714
358	Pin358	-2142	714
359	Pin359	-1938	714
360	Pin360	-1734	714

NOTES:
 1) DIMENSIONS IN MICRON (μM).
 2) X = 0, Y = 0 IS CENTER OF DIE.

CONTINUE ON PAGE 8

TopLine[®]

TITLE FC569-204 μM PITCH
 FLIP CHIP 5.08 X 5.08 MM

SCALE 10:1	SIZE A	DRAWING NO. 181923	REV A
---------------	-----------	-----------------------	----------

DO NOT SCALE DRAWING

SHEET 7 OF 13

FC569 NET LIST

PIN#	NAME	X	Y
361	Pin361	-1530	714
362	Pin362	-1326	714
363	Pin363	-1122	714
364	Pin364	-918	714
365	Pin365	-714	714
366	Pin366	-510	714
367	Pin367	-306	714
368	Pin368	-102	714
369	Pin369	102	714
370	Pin370	306	714
371	Pin371	510	714
372	Pin372	714	714
373	Pin373	918	714
374	Pin374	1122	714
375	Pin375	1326	714
376	Pin376	1530	714
377	Pin377	1734	714
378	Pin378	1938	714
379	Pin379	2142	714
380	Pin380	2346	714
381	Pin381	-2346	918
382	Pin382	-2142	918
383	Pin383	-1938	918
384	Pin384	-1734	918
385	Pin385	-1530	918
386	Pin386	-1326	918
387	Pin387	-1122	918
388	Pin388	-918	918
389	Pin389	-714	918
390	Pin390	-510	918
391	Pin391	-306	918
392	Pin392	-102	918
393	Pin393	102	918
394	Pin394	306	918
395	Pin395	510	918
396	Pin396	714	918
397	Pin397	918	918
398	Pin398	1122	918
399	Pin399	1326	918
400	Pin400	1530	918
401	Pin401	1734	918
402	Pin402	1938	918
403	Pin403	2142	918
404	Pin404	2346	918
405	Pin405	-2346	1122

PIN#	NAME	X	Y
406	Pin406	-2142	1122
407	Pin407	-1938	1122
408	Pin408	-1734	1122
409	Pin409	-1530	1122
410	Pin410	-1326	1122
411	Pin411	-1122	1122
412	Pin412	-918	1122
413	Pin413	-714	1122
414	Pin414	-510	1122
415	Pin415	-306	1122
416	Pin416	-102	1122
417	Pin417	102	1122
418	Pin418	306	1122
419	Pin419	510	1122
420	Pin420	714	1122
421	Pin421	918	1122
422	Pin422	1122	1122
423	Pin423	1326	1122
424	Pin424	1530	1122
425	Pin425	1734	1122
426	Pin426	1938	1122
427	Pin427	2142	1122
428	Pin428	2346	1122
429	Pin429	-2346	1326
430	Pin430	-2142	1326
431	Pin431	-1938	1326
432	Pin432	-1734	1326
433	Pin433	-1530	1326
434	Pin434	-1326	1326
435	Pin435	-1122	1326
436	Pin436	-918	1326
437	Pin437	-714	1326
438	Pin438	-510	1326
439	Pin439	-306	1326
440	Pin440	-102	1326
441	Pin441	102	1326
442	Pin442	306	1326
443	Pin443	510	1326
444	Pin444	714	1326
445	Pin445	918	1326
446	Pin446	1122	1326
447	Pin447	1326	1326
448	Pin448	1530	1326
449	Pin449	1734	1326
450	Pin450	1938	1326

PIN#	NAME	X	Y
451	Pin451	2142	1326
452	Pin452	2346	1326
453	Pin453	-2346	1530
454	Pin454	-2142	1530
455	Pin455	-1938	1530
456	Pin456	-1734	1530
457	Pin457	-1530	1530
458	Pin458	-1326	1530
459	Pin459	-1122	1530
460	Pin460	-918	1530
461	Pin461	-714	1530
462	Pin462	-510	1530
463	Pin463	-306	1530
464	Pin464	-102	1530
465	Pin465	102	1530
466	Pin466	306	1530
467	Pin467	510	1530
468	Pin468	714	1530
469	Pin469	918	1530
470	Pin470	1122	1530
471	Pin471	1326	1530
472	Pin472	1530	1530
473	Pin473	1734	1530
474	Pin474	1938	1530
475	Pin475	2142	1530
476	Pin476	2346	1530
477	Pin477	-2346	1734
478	Pin478	-2142	1734
479	Pin479	-1938	1734
480	Pin480	-1734	1734
481	Pin481	-1530	1734
482	Pin482	-1326	1734
483	Pin483	-1122	1734
484	Pin484	-918	1734
485	Pin485	-714	1734
486	Pin486	-510	1734
487	Pin487	-306	1734
488	Pin488	-102	1734
489	Pin489	102	1734
490	Pin490	306	1734
491	Pin491	510	1734
492	Pin492	714	1734
493	Pin493	918	1734
494	Pin494	1122	1734
495	Pin495	1326	1734

PIN#	NAME	X	Y
496	Pin496	1530	1734
497	Pin497	1734	1734
498	Pin498	1938	1734
499	Pin499	2142	1734
500	Pin500	2346	1734
501	Pin501	-2346	1938
502	Pin502	-2142	1938
503	Pin503	-1938	1938
504	Pin504	-1734	1938
505	Pin505	-1530	1938
506	Pin506	-1326	1938
507	Pin507	-1122	1938
508	Pin508	-918	1938
509	Pin509	-714	1938
510	Pin510	-510	1938
511	Pin511	-306	1938
512	Pin512	-102	1938
513	Pin513	102	1938
514	Pin514	306	1938
515	Pin515	510	1938
516	Pin516	714	1938
517	Pin517	918	1938
518	Pin518	1122	1938
519	Pin519	1326	1938
520	Pin520	1530	1938
521	Pin521	1734	1938
522	Pin522	1938	1938
523	Pin523	2142	1938
524	Pin524	2346	1938
525	Pin525	-2346	2142
526	Pin526	-2142	2142
527	Pin527	-1938	2142
528	Pin528	-1734	2142
529	Pin529	-1530	2142
530	Pin530	-1326	2142
531	Pin531	-1122	2142
532	Pin532	-918	2142
533	Pin533	-714	2142
534	Pin534	-510	2142
535	Pin535	-306	2142
536	Pin536	-102	2142
537	Pin537	102	2142
538	Pin538	306	2142
539	Pin539	510	2142
540	Pin540	714	2142

NOTES:

- 1) DIMENSIONS IN MICRON (μM).
- 2) X = 0, Y = 0 IS CENTER OF DIE.

CONTINUE ON PAGE 9

TopLine [®]			
TITLE FC569-204 μM PITCH FLIP CHIP 5.08 X 5.08 MM			
SCALE 10:1	SIZE A	DRAWING NO. 181923	REV A
DO NOT SCALE DRAWING			SHEET 8 OF 13

FC569 NET LIST

PIN#	NAME	X	Y
541	Pin541	918	2142
542	Pin542	1122	2142
543	Pin543	1326	2142
544	Pin544	1530	2142
545	Pin545	1734	2142
546	Pin546	1938	2142
547	Pin547	2142	2142
548	Pin548	2346	2142
549	Pin549	-2142	2346
550	Pin550	-1938	2346
551	Pin551	-1734	2346
552	Pin552	-1530	2346
553	Pin553	-1326	2346
554	Pin554	-1122	2346
555	Pin555	-918	2346
556	Pin556	-714	2346
557	Pin557	-510	2346
558	Pin558	-306	2346
559	Pin559	-102	2346
560	Pin560	102	2346
561	Pin561	306	2346
562	Pin562	510	2346
563	Pin563	714	2346
564	Pin564	918	2346
565	Pin565	1122	2346
566	Pin566	1326	2346
567	Pin567	1530	2346
568	Pin568	1734	2346
569	Pin569	1938	2346

NOTES:

- 1) DIMENSIONS IN MICRON (μM).
- 2) X = 0, Y = 0 IS CENTER OF DIE.

TopLine[®]			
TITLE FC569-204 μM PITCH FLIP CHIP 5.08 X 5.08 MM			
SCALE 10:1	SIZE A	DRAWING NO. 181923	REV A
DO NOT SCALE DRAWING		SHEET 9 OF 13	

9-UP DIE - FC5121

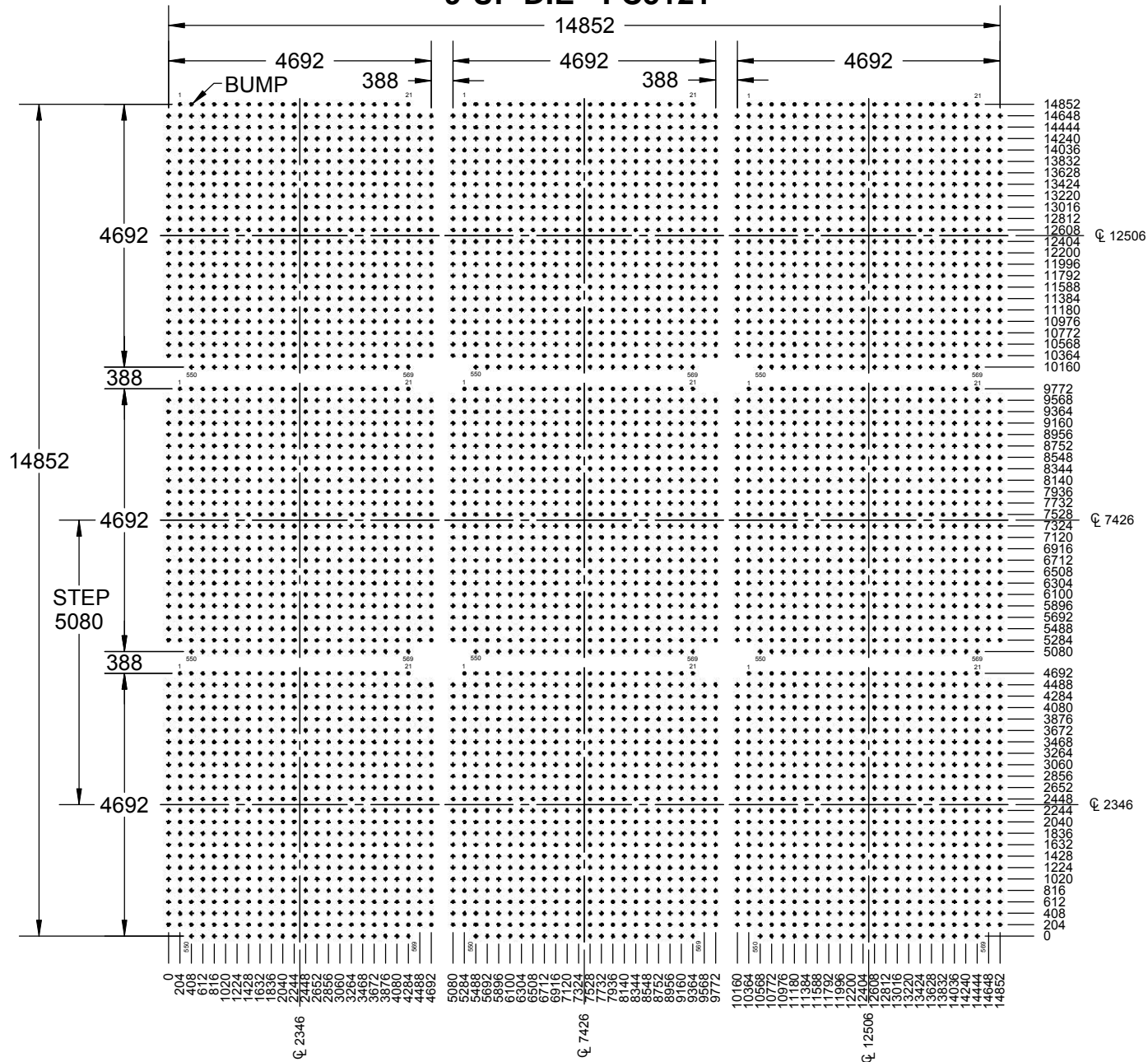

SOLDER BUMP PAD DETAIL 1

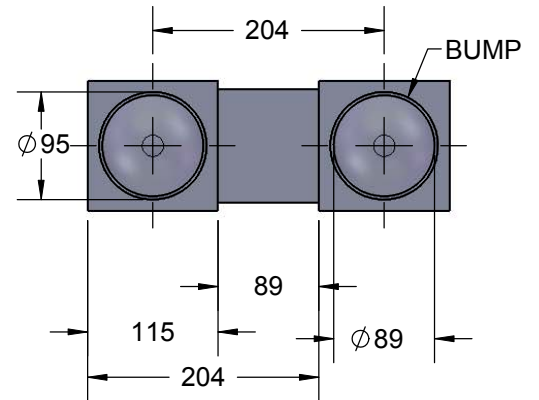

WIRE BONDING PAD DETAIL 2

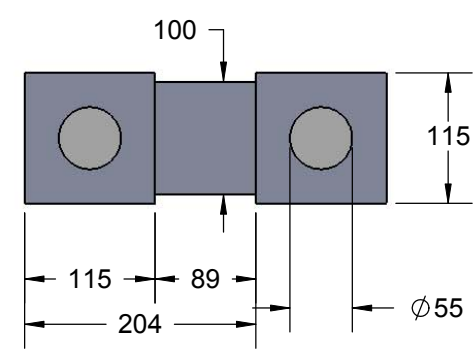

PART NUMBER TABLE

PART NUMBER	BUMP ALLOY	Pb-Free	BUMP	DETAIL
FC5121G15C204-DC	SAC - SnAgCu	YES	YES	1
FC5121G15E204-DC	SnPb Eutectic	NO	YES	1
FCN5121G15A204-DC	Al - BUMPLESS	YES	NO	2



TITLE FC569-204μM PITCH FLIP CHIP 5.08 X 5.08 MM			
SCALE 9:1	SIZE A	DRAWING NO. 181923	REV A
DO NOT SCALE DRAWING			SHEET 11 OF 13

16-UP DIE - FC9104

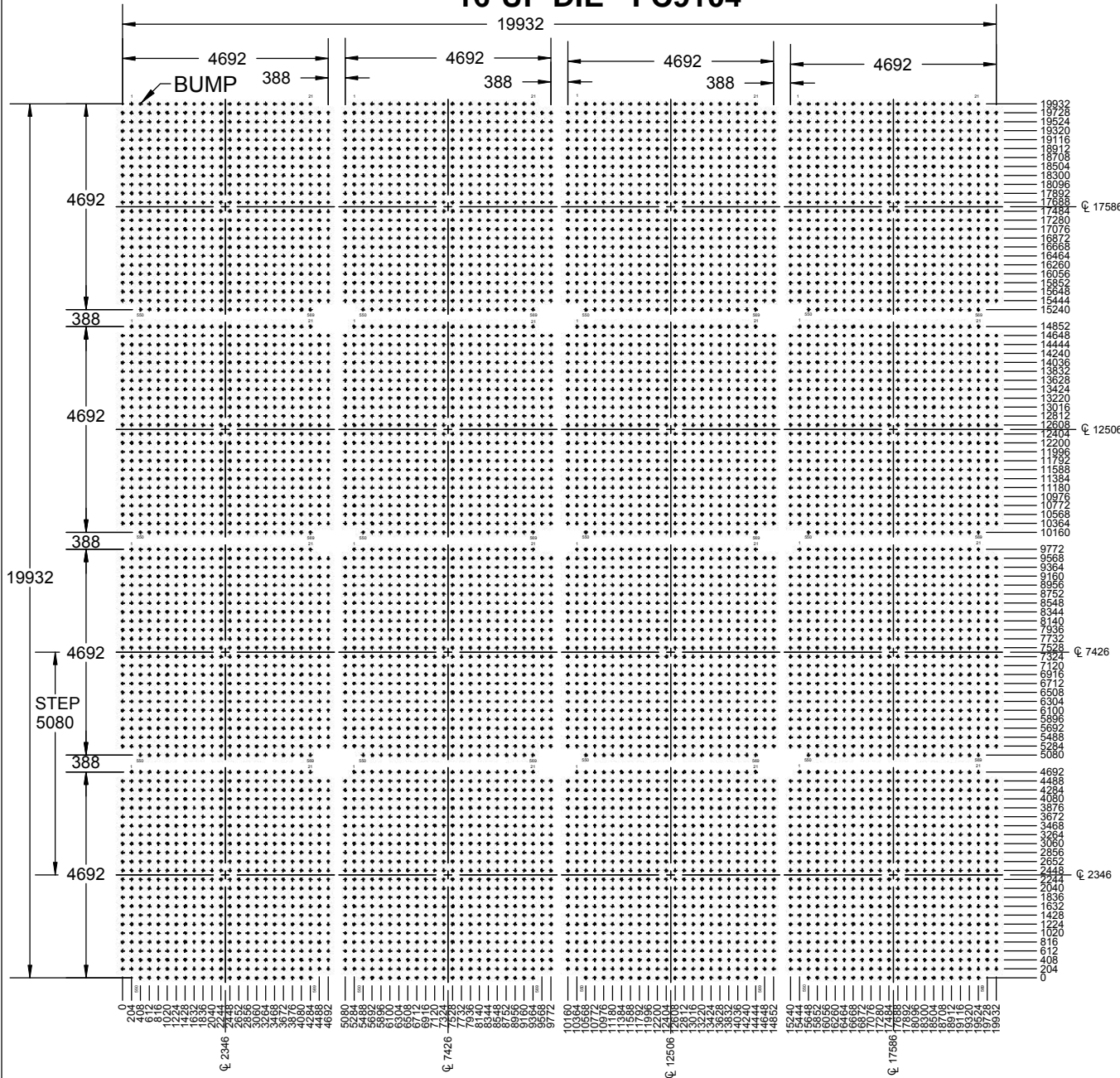

SOLDER BUMP PAD DETAIL 1

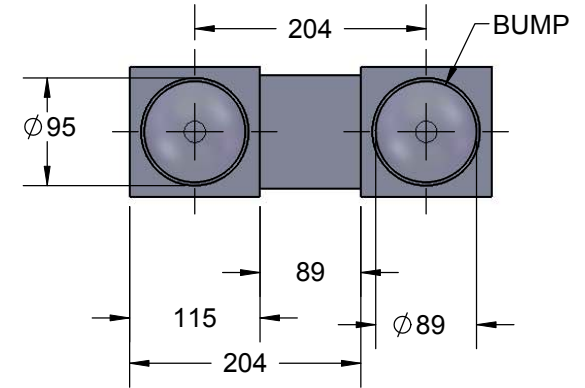

WIRE BONDING PAD DETAIL 2

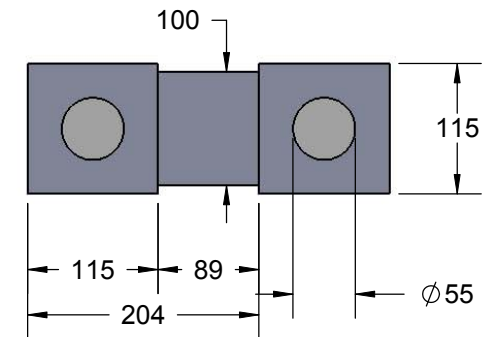

PART NUMBER TABLE

PART NUMBER	BUMP ALLOY	Pb-Free	BUMP	DETAIL
FC9104G20C204-DC	SAC - SnAgCu	YES	YES	1
FC9104G20E204-DC	SnPb Eutectic	NO	YES	1
FCN9104G20A204-DC	Al - BUMPLESS	YES	NO	2

TopLine

TITLE FC569-204μM PITCH
FLIP CHIP 5.08 X 5.08 MM

SCALE 7:1	SIZE A	DRAWING NO. 181923	REV A
--------------	-----------	-----------------------	----------

DO NOT SCALE DRAWING

SHEET 12 OF 13

PART NUMBERING SYSTEM

FC

569

G

5.08

C

204

- ATTACH -

DC

- OPTION

FLIP CHIP

FC = STANDARD FLIP CHIP
 FCW = BUMPED WAFER*
 FCN = BUMPLESS CHIP
 FCWN = BUMPLESS WAFER*

* 5-INCH WAFER

NUMBER BUMPS

BUMP	DIE ARRAY
569	1X
2276	4X
5121	9X
9104	16X

BUMP DIAMETER

DIAM ϕ 89 μ M
 HEIGHT 95 μ M

DIE SIZE

BUMP	MM	MILS
569	5.08MM	200
2276	10MM	400
5121	15MM	600
9104	20MM	800

BUMP MATERIALI

E = EUTECTIC Sn63
 C = LEAD FREE SAC
 A = AI PAD (BUMPLESS)
 FOR WIREBONDING

BUMP PITCH

μ M

OPTIONS

BLANK = STANDARD
 NON-METAL

M = METAL BACK SIDE
 FOR EUTECTIC
 SOLDER

DIE THINNING

CODE	μ M	INCH
NONE	635 μ M	.025"
BG530	530 μ M	.021"
BG430	430 μ M	.017"
BG360	360 μ M	.014"
BG250	250 μ M	.010"

DAISY CHAIN

PACKAGING

BLANK = TRAY (STANDARD)

BUMP	TRAY	QTY
569	2-INCH	36PCS
2276	4-INCH	49PCS
5121	4-INCH	25PCS
9104	4-INCH	9PCS

TR = TAPE & REEL

UVR = UV TAPE
 WAFER RING

NTR = NON UV TAPE
 WAFER RING



TITLE FC569-204 μ M PITCH FLIP CHIP 5.08 X 5.08 MM			
SCALE 10:1	SIZE A	DRAWING NO. 181923	REV A
DO NOT SCALE DRAWING		SHEET 13 OF 13	