

TOP VIEW

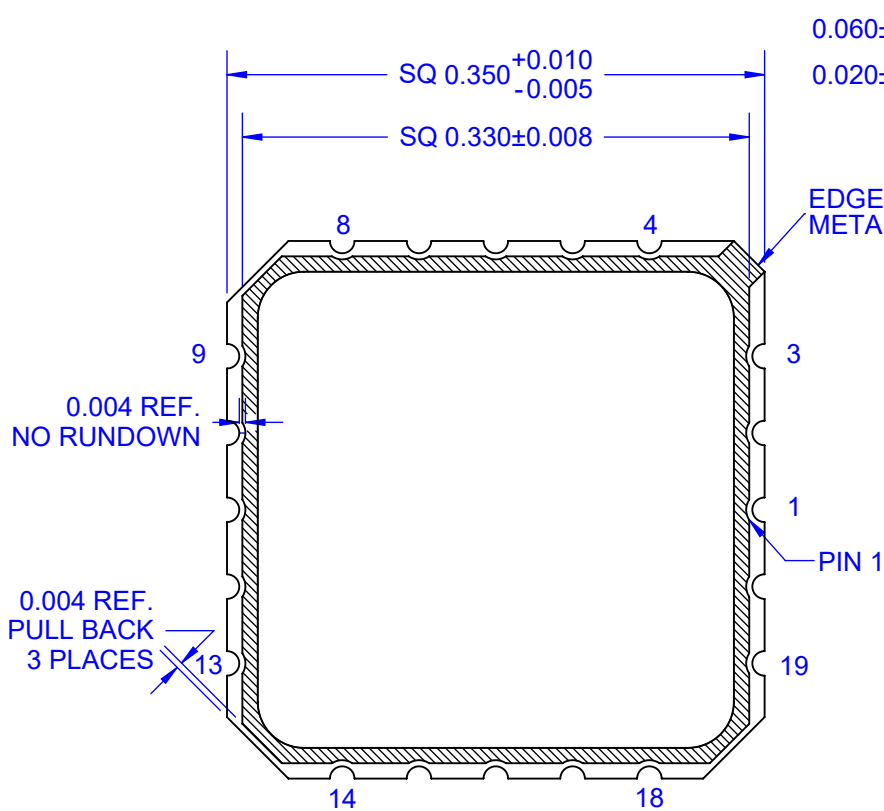

SIDE VIEW

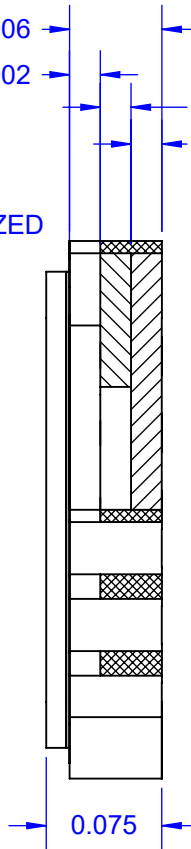

BOTTOM VIEW

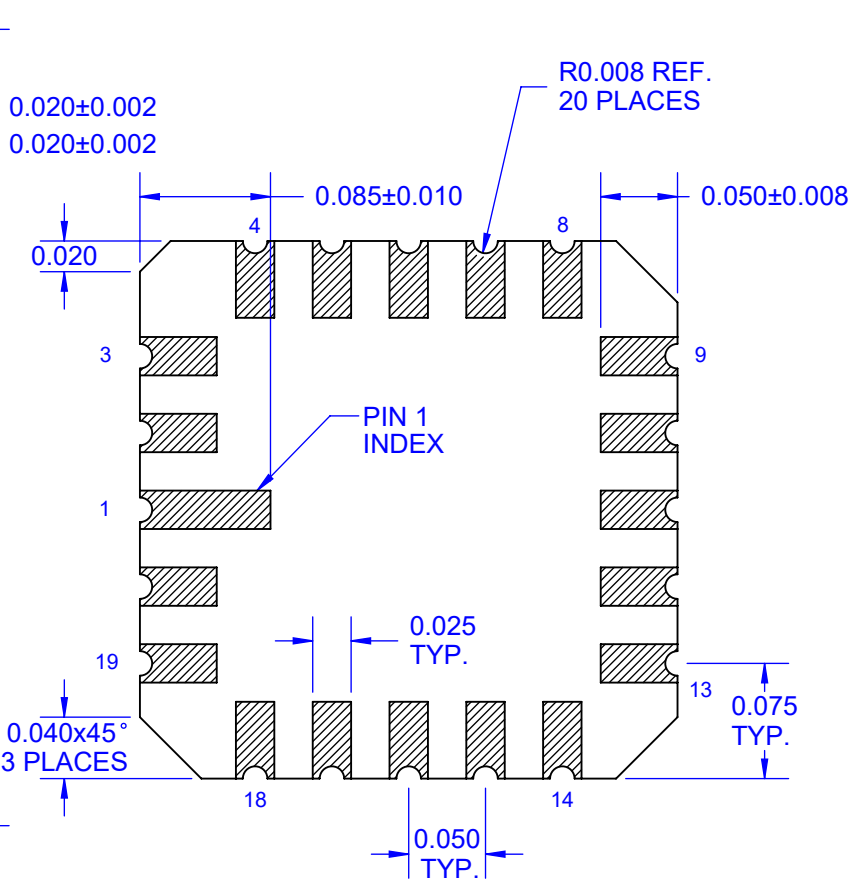

DIE PAD
0.160 x 0.160-inch
[4.06 x 4.06mm]

NOTES: (Unless Otherwise Specified).

- 1) PLATING:
 Ni 80 Micro-inch (2.0um) MIN.
 Au 60 Micro-inch (1.5um) MIN.
- 2) DIMENSION in INCH.

PART NUMBER	COVER	PLATING	DAISY CHAIN
LCC20B50SQ.35-N	OPEN	NiAu	NO
LCC20B50SQ.35	SEALED	NiAu	NO
LCC20B50SQ.35-SC	SEALED	SnPb	NO
LCC20B50SQ.35-DE	SEALED	NiAu	YES
LCC20B50SQ.35-DE-SC	SEALED	SnPb	YES

APPROVALS	DATE				
DRAWN T.Au	11/03/16				
ENG M. Hart	11/03/16	TITLE LCC20B50SQ.35			
MFG		SCALE 10:1	SIZE A	DRAWING NO. 142000	REV A
QA					
CUST		DO NOT SCALE DRAWING			SHEET 1 OF 3
REVISED					

LCC20B50SQ.35-DE DAISY CHAIN

TOP VIEW

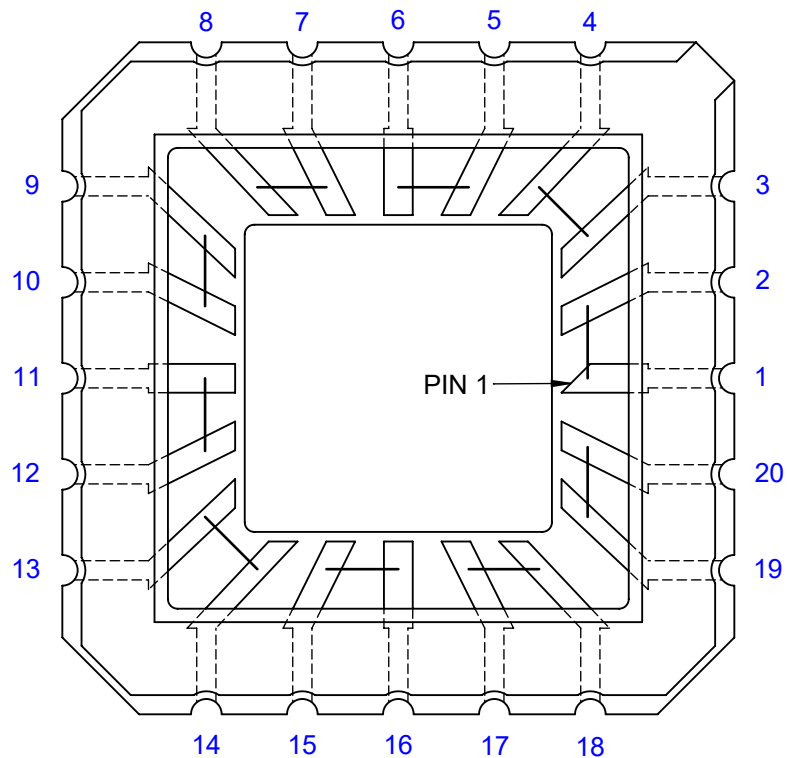

BOTTOM VIEW

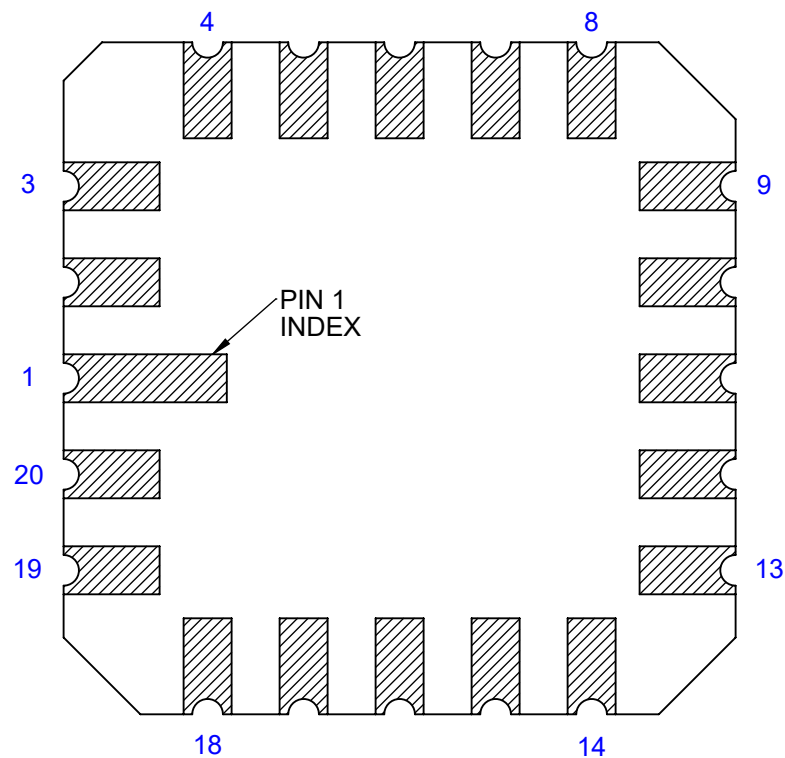

DAISY CHAIN TABLE

FROM / TO	FROM / TO	FROM / TO
1 ~ 2	9 ~ 10	17 ~ 18
3 ~ 4	11 ~ 12	19 ~ 20
5 ~ 6	13 ~ 14	
7 ~ 8	15 ~ 16	

TopLine[®]

TITLE LCC20B50SQ.35

SCALE 16:1	SIZE A	DRAWING NO. 142000	REV A
---------------	-----------	-----------------------	----------

DO NOT SCALE DRAWING

SHEET 2 OF 3

MODEL

TOP

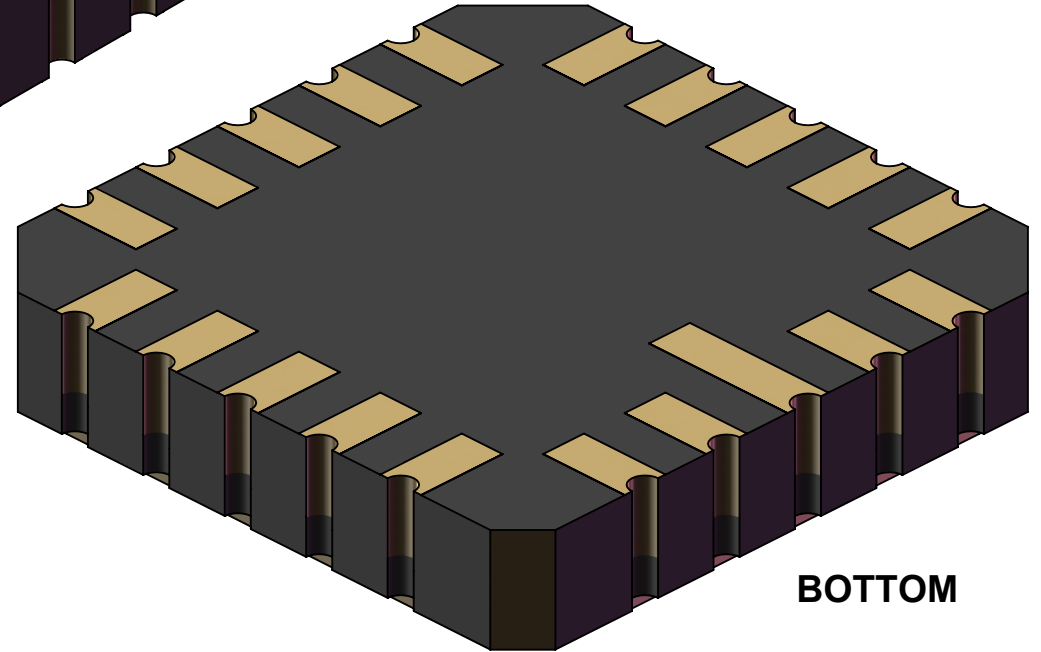
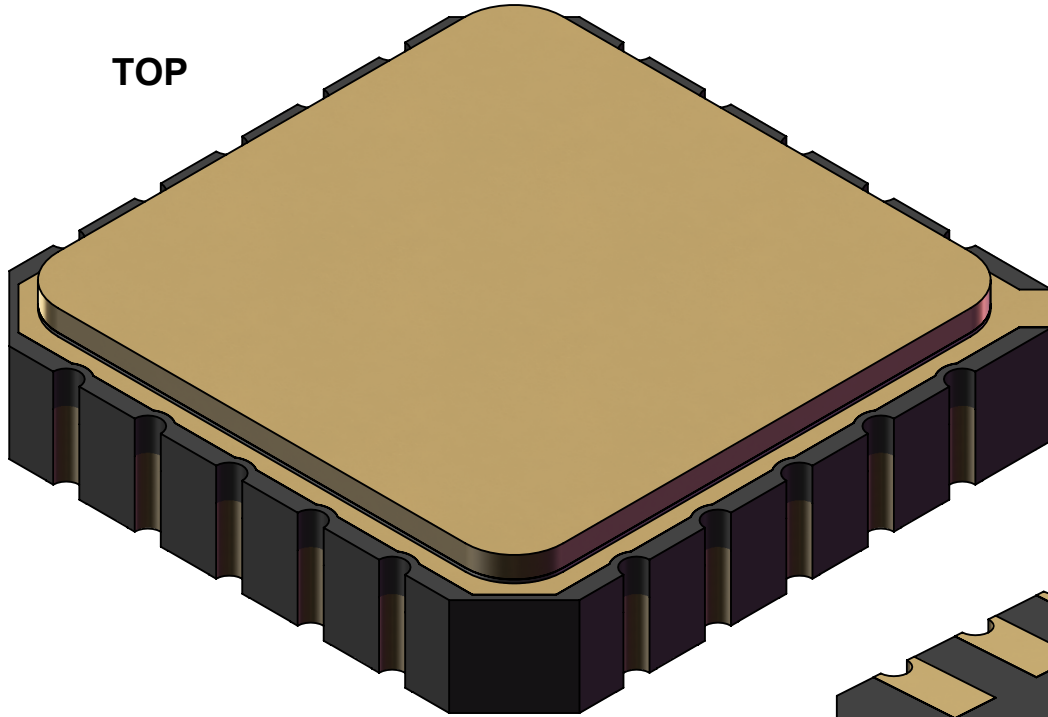

BOTTOM

TopLine[®]

TITLE LCC20B50SQ.35

SCALE 12:1	SIZE A	DRAWING NO. 142000	REV A
---------------	-----------	-----------------------	----------

DO NOT SCALE DRAWING SHEET 3 OF 3