

FLIP CHIP GLASS STAND-OFF BOARD CONTROLLED HEIGHT FOR UNDERFILL

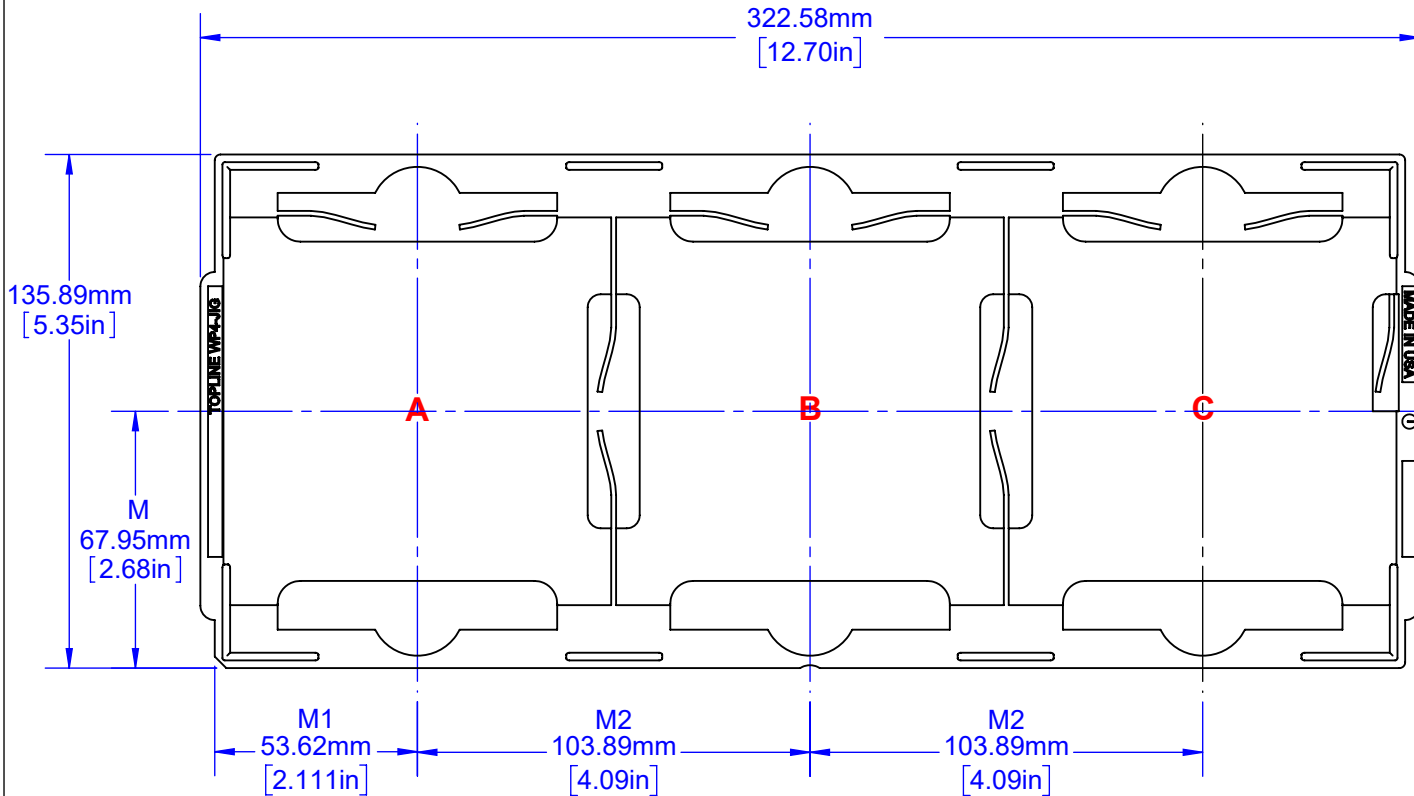

PART NUMBER TABLE*		
LOCATION	STAND-OFF HEIGHT	BOARD PN
A	50 μ m \pm 15 μ m	959050
B	100 μ m \pm 20 μ m	959100
C	125 μ m \pm 25 μ m	959125
FULL SET	HELD IN PLACE IN JEDEC TRAY	959000

BOARD DELIVERED WITH GLASS DIE
ATTACHED WITH
CYANOACRYLATE GLUE GEL

Unit	Pocket N3	Column N1	Rows N2	Row 1 M	Col 1 M1	Col 2 M2
Inch	3.1	3	1	2.675	2.111	4.090
mm	3.1	3	1	67.95	53.62	103.89

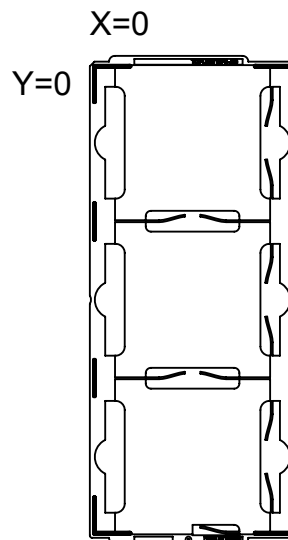

NOTES: (UNLESS OTHERWISE SPECIFIED).

1. DIMENSIONS: mm [INCH].
2. STAND-OFF HEIGHT: SEE PART NUMBER TABLE.
3. STAND-OFF MATERIAL: NON-COLLAPSIBLE POSTS.
4. BOARD MATERIAL FR4 WITH GREEN SOLDER MASK.
5. BOARDS INCLUDE GLASS SLUGS (ASSEMBLED).
6. SEE PAGE 9 FOR SPARE GLASS COMPONENTS.

APPROVALS		DATE	TopLine [®]			
DRAWN	T. Au	04/06/2024				
ENG	M. Hart	04/06/2024	TITLE FLIP CHIP STAND-OFF BOARD CONTROLLED HEIGHT UNDERFILL			
MFG						
QA			SCALE	SIZE	DRAWING NO.	REV
CUST			1:2	A	959000	A
REVISED			DO NOT SCALE DRAWING			SHEET 1 OF 9

FLIP CHIP GLASS 50um STAND-OFF (A)

SIDE VIEW

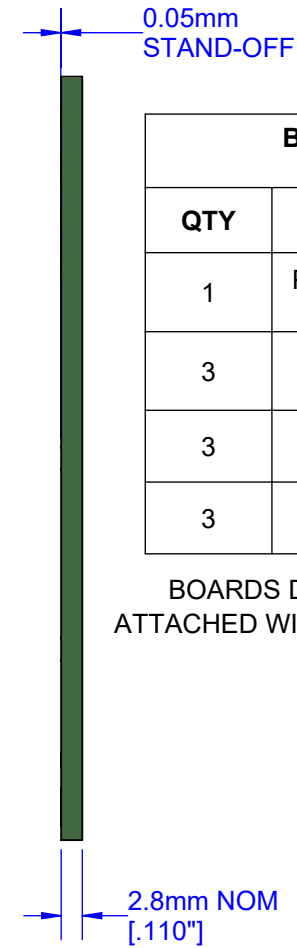
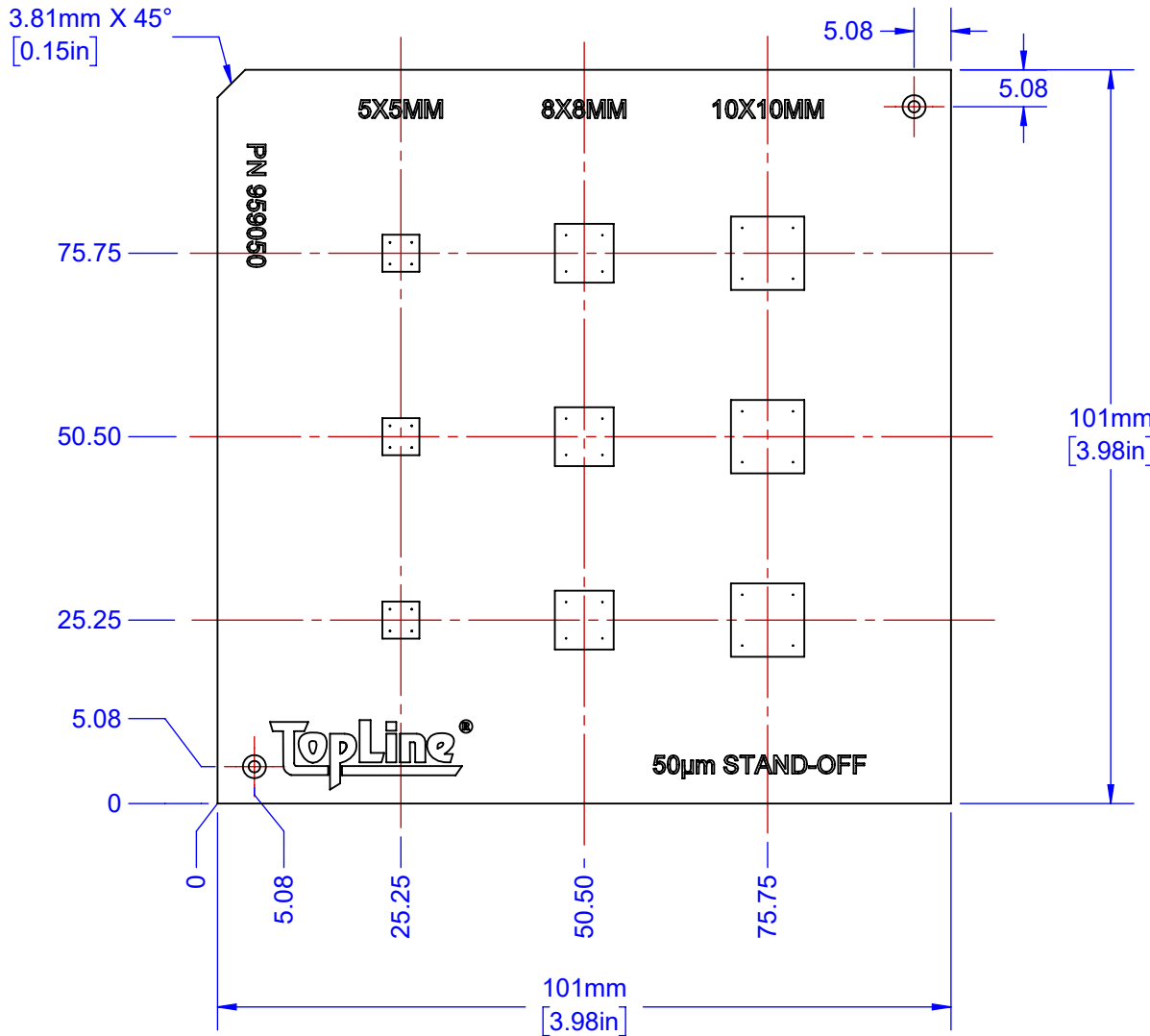

BILL OF MATERIALS BOARD 959050 (A)		
QTY	DESCRIPTION	DWG
1	PCB 50um (2mil) STAND-OFF	959050
3	GLASS DIE 5x5mm	XXXXXX
3	GLASS DIE 8x8mm	XXXXXX
3	GLASS DIE 10x10mm	XXXXXX

BOARDS DELIVERED WITH GLASS DIE
ATTACHED WITH CYANOACRYLATE GLUE GEL

GLOBAL FIDUCIAL

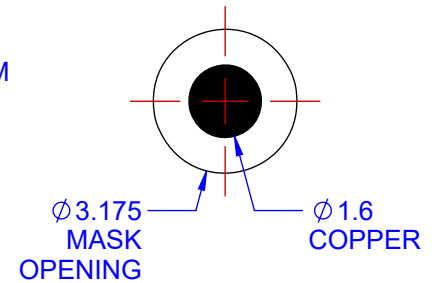

NOTES: (UNLESS OTHERWISE SPECIFIED).

1. DIMENSIONS mm.
2. STAND-OFF HEIGHT - SEE PART NUMBER TABLE.
3. STAND-OFF MATERIAL: NON-COLLAPSIBLE POSTS.
4. BOARD MATERIAL: FR4 WITH GREEN SOLDER MASK.
5. BOARDS INCLUDE GLASS SLUGS (ASSEMBLED).
6. SEE PAGE 9 FOR SPARE GLASS COMPONENTS.



TITLE FLIP CHIP STAND-OFF BOARD
CONTROLLED HEIGHT UNDERFILL

SCALE 1:1	SIZE A	DRAWING NO. 959000	REV A
--------------	-----------	-----------------------	----------

DO NOT SCALE DRAWING

SHEET 2 OF 9

FLIP CHIP GLASS 100um STAND-OFF (B)

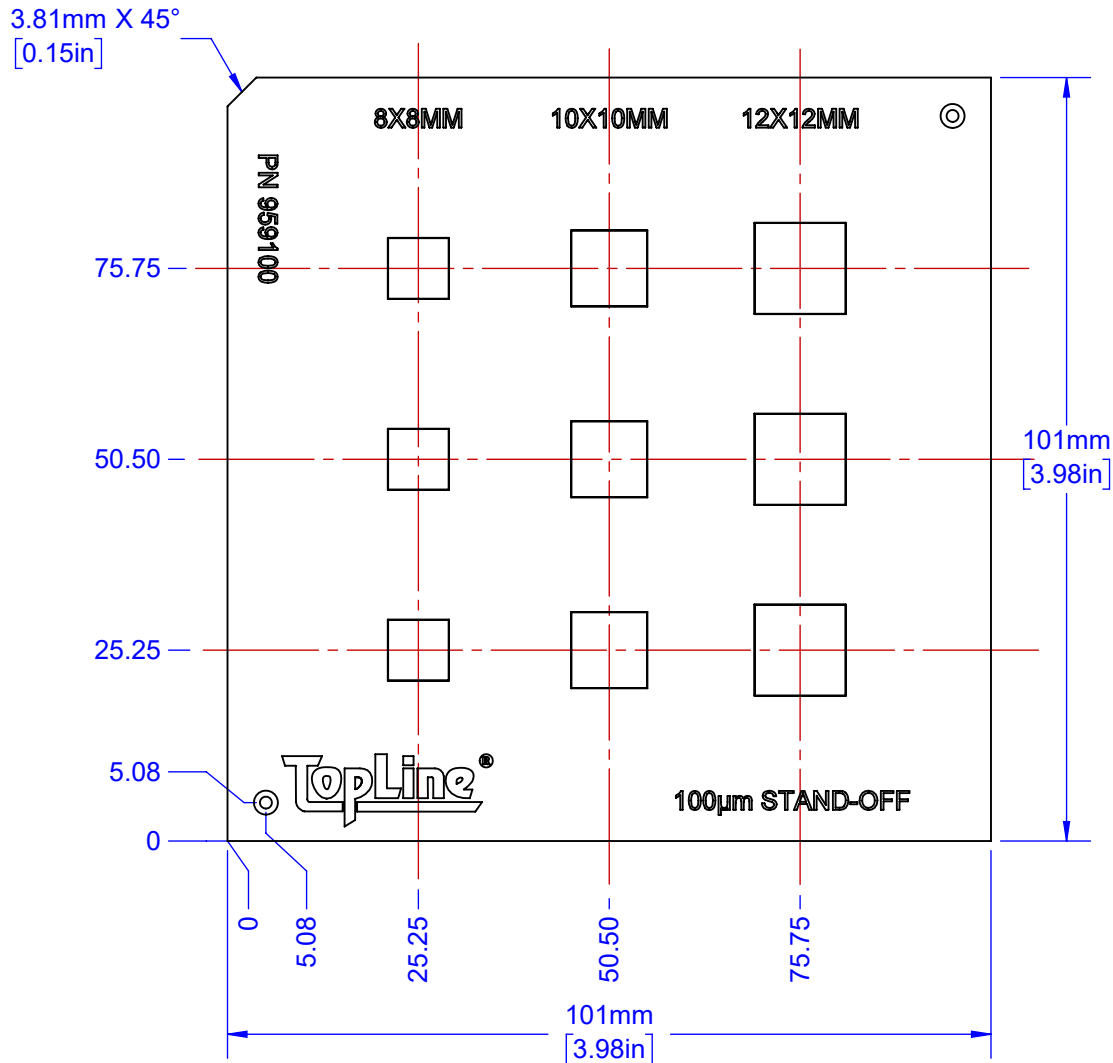

NOTES: (UNLESS OTHERWISE SPECIFIED).

1. DIMENSIONS mm.
2. STAND-OFF HEIGHT - SEE PART NUMBER TABLE.
3. STAND-OFF MATERIAL: NON-COLLAPSIBLE POSTS.
4. BOARD MATERIAL: FR4 WITH GREEN SOLDER MASK.
5. BOARDS INCLUDE GLASS SLUGS (ASSEMBLED).
6. SEE PAGE 9 FOR SPARE GLASS COMPONENTS.

SIDE VIEW

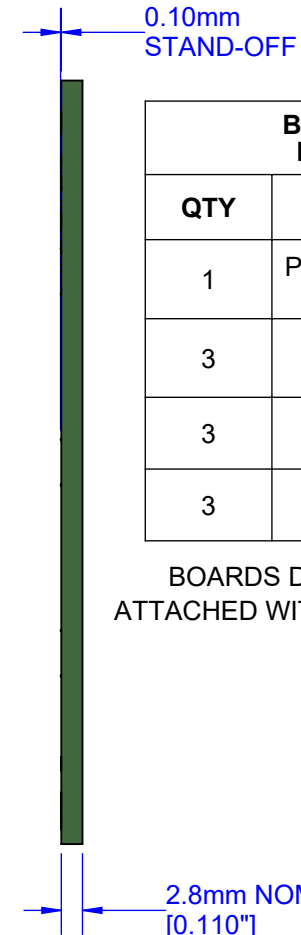

BILL OF MATERIALS BOARD 959100 (B)		
QTY	DESCRIPTION	DWG
1	PCB 100um (4mil) STAND-OFF	959100
3	GLASS DIE 8x8mm	XXXXXX
3	GLASS DIE 10x10mm	XXXXXX
3	GLASS DIE 12x12mm	XXXXXX

BOARDS DELIVERED WITH GLASS DIE
ATTACHED WITH CYANOACRYLATE GLUE GEL

GLOBAL FIDUCIAL

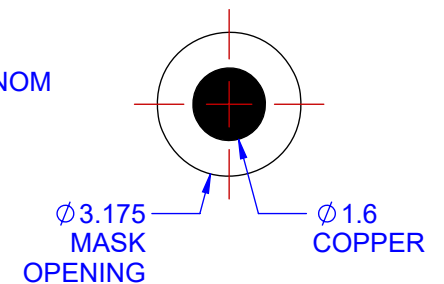

TopLine®

TITLE FLIP CHIP STAND-OFF BOARD
CONTROLLED HEIGHT UNDERFILL

SCALE	SIZE	DRAWING NO.	REV
1:1	A	959000	A

DO NOT SCALE DRAWING

SHEET 3 OF 9

FLIP CHIP GLASS 125um STAND-OFF (C)

SIDE VIEW

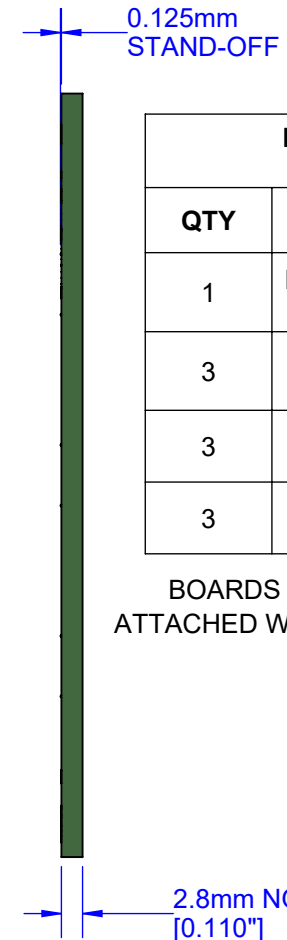
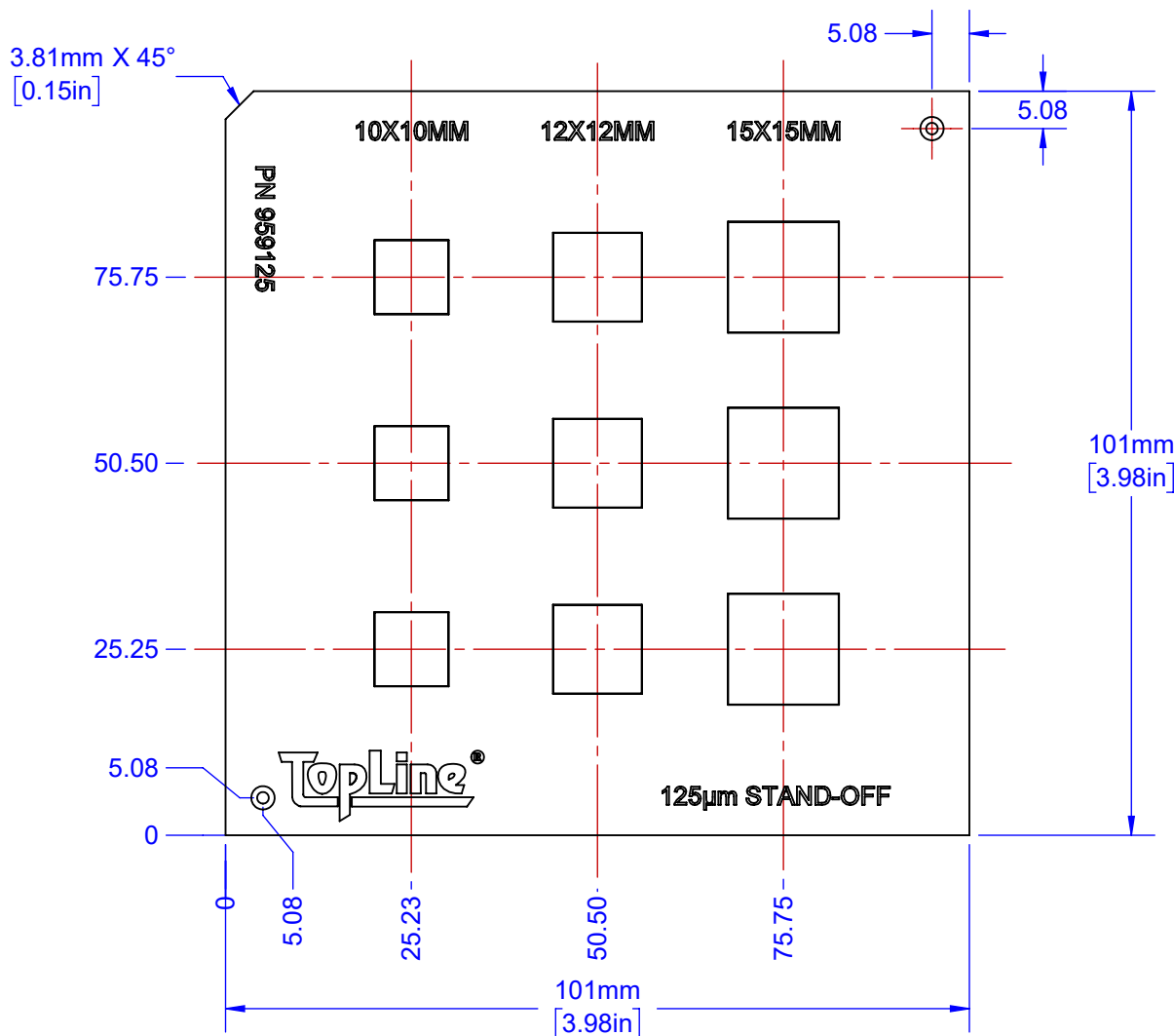

BILL OF MATERIALS BOARD 959125 (C)		
QTY	DESCRIPTION	DWG
1	PCB 125um (5mil) STAND-OFF	959125
3	GLASS DIE 10x10mm	XXXXXX
3	GLASS DIE 12x12mm	XXXXXX
3	GLASS DIE 15x15mm	XXXXXX

BOARDS DELIVERED WITH GLASS DIE ATTACHED WITH CYANOACRYLATE GLUE GEL

GLOBAL FIDUCIAL

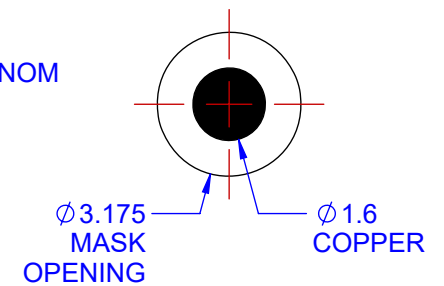

- NOTES: (UNLESS OTHERWISE SPECIFIED).
1. DIMENSIONS mm.
 2. STAND-OFF HEIGHT - SEE PART NUMBER TABLE.
 3. STAND-OFF MATERIAL: NON-COLLAPSIBLE POSTS.
 4. BOARD MATERIAL: FR4 WITH GREEN SOLDER MASK.
 5. BOARDS INCLUDE GLASS SLUGS (ASSEMBLED).
 6. SEE PAGE 9 FOR SPARE GLASS COMPONENTS.

TopLine®			
TITLE FLIP CHIP STAND-OFF BOARD CONTROLLED HEIGHT UNDERFILL			
SCALE 1:1	SIZE A	DRAWING NO. 959000	REV A
DO NOT SCALE DRAWING		SHEET 4 OF 9	

**MODEL
GLASS COMPONENTS SEATED ON BUMPS
AFTER MOUNTING TO BOARD**

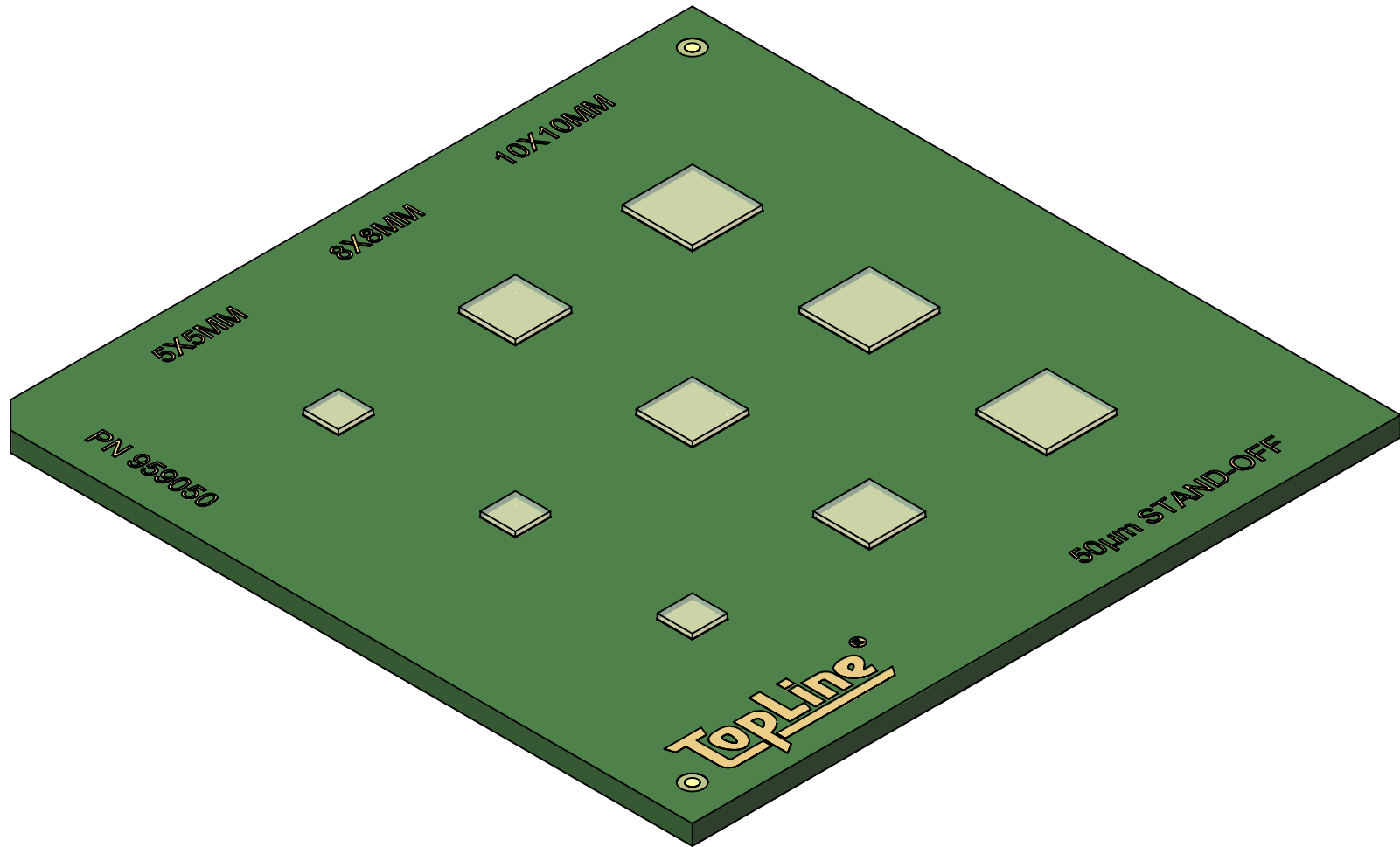

NOTES:

- 1) BOARDS DO NOT INCLUDE GLASS COMPONENTS
- 2) GLASS COMPONENTS ARE AVAILABLE SEPARATELY.
- 3) CUSTOMER TO MOUNT GLASS COMPONENTS ONTO BOARD PRIOR TO UNDERFILL.
- 4) SEE PAGE 9 FOR OPTIONAL THICKNESS GLASS COMPONENTS.

TopLine®			
TITLE FLIP CHIP STAND-OFF BOARD CONTROLLED HEIGHT UNDERFILL			
SCALE 3:2	SIZE A	DRAWING NO. 959000	REV A
DO NOT SCALE DRAWING		SHEET 5 OF 9	

**MODEL
DETAIL STAND-OFF
GLASS COMPONENT MOUNTED ON BUMPS
(BEFORE UNDERFILL)**

TOP VIEW

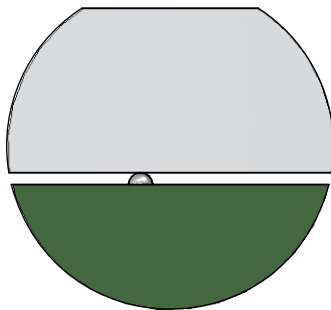
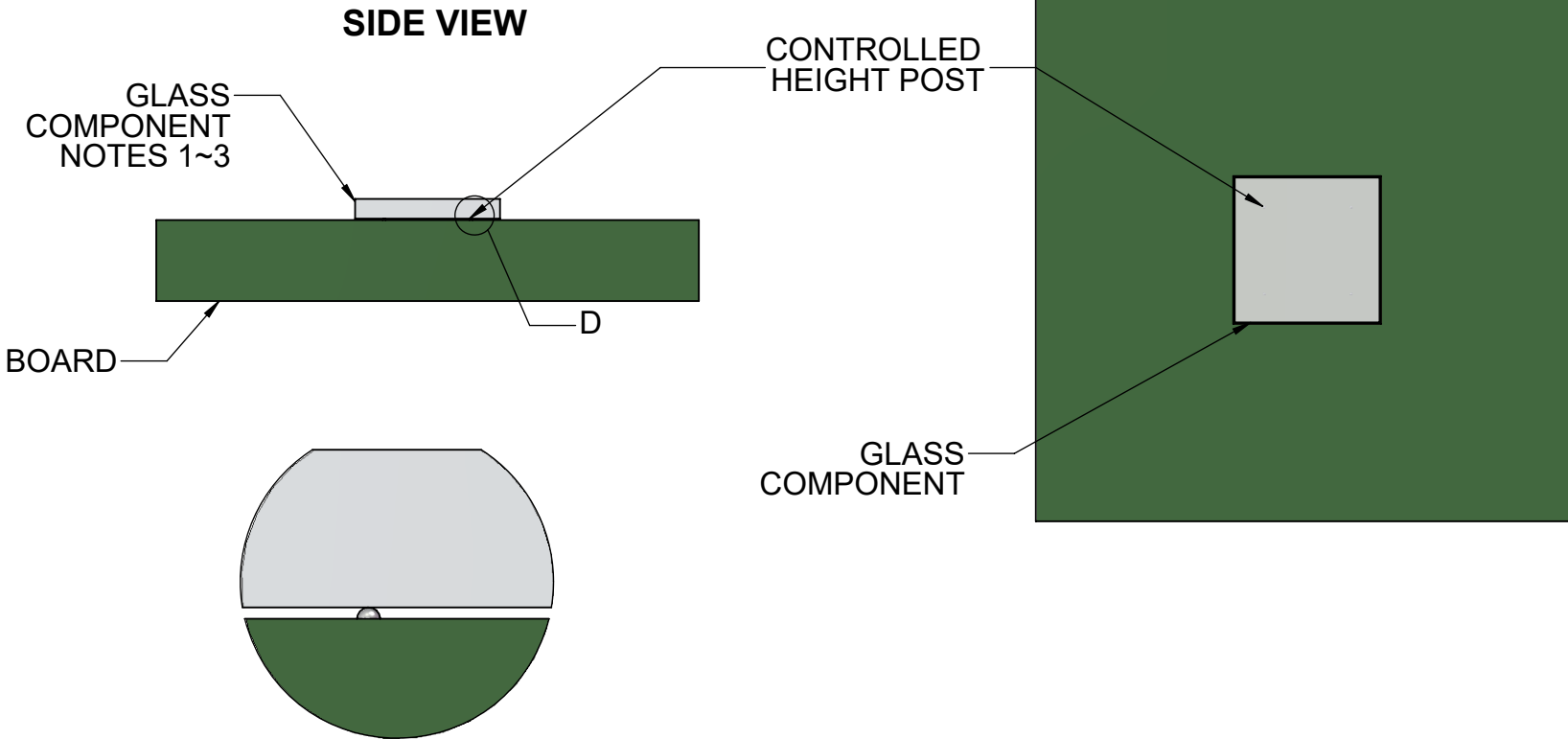

**DETAIL D
SCALE 32 : 1**

NOTES:

- 1) BOARDS DO NOT INCLUDE GLASS COMPONENTS
- 2) GLASS COMPONENTS ARE AVAILABLE SEPARATELY.
- 3) CUSTOMER TO MOUNT GLASS COMPONENTS ONTO BOARD PRIOR TO UNDERFILL.
- 4) SEE PAGE 9 FOR OPTIONAL THICKNESS GLASS COMPONENTS.

TopLine[®]			
TITLE FLIP CHIP STAND-OFF BOARD CONTROLLED HEIGHT UNDERFILL			
SCALE 4:1	SIZE A	DRAWING NO. 959000	REV A
DO NOT SCALE DRAWING		SHEET 6 OF 9	

**MODEL
JEDEC OUTLINE CARRIER TRAY
WITH FLIP CHIP STAND-OFF BOARDS
AND GLASS DIE ATTACHED**

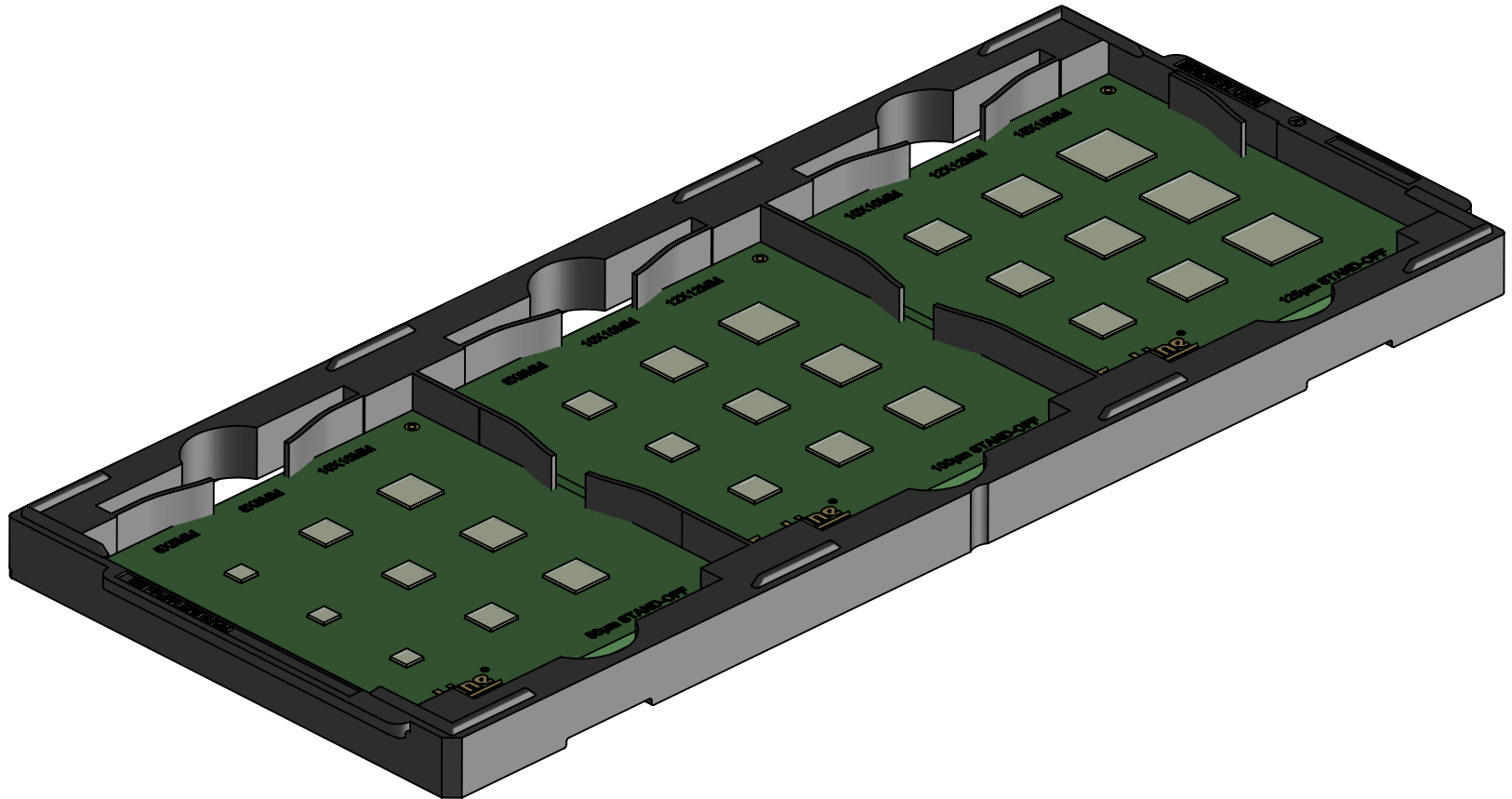

TopLine®

TITLE WP4-JIGTRAY-E
JEDEC OUTLINE CARRIER

SCALE 2:3	SIZE A	DRAWING NO. 959000	REV A
--------------	-----------	-----------------------	----------

DO NOT SCALE DRAWING

SHEET 7 OF 9

MODEL TOP VIEW

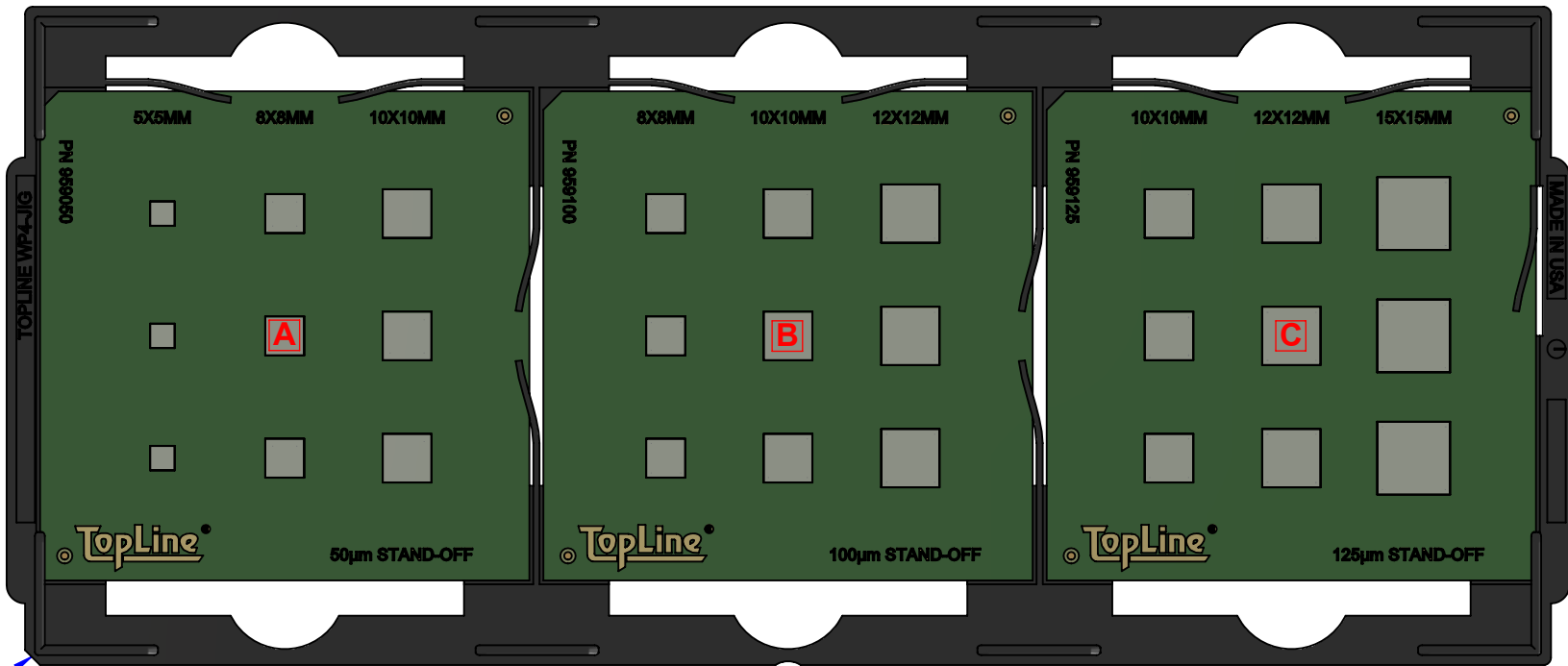

PIN 1 CHAMFER

DESCRIPTION OF ASSEMBLY

	STAND-OFF		GLASS DIE SIZE
A	50um	2 mils	5x5mm, 8x8mm, 10x10mm
B	100um	4 mils	8x8mm, 10x10mm, 12x12mm
C	125um	5 mils	10x10mm, 12x12m, 15x15mm

TopLine®

TITLE WP4-JIGTRAY-E
JEDEC OUTLINE CARRIER

SCALE 2:3	SIZE A	DRAWING NO. 959000	REV A
--------------	-----------	-----------------------	----------

DO NOT SCALE DRAWING

SHEET 8 OF 9

SPARE GLASS COMPONENTS WITHOUT BUMPS

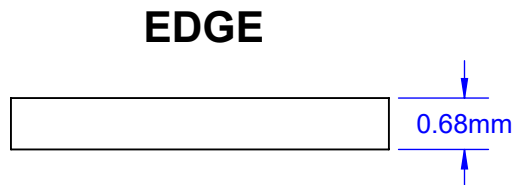
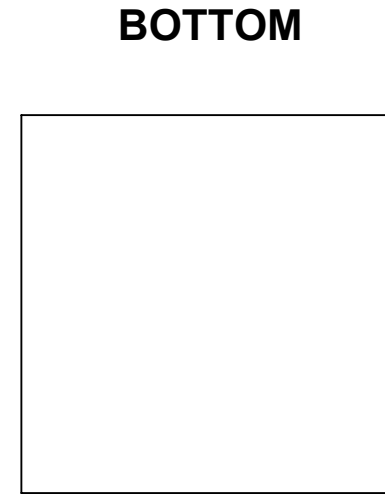
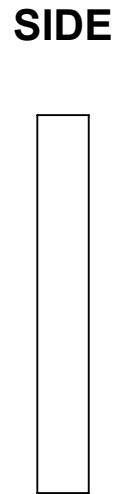
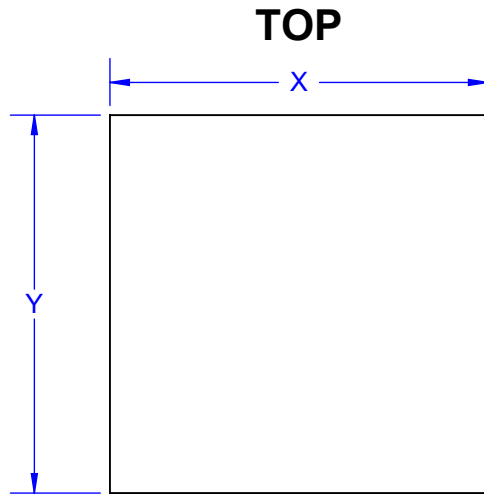

GLASS PART NUMBER TABLE			
X/Y SIZE	DESCRIPTION	QTY PER TRAY	GLASS PN
5x5mm	GD-5x5-BG680-W	36pcs	205056
8x8mm	GD-8x8-BG680-P	64pcs	208086
10x10mm	GD-10x10-BG680-P	49pcs	210106
12x12mm	GD-12x12-BG680-P	36pcs	212126
15x15mm	GC-15x15-BG680-P	25pcs	215156

- NOTES: (UNLESS OTHERWISE SPECIFIED).
1. DIMENSIONS: mm.
 2. COMPONENT MATERIAL: BOROSILICATE GLASS.
 3. BUMPS- NONE.
 4. STANDARD PACKAGING: WAFFLE PACK.

TopLine[®]			
TITLE FLIP CHIP STAND-OFF BOARD CONTROLLED HEIGHT UNDERFILL			
SCALE 10:1	SIZE A	DRAWING NO. 959000	REV A
DO NOT SCALE DRAWING		SHEET 9 OF 9	