

SIDE VIEW

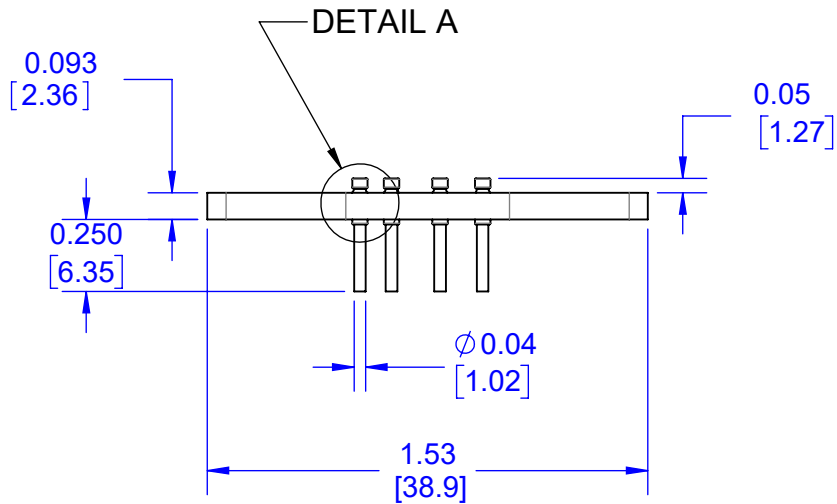

BOTTOM VIEW

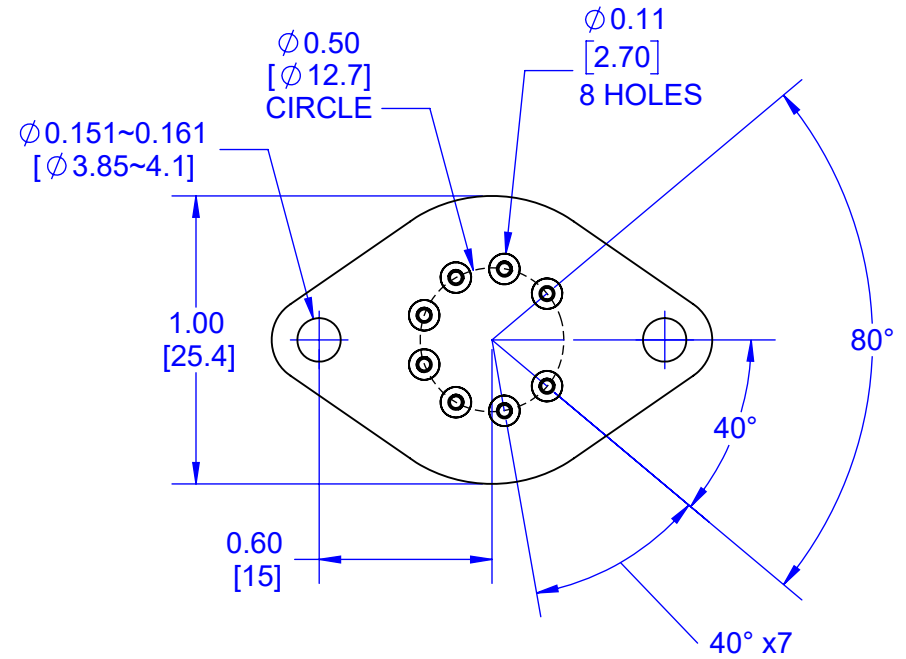

TOP VIEW

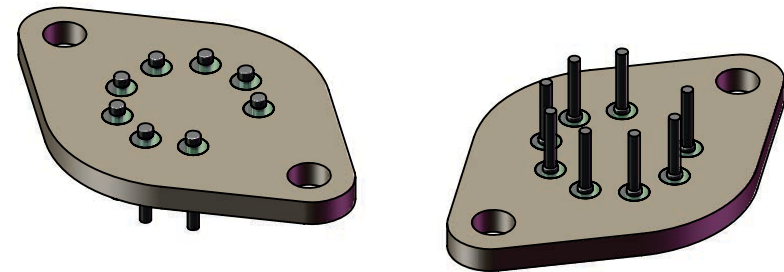
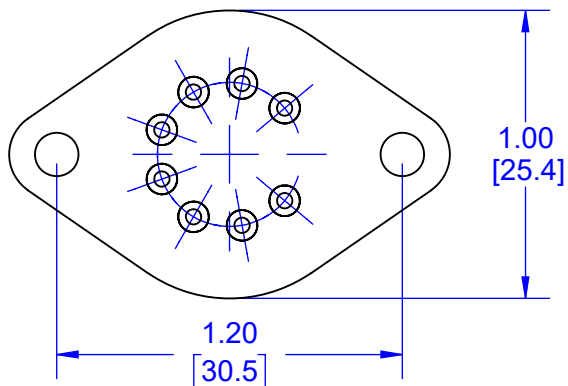

MODEL

NOTES:

1. DIMENSIONS INCH [mm].
2. PLATING: ELECTROLYTIC NICKEL 5.08µm (200 micro-inch).
3. LEADS: ALLOY 52.

APPROVALS	DATE	TopLine®			
DRAWN T.Au	3/23/2022				
ENG M. Hart	3/23/2022	TITLE TO3-8L NH HEADER			
MFG		SCALE 1.5:1	SIZE A	DRAWING NO. 103008	REV A
QA		DO NOT SCALE DRAWING			SHEET 1 OF 2
CUST					
REVISED					

NAIL-HEAD DETAIL A

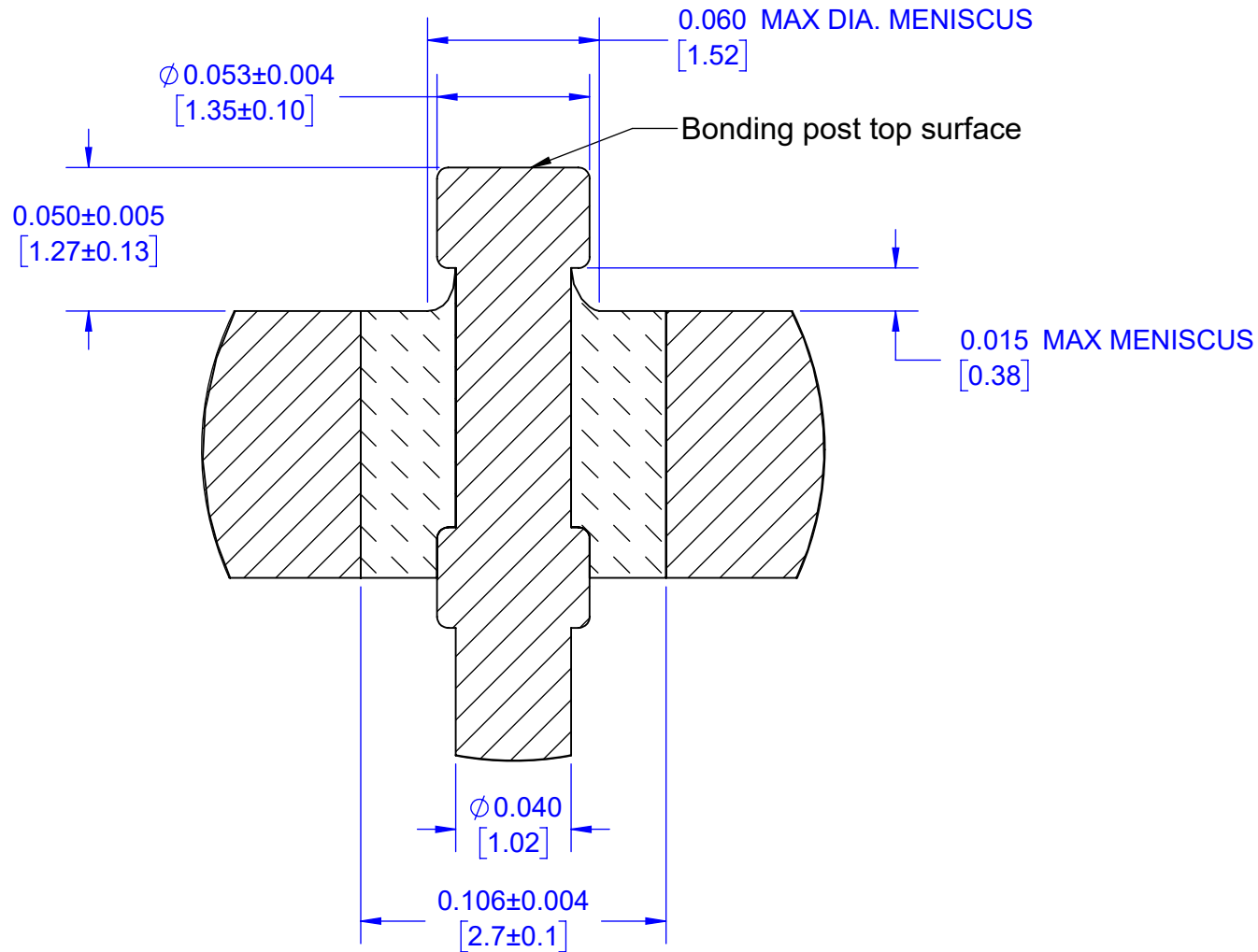

NOTES:

1. DIMENSIONS INCH [mm].
2. PLATING: ELECTROLYTIC NICKEL 5.08 μ m (200 micro-inch).
3. LEADS: ALLOY 52.

TopLine[®]			
TITLE		TO3-8L NH HEADER	
SCALE	SIZE	DRAWING NO.	REV
16:1	A	103008	A
DO NOT SCALE DRAWING			SHEET 2 OF 2