

CBGA WITH DIE

TOP VIEW

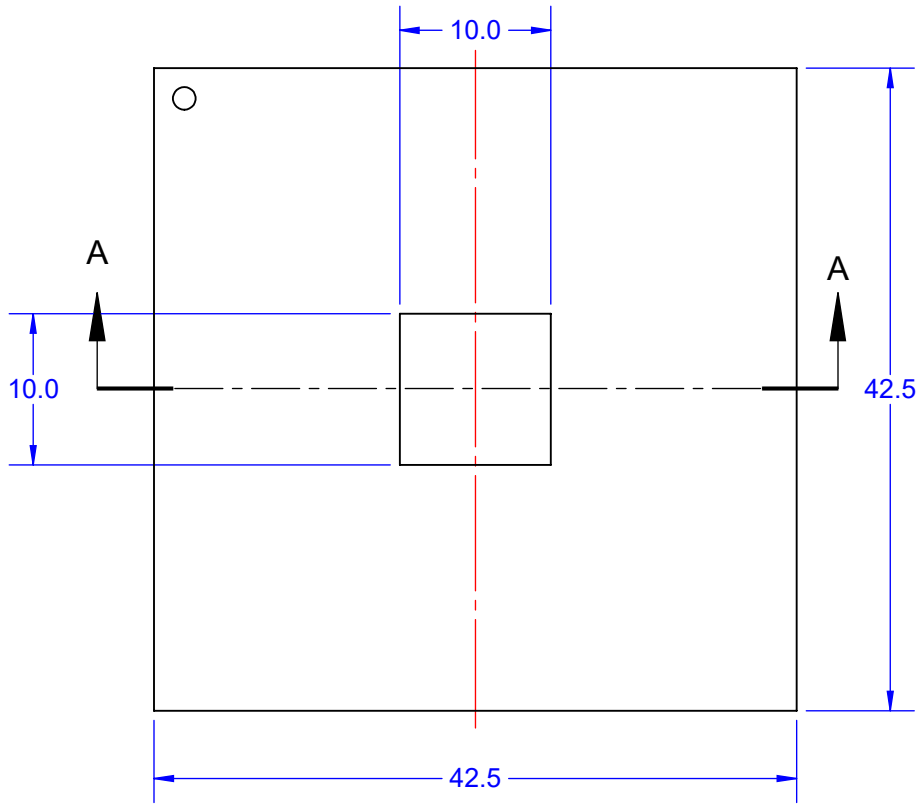

BALL VIEW

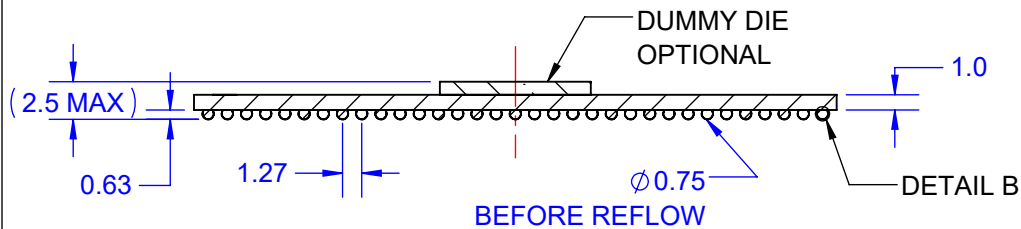
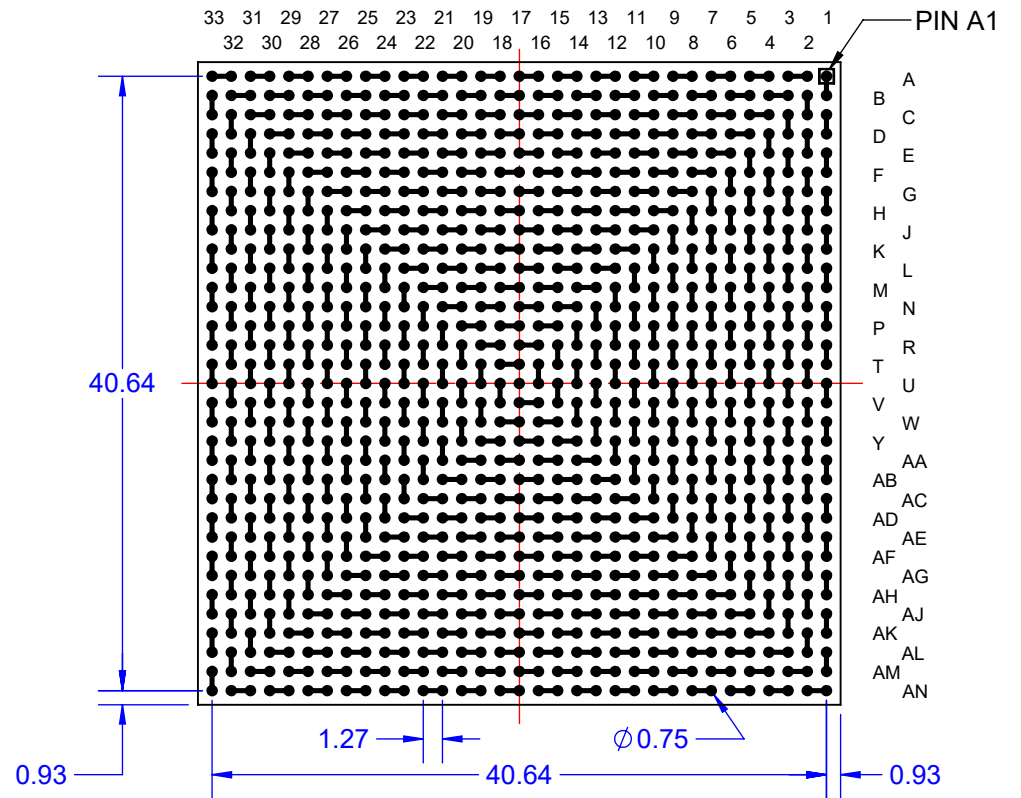

SECTION A-A
SCALE 2 : 1

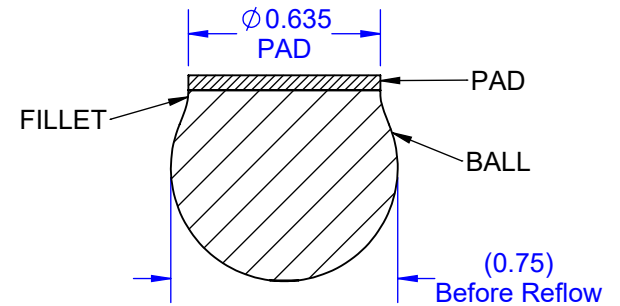

DETAIL B

Notes: (Unless Otherwise Specified).

- 1) DIMENSIONS MM.
- 2) SOLDER BALL ALLOY: SEE PART NUMBER CONFIGURATION.
- 3) BALL DIAMETER (BEFORE REFLOW): 0.76mm (30 MIL).
- 4) SOLDER MASK OPENING: 0.635mm (25 MIL).
- 5) SUBSTRATE: ALUMINA CERAMIC.

APPROVALS	DATE				
DRAWN T. Au	08/21/2022				
ENG M. Hart	08/21/2022	TITLE CBGA1089T1.27C-DC339 CERAMIC BALL GRID ARRAY			
MFG					
QA		SCALE 2:1	SIZE A	DRAWING NO. 523397	REV A
CUST		DO NOT SCALE DRAWING			SHEET 1 OF 7
REVISED					

TOP VIEW

CBGA WITHOUT DIE

BALL VIEW

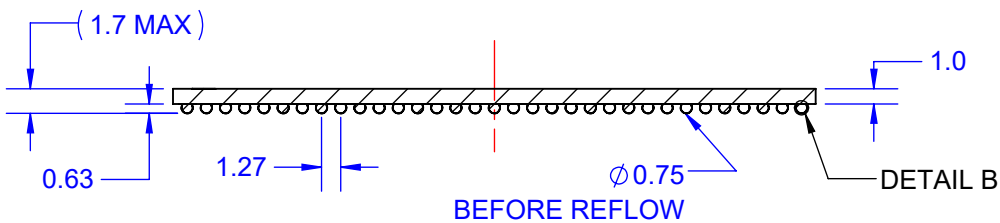
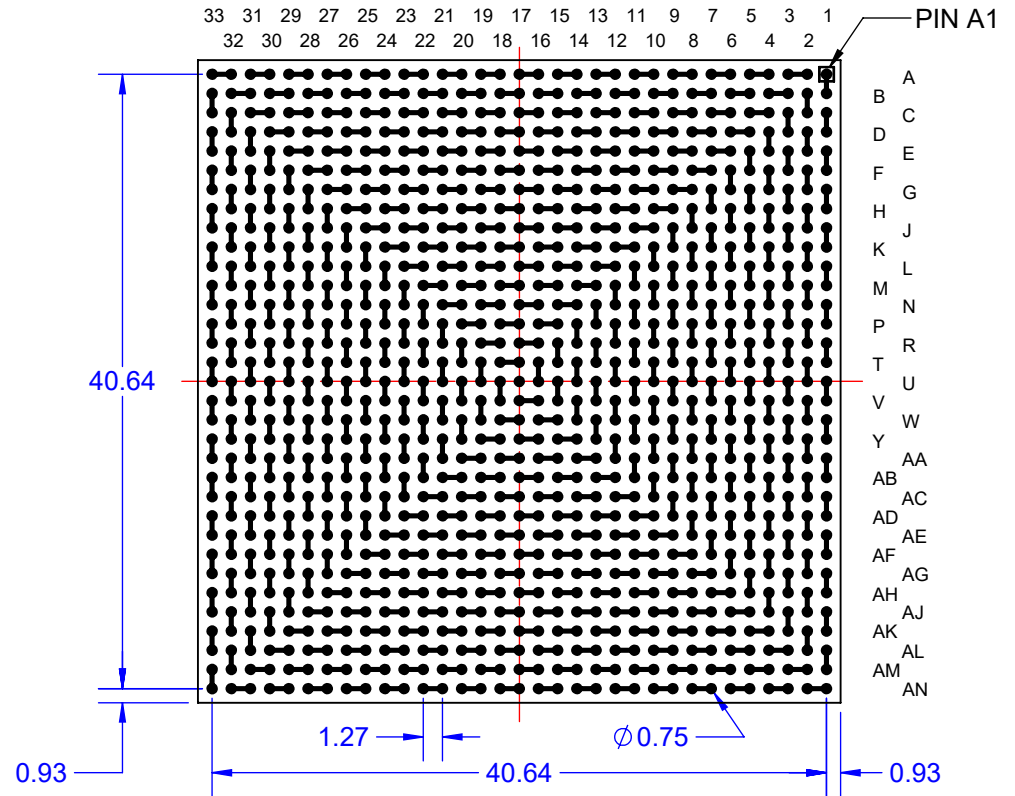
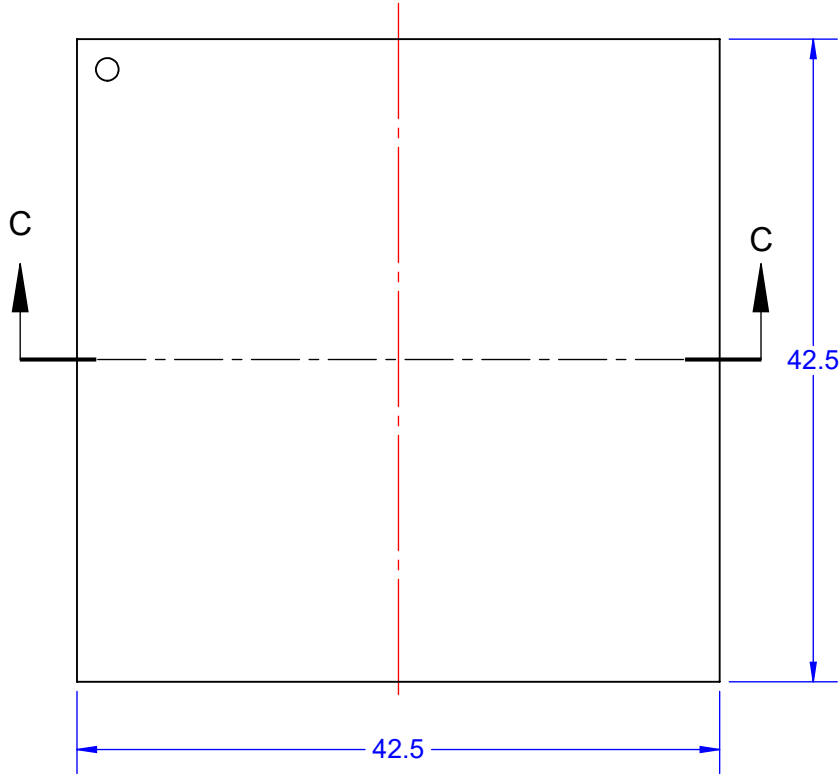

SECTION C-C
SCALE 2 : 1

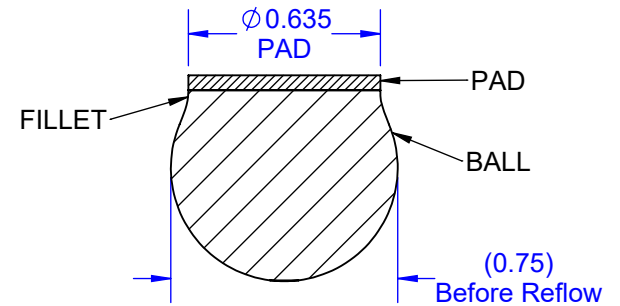

DETAIL B

Notes: (Unless Otherwise Specified).

- 1) DIMENSIONS MM.
- 2) SOLDER BALL ALLOY: SEE PART NUMBER CONFIGURATION.
- 3) BALL DIAMETER (BEFORE REFLOW): 0.76mm (30 MIL).
- 4) SOLDER MASK OPENING: 0.635mm (25 MIL).
- 5) SUBSTRATE: ALUMINA CERAMIC.

APPROVALS	DATE	TopLine [®]			
DRAWN T. Au	08/21/2022				
ENG M. Hart	08/21/2022	TITLE CBGA1089T1.27C-DC339 CERAMIC BALL GRID ARRAY			
MFG		SCALE	SIZE	DRAWING NO.	REV
QA		2:1	A	523397	A
CUST		DO NOT SCALE DRAWING			SHEET 2 OF 7
REVISED					

BALL VIEW

33 32 31 30 29 28 27 26 25 24 23 22 21 20 19 18 17 16 15 14 13 12 11 10 9 8 7 6 5 4 3 2 1

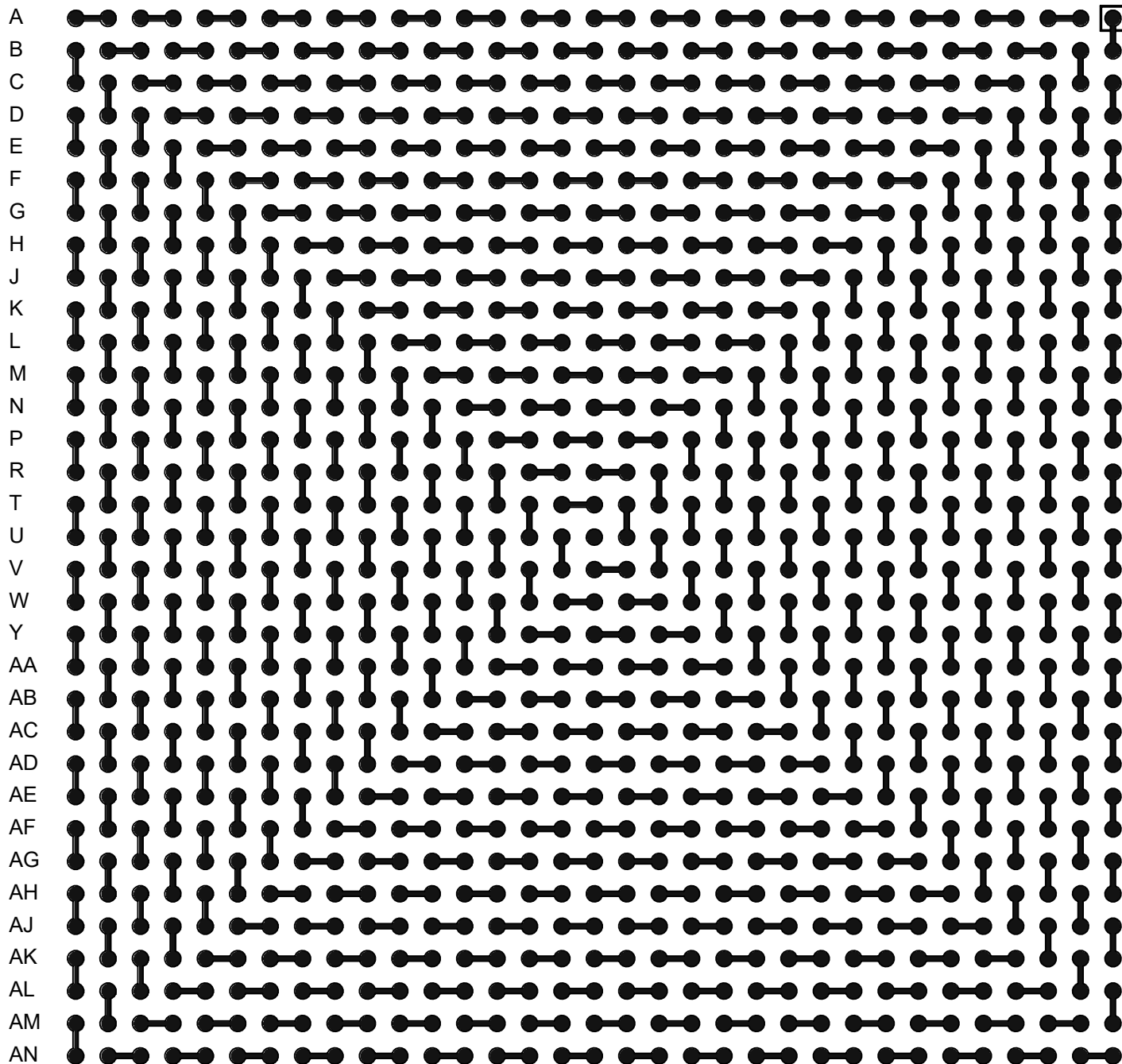

TopLine[®]			
TITLE CBGA1089T1.27C-DC339 CERAMIC BALL GRID ARRAY			
SCALE 4.25:1	SIZE A	DRAWING NO. 523397	REV A
DO NOT SCALE DRAWING		SHEET 3 OF 7	

BOTTOM SIDE (VIEWED FROM TOP)

1 2 3 4 5 6 7 8 9 10 11 12 13 14 15 16 17 18 19 20 21 22 23 24 25 26 27 28 29 30 31 32 33

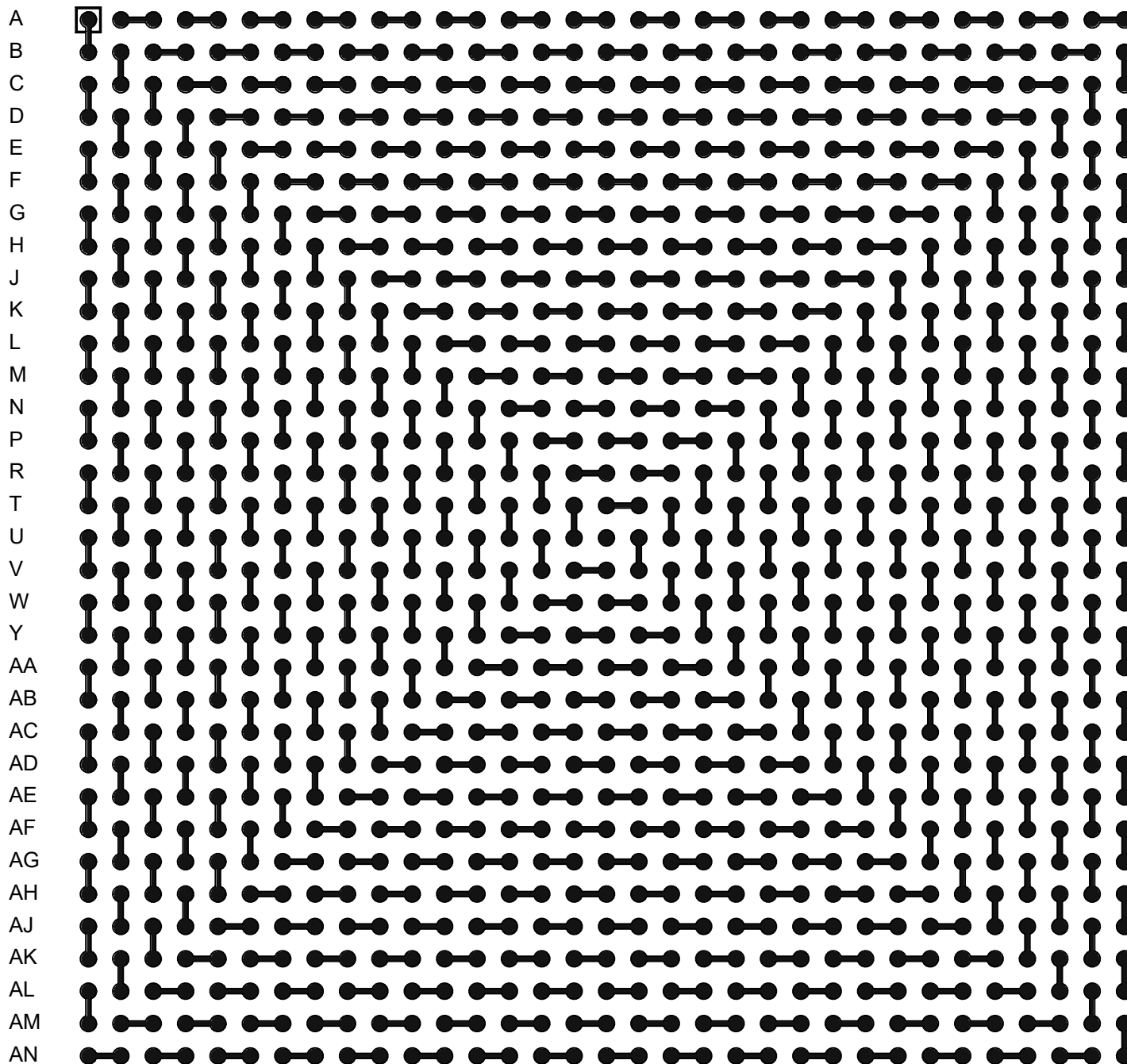

TopLine[®]			
TITLE CBGA1089T1.27C-DC339 CERAMIC BALL GRID ARRAY			
SCALE 4.25:1	SIZE A	DRAWING NO. 523397	REV A
DO NOT SCALE DRAWING			SHEET 4 OF 7

**MODEL
CBGA WITH BALL
WITHOUT DIE**

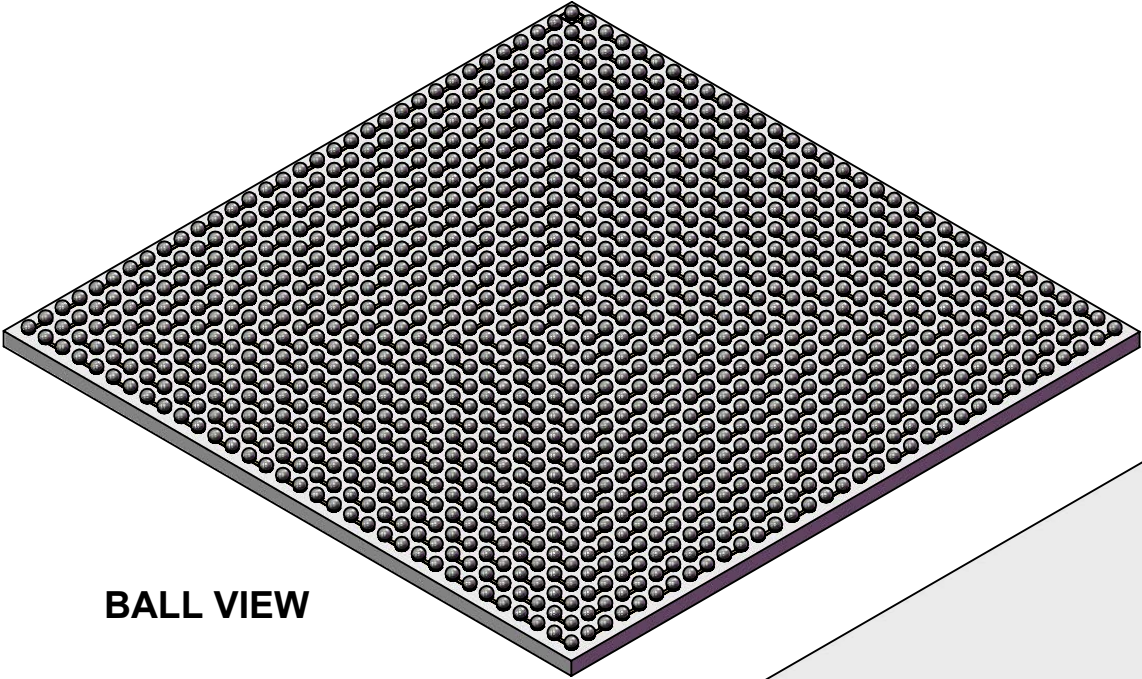

BALL VIEW

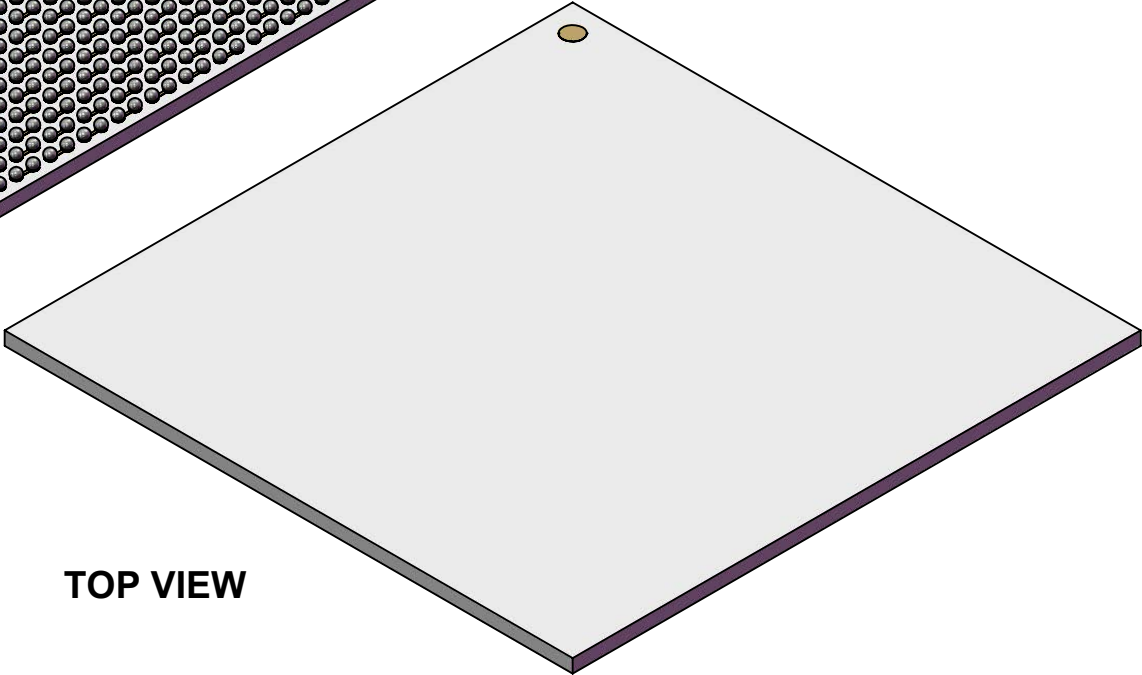

TOP VIEW

TopLine[®]			
TITLE CBGA1089T1.27C-DC339 CERAMIC BALL GRID ARRAY			
SCALE	SIZE	DRAWING NO.	REV
2.5:1	A	523397	A
DO NOT SCALE DRAWING			SHEET 5 OF 7

**MODEL
CBGA WITH BALL
WITH DIE**

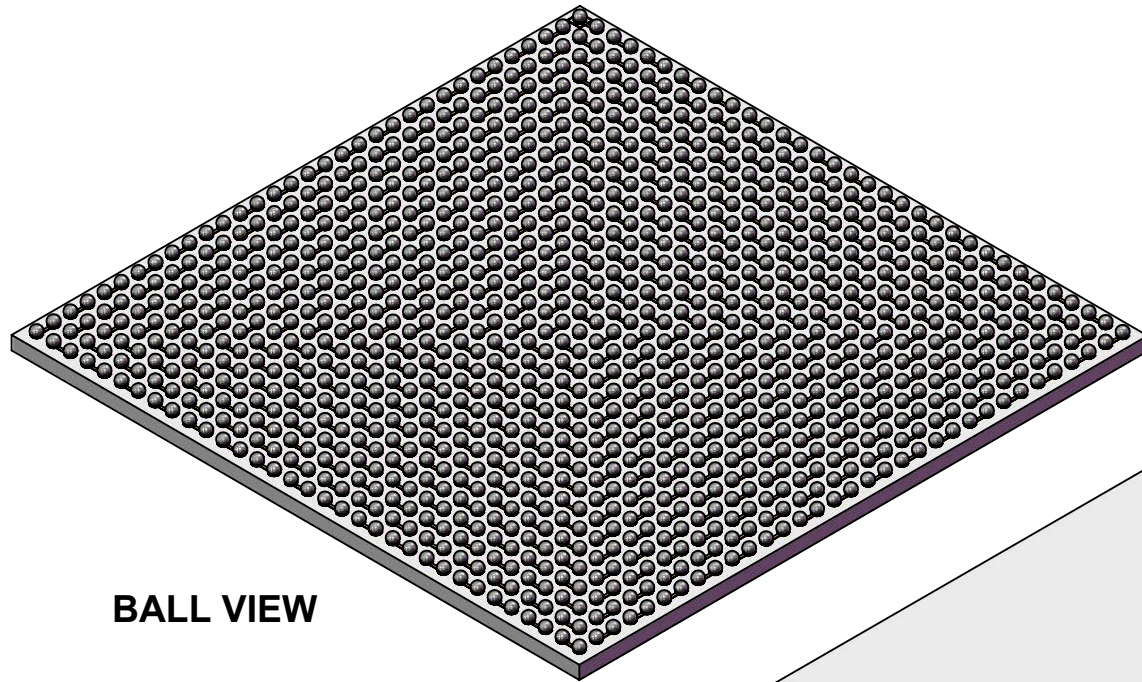

BALL VIEW

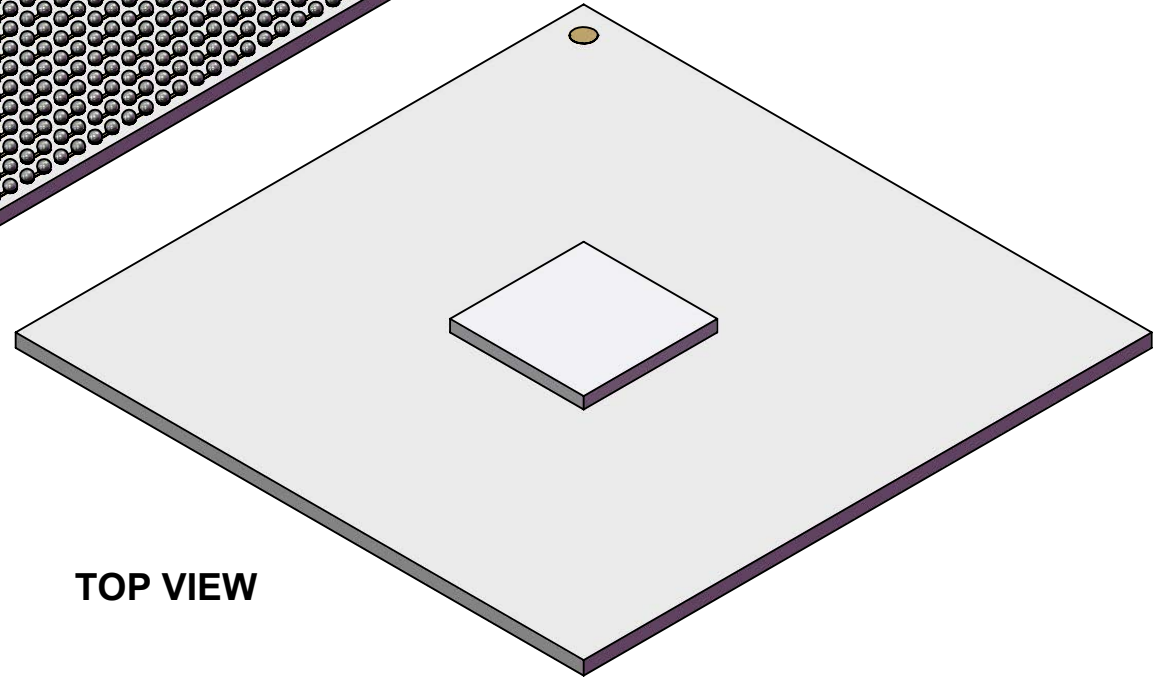

TOP VIEW

TopLine[®]

TITLE CBGA1089T1.27C-DC339
 CERAMIC BALL GRID ARRAY

SCALE	SIZE	DRAWING NO.	REV
2.5:1	A	523397	A

DO NOT SCALE DRAWING

SHEET 6 OF 7

PART NUMBER SYSTEM

CBGA

1089

T

1.27

C

DC339

D

SERIES

CBGA = CERAMIC
BALL GRID ARRAY

BALLS

NBR SOLDER
BALLS

TRAY

T = JEDEC

PITCH

1.27mm = 0.050"

ALLOY

L = Sn62/Pb36/Ag2.0*
X = Sn63/Pb37*
C = SAC305*
Blank = Sn10/Pb90

DIE

D = DUMMY DIE
BLANK = WITHOUT DIE

DAISY CHAIN

DC339 = SEE PATTERN

PART NUMBER	BALL ALLOY	CODE	LEAD FREE	DIE
CBGA1089T1.27-DC339	Sn10/Pb90	Sn10	NO	NO
CBGA1089T1.27-DC339D	Sn10/Pb90	Sn10	NO	YES
CBGA1089T1.27L-DC339	Sn62/Pb36/Ag2.0	Sn62	NO	NO
CBGA1089T1.27L-DC339D	Sn62/Pb36/Ag2.0	Sn62	NO	YES
CBGA1089T1.27X-DC339	Sn63/Pb37	Sn63	NO	NO
CBGA1089T1.27X-DC339D	Sn63/Pb37	Sn63	NO	YES
CBGA1089T1.27C-DC339	Sn96.5/Ag3.0/Cu0.5	SAC305	YES	NO
CBGA1089T1.27C-DC339D	Sn96.5/Ag3.0/Cu0.5	SAC305	YES	YES

* THESE BALL ALLOYS NOT RECOMMENDED FOR
MOUNTING ON FR4 BOARDS DUE TO CTE MISMATCH

TopLine[®]

TITLE CBGA1089T1.27C-DC339
CERAMIC BALL GRID ARRAY

SCALE NONE	SIZE A	DRAWING NO. 523397	REV A
---------------	-----------	-----------------------	----------

DO NOT SCALE DRAWING

SHEET 7 OF 7