

BOTTOM VIEW

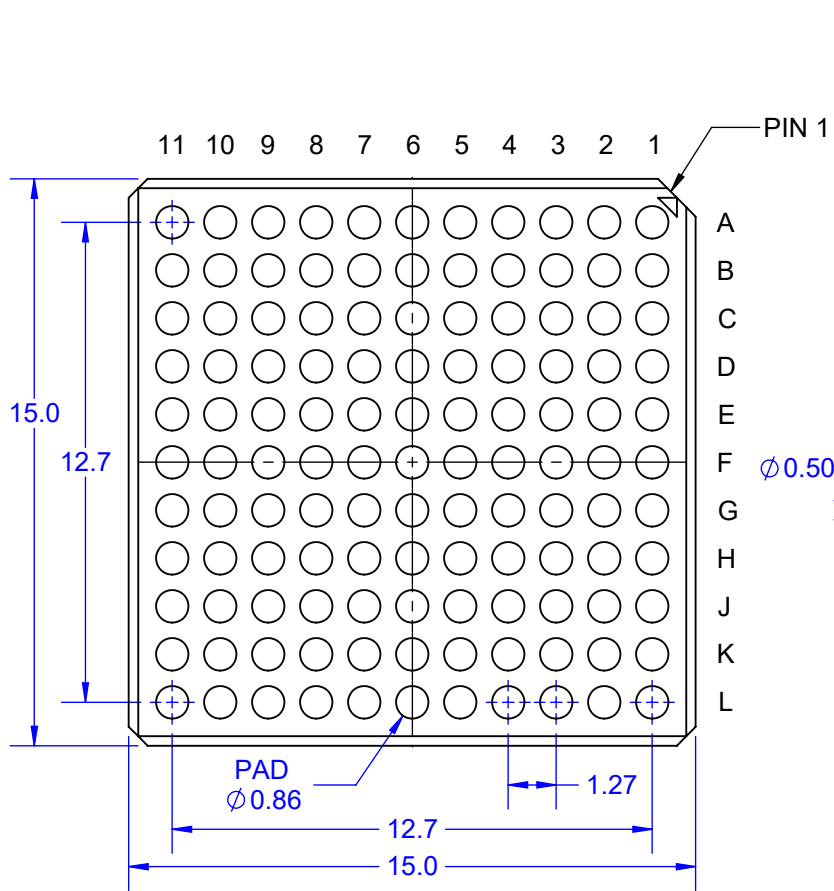

SIDE VIEW

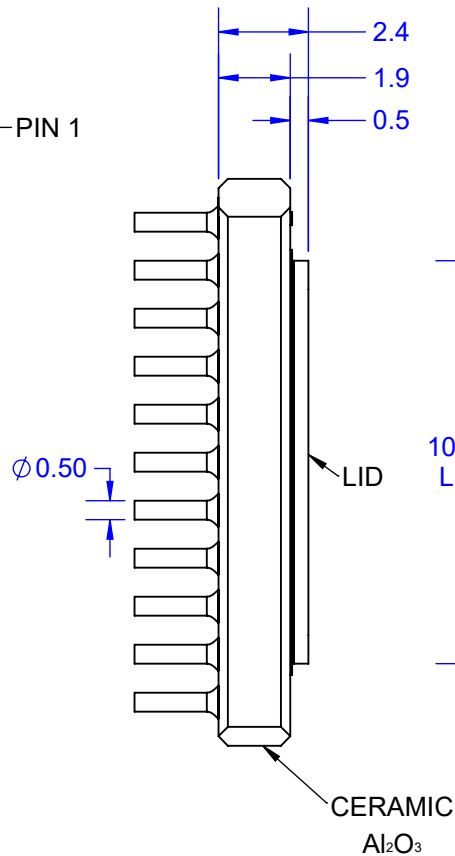

TOP VIEW

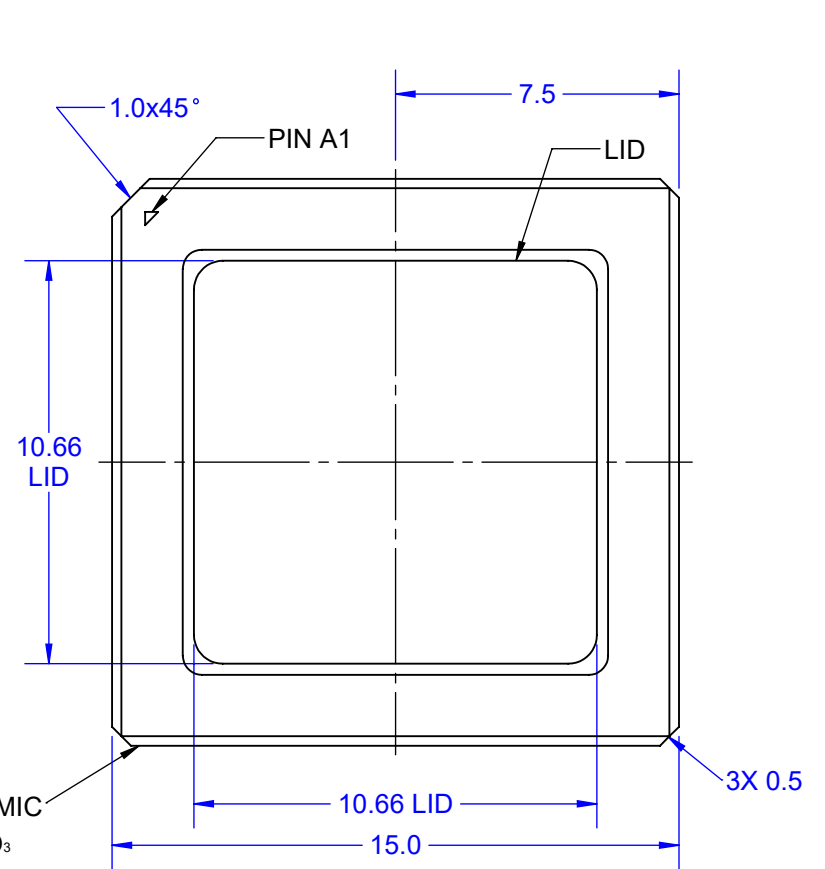

**Pb90/Sn10
PLAIN COLUMNS**

- NOTES:
 1. MATERIAL IS 90%-MINIMUM ALUMINA.
 2. UNITS ARE MILLIMETERS.

- Notes: (Unless Otherwise Specified).
 1) DIMENSIONS ARE IN mm.
 2) SHOWN WITH COLUMNS.
 3) SHOWN WITH LID COVER ATTACHED.
 4) PART NUMBER: CCGA121T1.27A.

PART NUMBER OPTIONS			
PART NUMBER	DIE	SOLDER PIN	LID
CCGA121T1.27A	YES	YES	YES

APPROVALS	DATE	TopLine®			
DRAWN T. Au	6/28/2022				
ENG M. Hart	6/28/2022	TITLE CCGA121T1.27A COLUMN GRID ARRAY			
MFG		SCALE 3:1	SIZE A	DRAWING NO. 160305	REV A
QA		DO NOT SCALE DRAWING			SHEET 1 OF 7
CUST					
REVISED					

BOTTOM VIEW

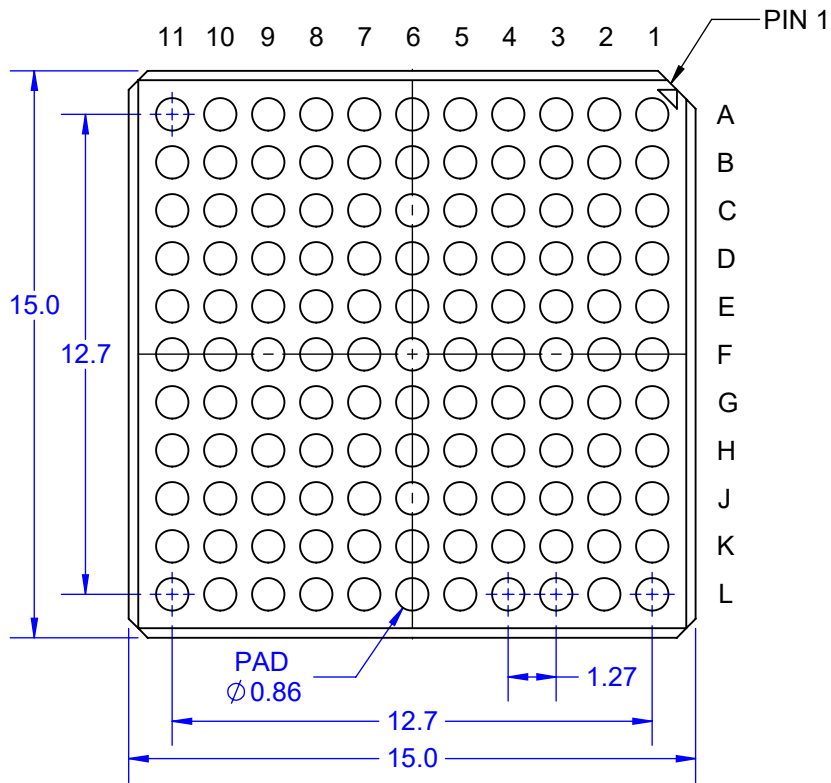

SIDE VIEW

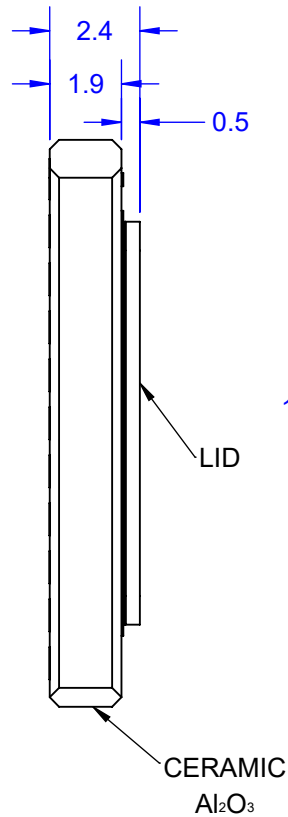

TOP VIEW

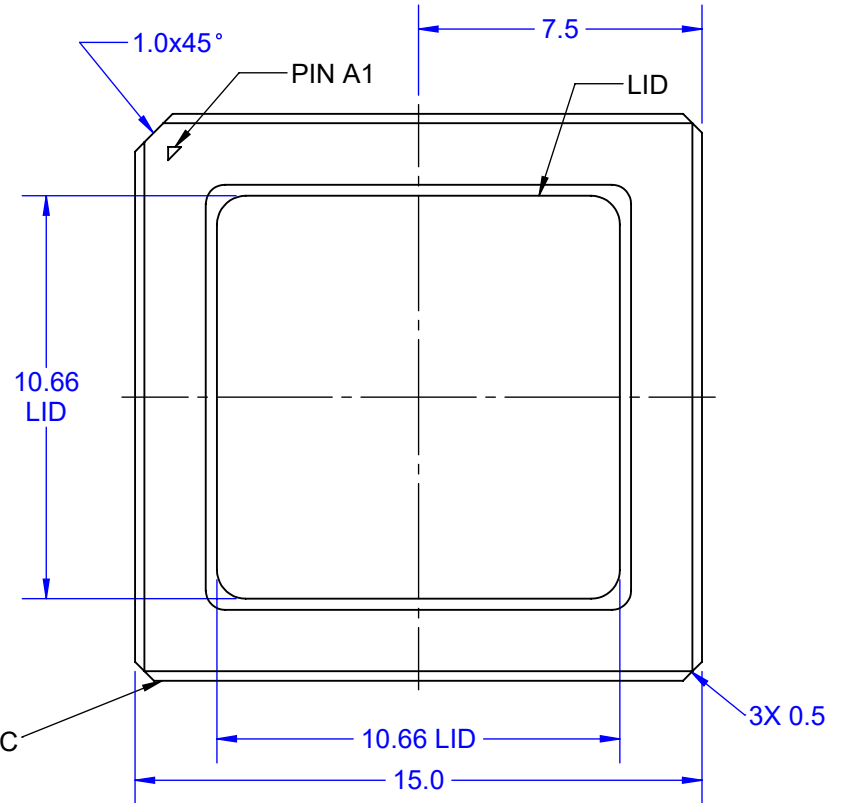

NOTES:

1. MATERIAL IS 90%-MINIMUM ALUMINA.
2. UNITS ARE MILLIMETERS.
3. EXPOSED-METAL PLATING PER MIL-PRF-38535.
 - a. NICKEL BASE: ELECTRO-PLATED 2.54~8.89µm.
 - b. GOLD: ELECTRO-PLATED 2.54~5.72µm.

Notes: (Unless Otherwise Specified).

- 1) DIMENSIONS ARE IN mm.
- 2) SHOWN WITHOUT COLUMNS.
- 3) SHOWN WITH LID COVER ATTACHED.
- 4) PART NUMBER: CLGA121T1.27.

PART NUMBER OPTIONS			
PART NUMBER	DIE	SOLDER PIN	LID
CLGA121T1.27	YES	NO	YES

APPROVALS	DATE	TopLine®			
DRAWN T. Au	6/28/2022				
ENG M. Hart	6/28/2022	TITLE CCGA121T1.27A COLUMN GRID ARRAY			
MFG		SCALE	SIZE	DRAWING NO.	REV
QA		3:1	A	160305	A
CUST		DO NOT SCALE DRAWING			SHEET 2 OF 7
REVISED					

PAD PATTERN

COLUMN (BALL) VIEW

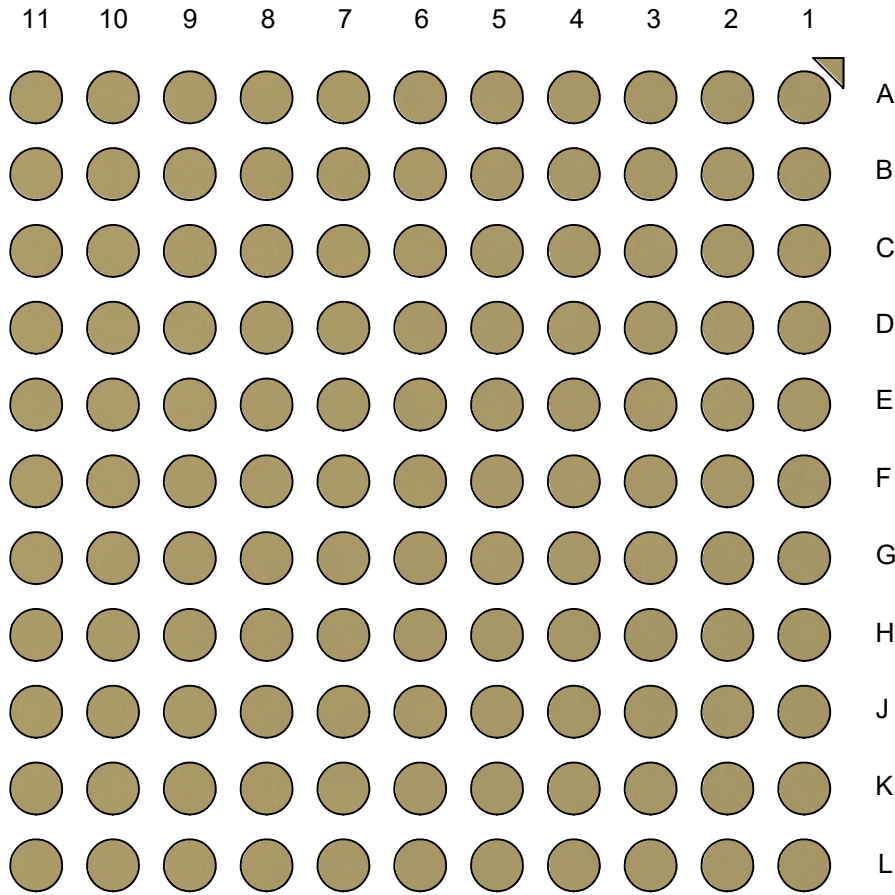

BOTTOM X-RAY VIEWED FROM TOP

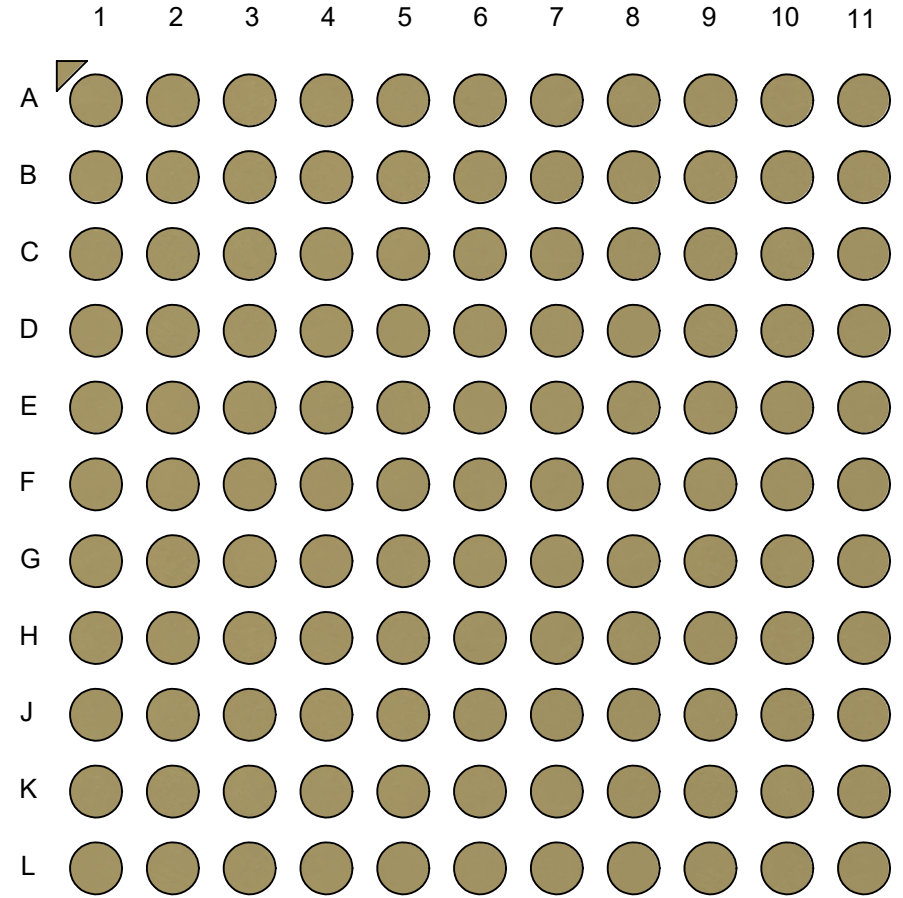

TopLine®

TITLE CCGA121T1.27A
COLUMN GRID ARRAY

SCALE 8:1	SIZE A	DRAWING NO. 160019	REV A
--------------	-----------	-----------------------	----------

DO NOT SCALE DRAWING

SHEET 3 OF 7

SOLDER PIN OPTIONS

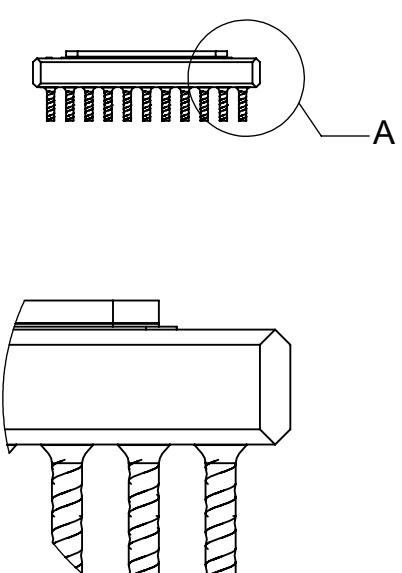

DETAIL A
SCALE 8 : 1

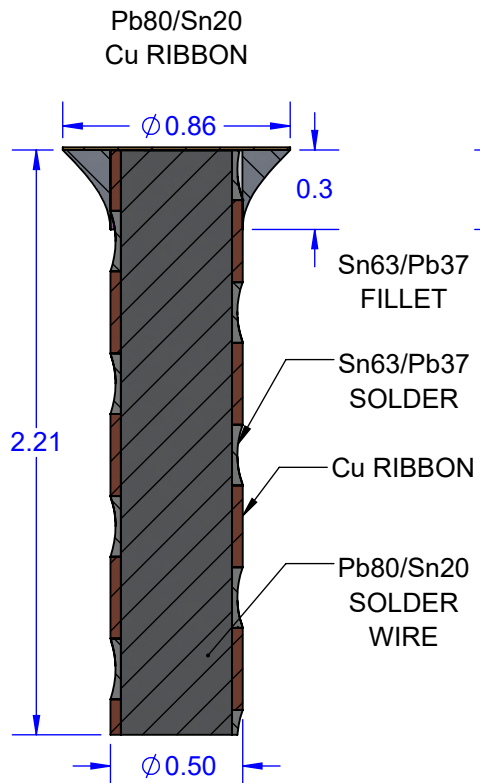

SECTION B-B
SCALE 35 : 1

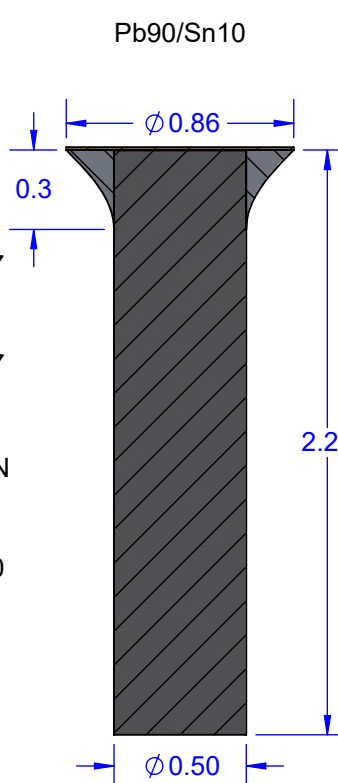

SECTION C-C
SCALE 35 : 1

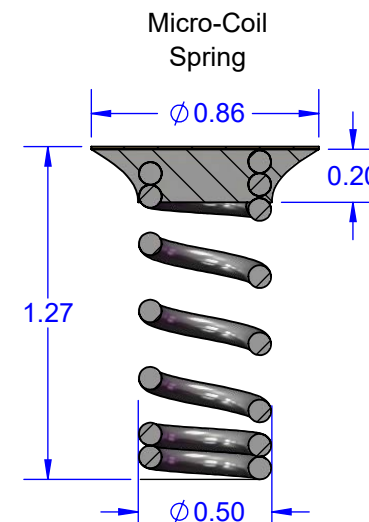

SECTION D-D
SCALE 35 : 1



Pb80/Sn20
Cu RIBBON
SCALE 15:1



Pb90/Sn10
SCALE 15:1



Micro-Coil
Spring
SCALE 20:1

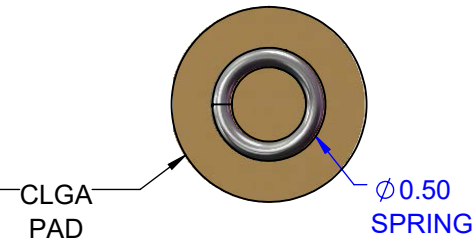
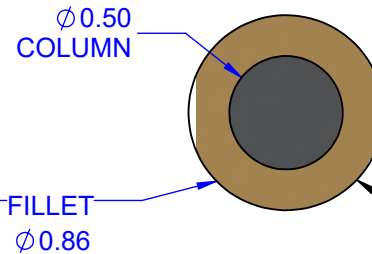
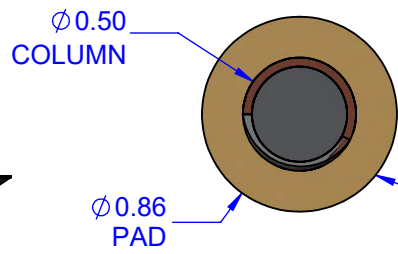

TopLine®			
TITLE CCGA121T1.27A COLUMN GRID ARRAY			
SCALE 8:1	SIZE A	DRAWING NO. 160305	REV A
DO NOT SCALE DRAWING			SHEET 4 OF 7

**MODEL
CCGA121T1.27A
Pb90/Sn10 PLAIN COLUMNS**

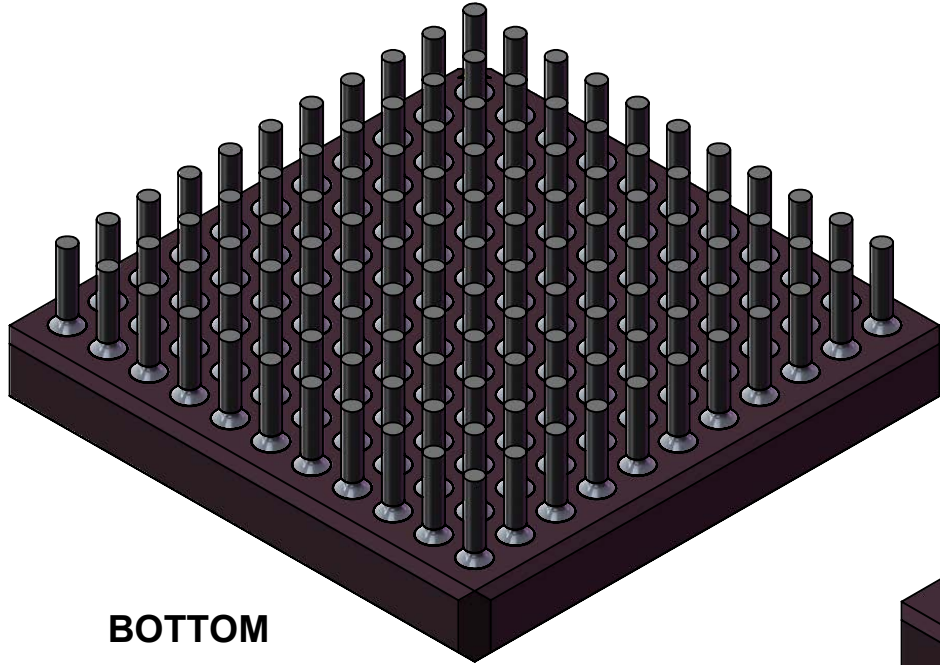

BOTTOM

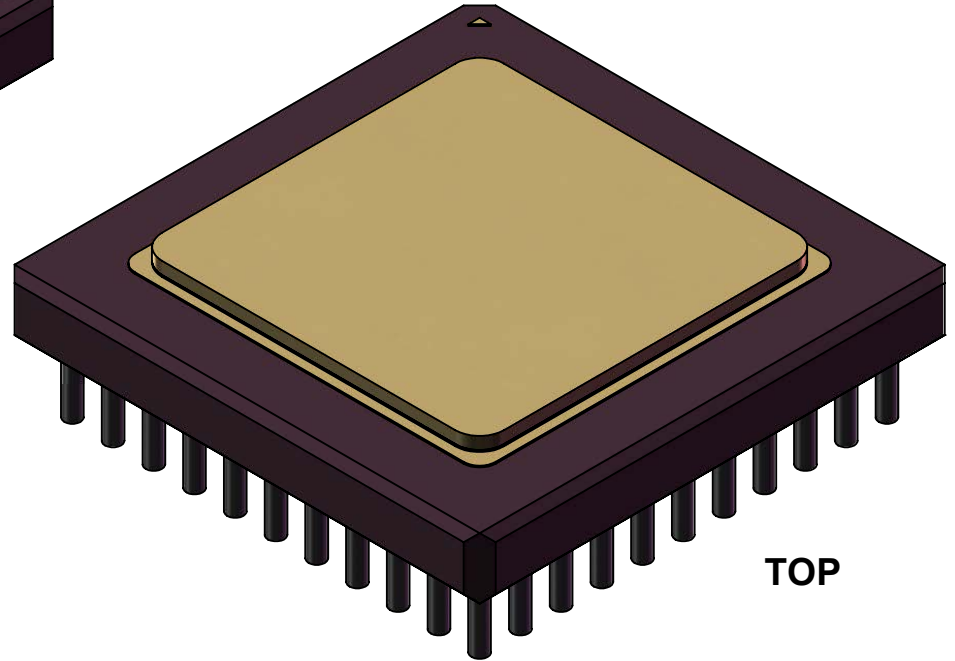

TOP

TopLine®			
TITLE		CCGA121T1.27A COLUMN GRID ARRAY	
SCALE	SIZE	DRAWING NO.	REV
6:1	A	160305	A
DO NOT SCALE DRAWING			SHEET 5 OF 7

**MODEL
CLGA121T1.27
WITHOUT COLUMNS**

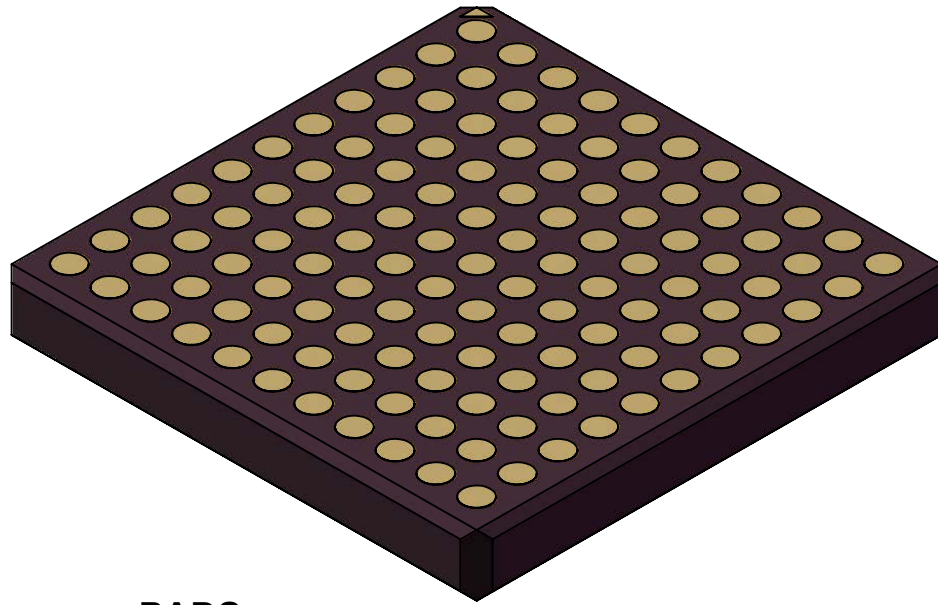

**PADS
(BOTTOM)**

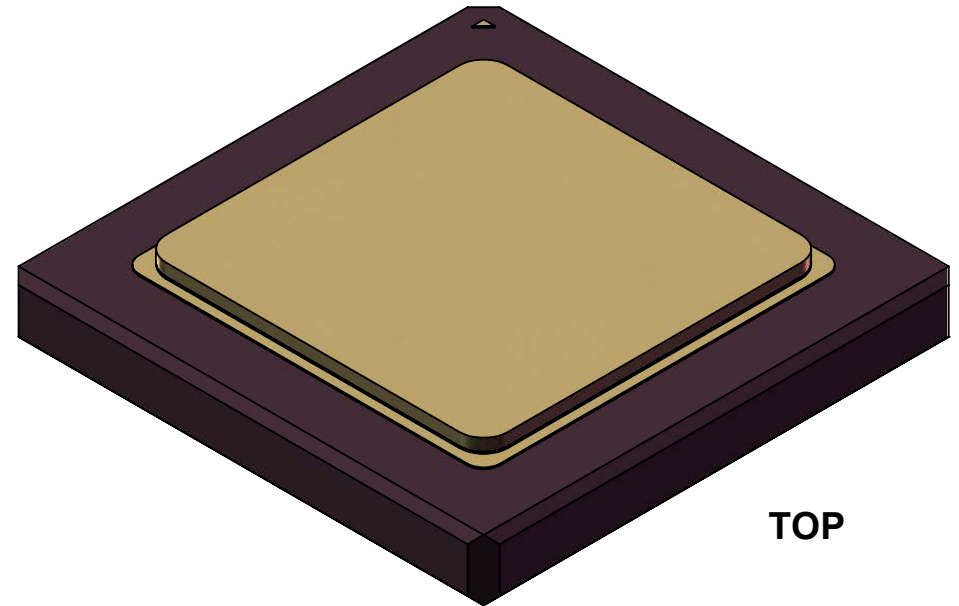

TOP

TopLine[®]			
TITLE		CCGA121T1.27A COLUMN GRID ARRAY	
SCALE	SIZE	DRAWING NO.	REV
6:1	A	160305	A
DO NOT SCALE DRAWING			SHEET 6 OF 7

EXPLODED VIEW CCGA TRAY BOX SYSTEM 1.27mm PITCH

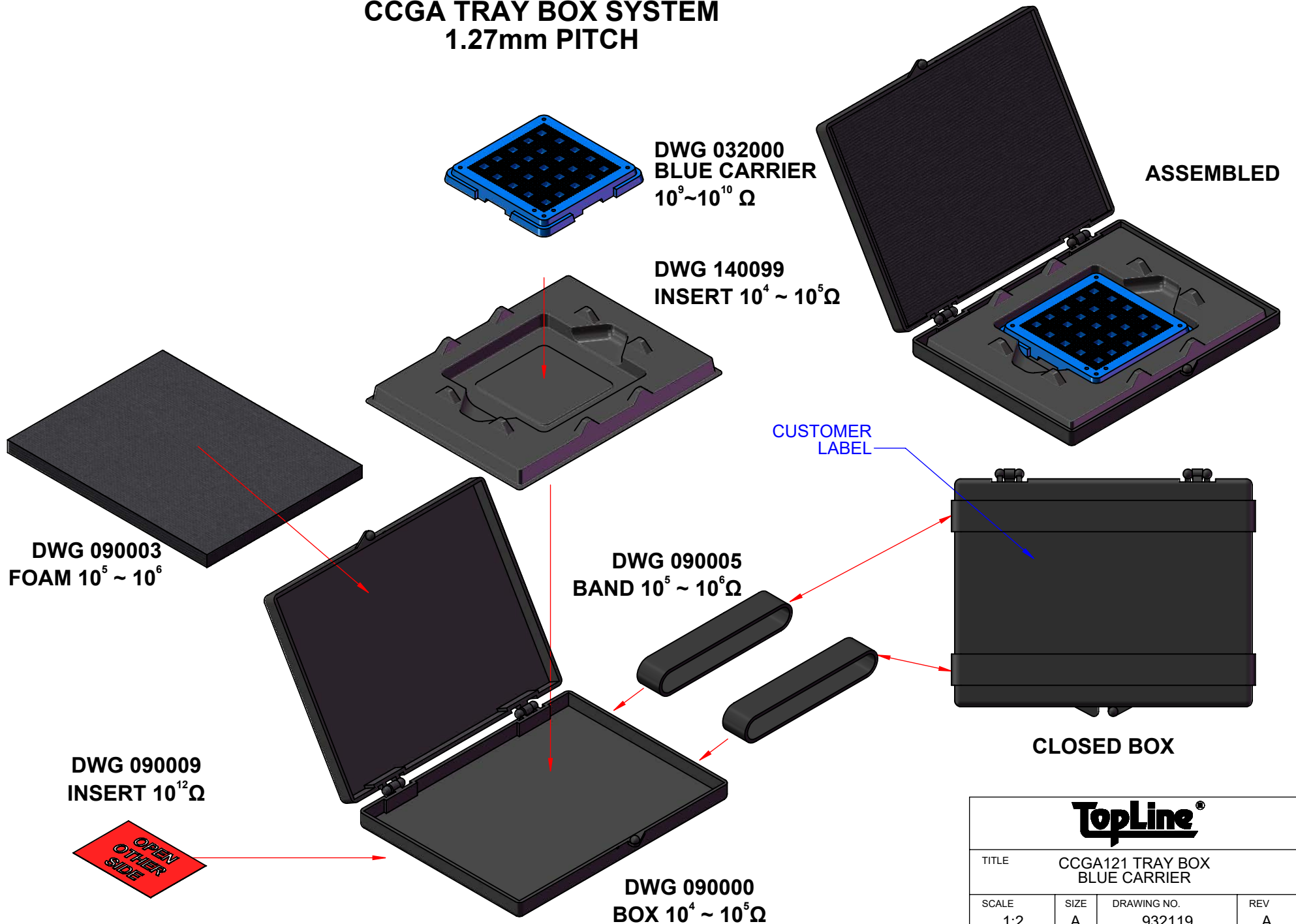

TopLine®			
TITLE		CCGA121 TRAY BOX BLUE CARRIER	
SCALE	SIZE	DRAWING NO.	REV
1:2	A	932119	A
DO NOT SCALE DRAWING			SHEET 7 OF 7