

TOP

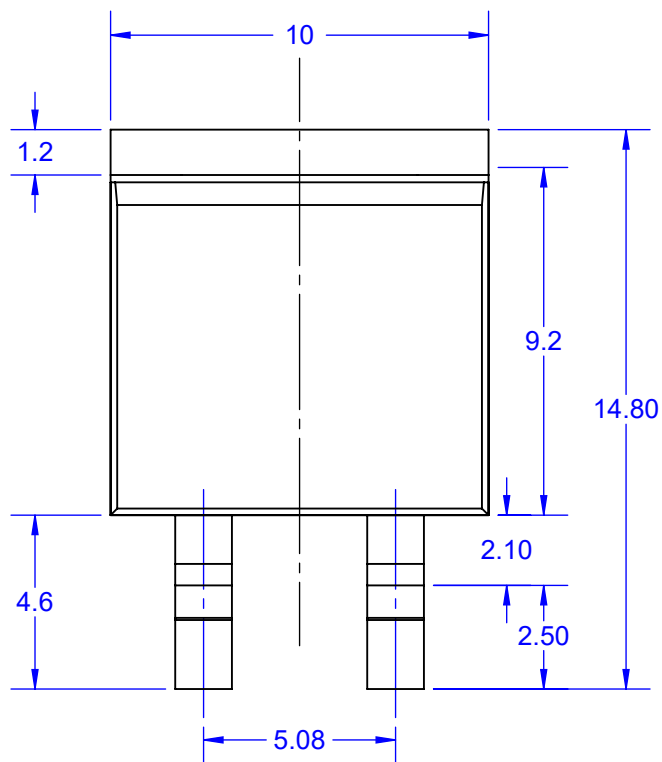

SIDE

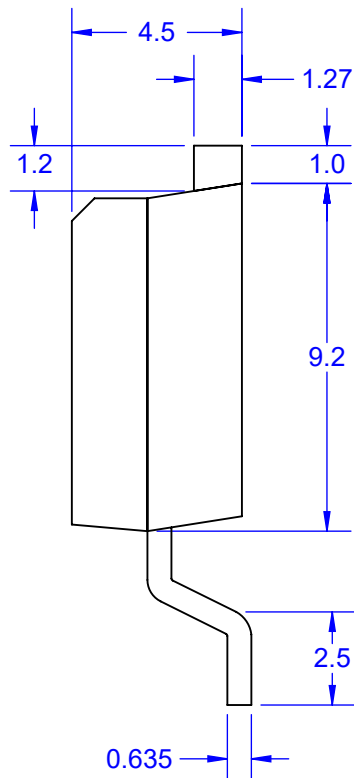

BOTTOM

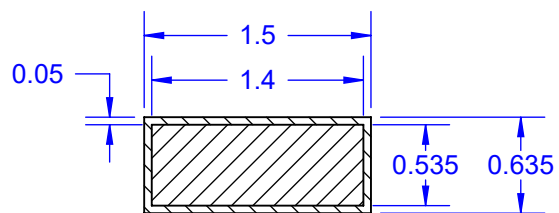
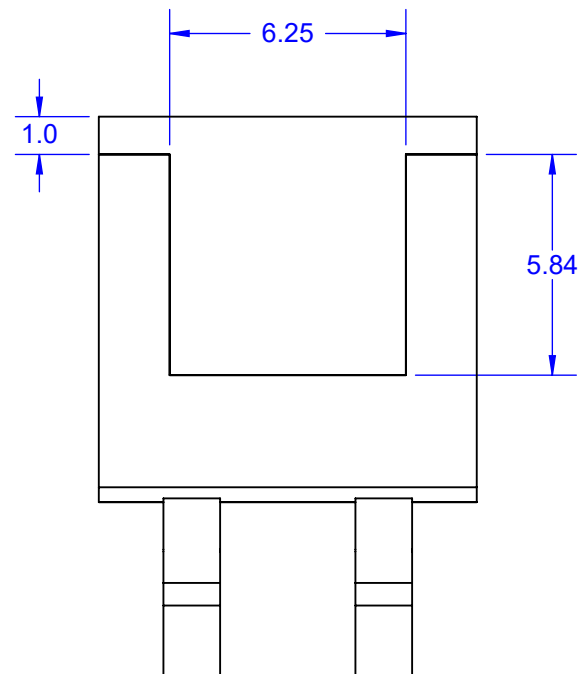

**END VIEW
TERMINAL**

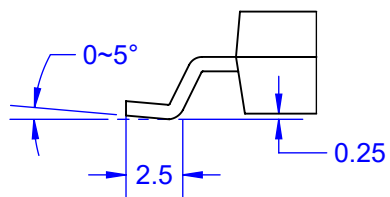

TOP

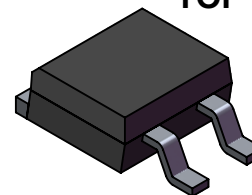

BOTTOM

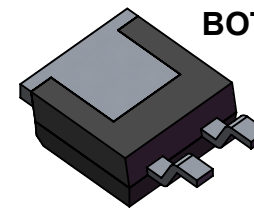

Notes: (Unless Otherwise Specified).

- 1) DIMENSIONS IN mm.
- 2) SEE DAISY CHAIN JUMPER DIAGRAMS (PAGE 2).
- 3) SEE PART NUMBER CONFIGURATION (PAGE 4).
- 4) RECOMMENDED PC BOARD LAYOUT PATTERN (PAGE 5).

APPROVALS	DATE	TopLine®			
DRAWN T.Au	02/21/16				
ENG M. Hart	02/21/16	TITLE D2PAK-DC123 JUMPER			
MFG		SCALE	SIZE	DRAWING NO.	REV
QA		5:1	A	158604	A
CUST		DO NOT SCALE DRAWING			SHEET 1 OF 6
REVISED					

**INTERNAL WIRING CIRCUIT (JUMPER)
DAISY CHAIN PART NUMBER SUFFIX
TOP VIEW**

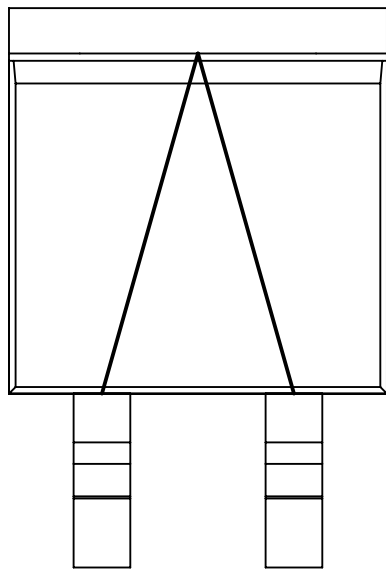

DC123
JUMPER

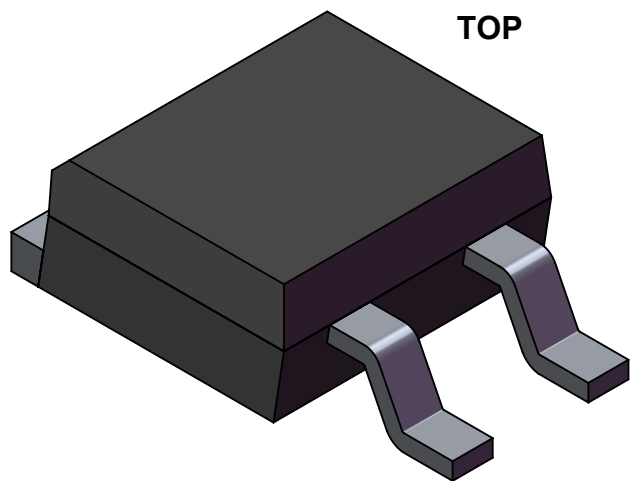

TOP

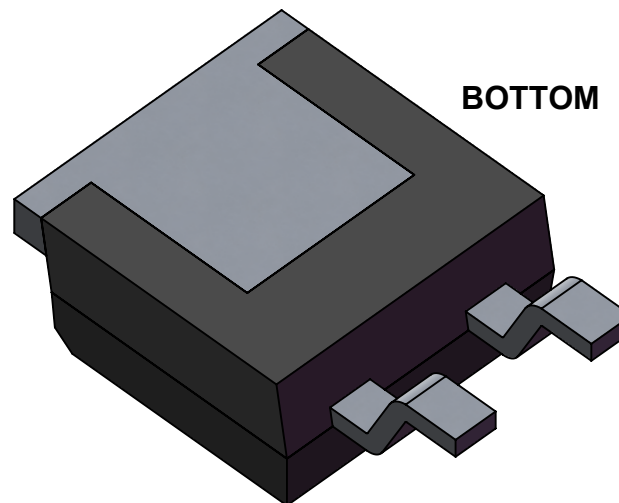

BOTTOM

MODELS

TopLine[®]			
TITLE		D2PAK-DC123 JUMPER	
SCALE	SIZE	DRAWING NO.	REV
5:1	A	158604	A
DO NOT SCALE DRAWING			SHEET 2 OF 6

PART NUMBERING SYSTEM

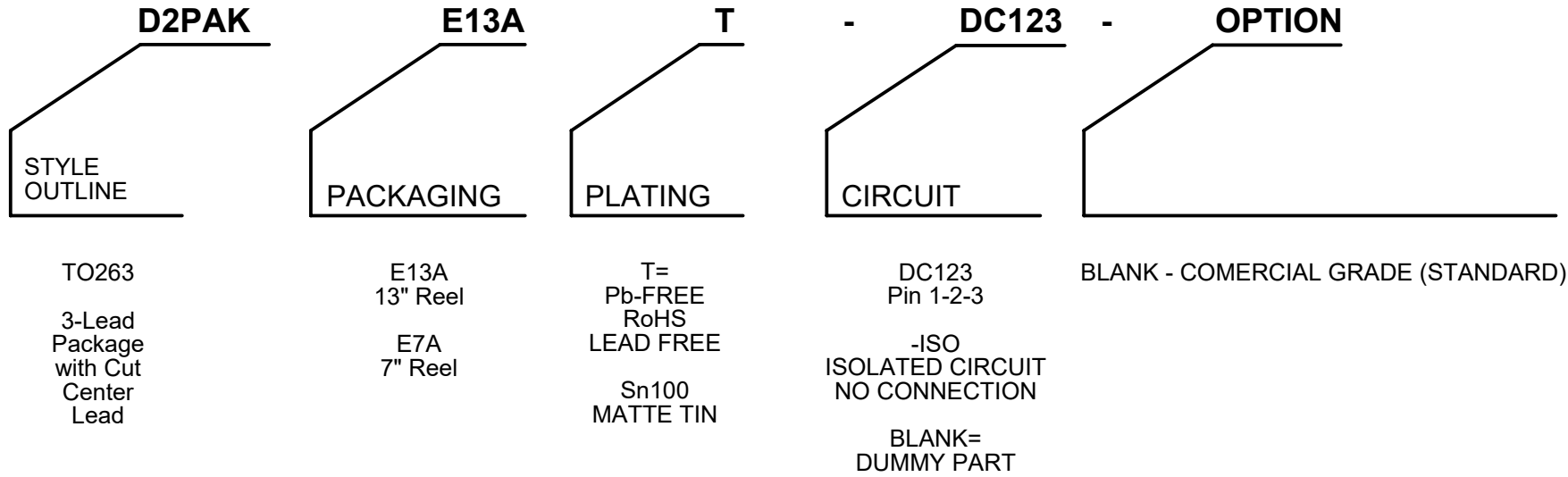

PART NUMBER	SHORTED PINS	NOTES	RoHS Pb-FREE	MSL LEVEL	HALOGEN FREE	GRADE	TOP MARK
D2PAK E13A-T-DC123	1 ~ 2 ~ 3	ALL	YES	3	NO	COMMERCIAL	DC123

TopLine®			
TITLE		D2PAK-DC123 JUMPER	
SCALE	SIZE	DRAWING NO.	REV
NONE	A	158604	A
DO NOT SCALE DRAWING			SHEET 3 OF 6

TAPE SPECIFICATION SURFACE MOUNT DEVICE

13 INCH PACKAGE REEL

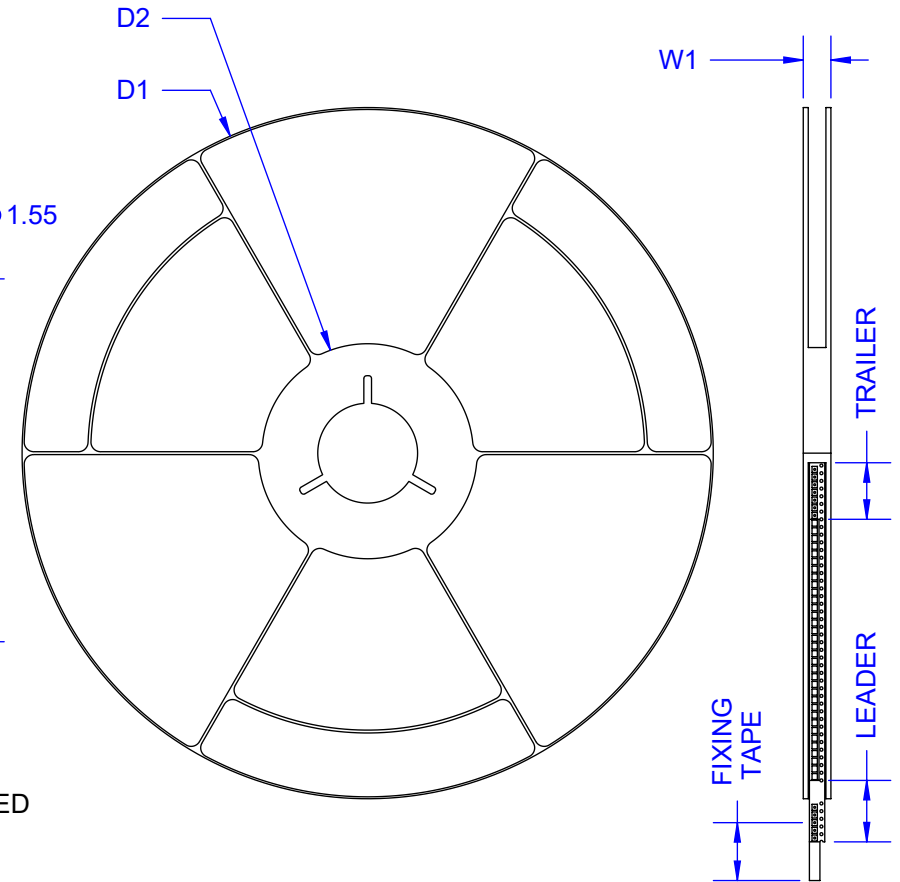
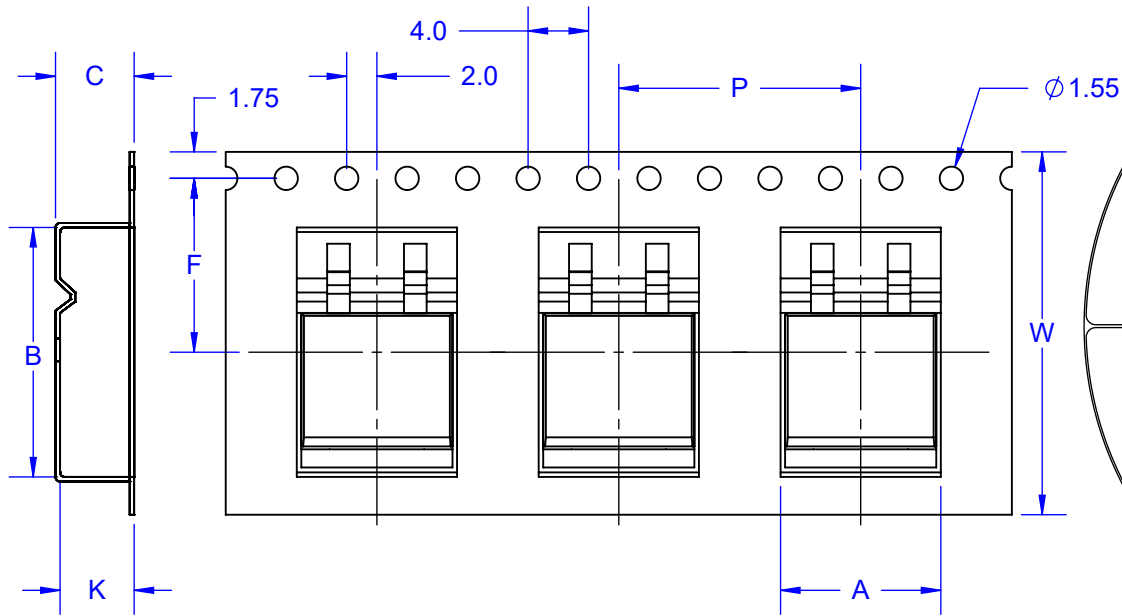

DIRECTION OF UNREELING →

PARTS ARE NOT POLORIZED

ALL DIMENSIONS IN mm.

TAPE AND REEL DIMENSIONS		E13A 13-INCH
	SYMBOL	D2PAK
TAPE WIDTH	W	24
PITCH OF COMPONENTS	P	16
POCKET WIDTH	A	10.6
POCKET LENGTH	B	16.5
POCKET DEPTH	K	4.9
CARRIER THICKNESS	C	5.2
REEL DIAMETER	D1	330
HUB DIAMETER	D2	60
PUNCH HOLE POSITION	F	11.5
MAX REEL WIDTH	W1	28
QUANTITY (PSC)	-	800

TopLine®			
TITLE		D2PAK-DC123 JUMPER	
SCALE	SIZE	DRAWING NO.	REV
2:1	A	166539	A
DO NOT SCALE DRAWING			SHEET 4 OF 6

PC BOARD LAND PATTERN

RECOMMENDED SOLDERING FOOTPRINT*

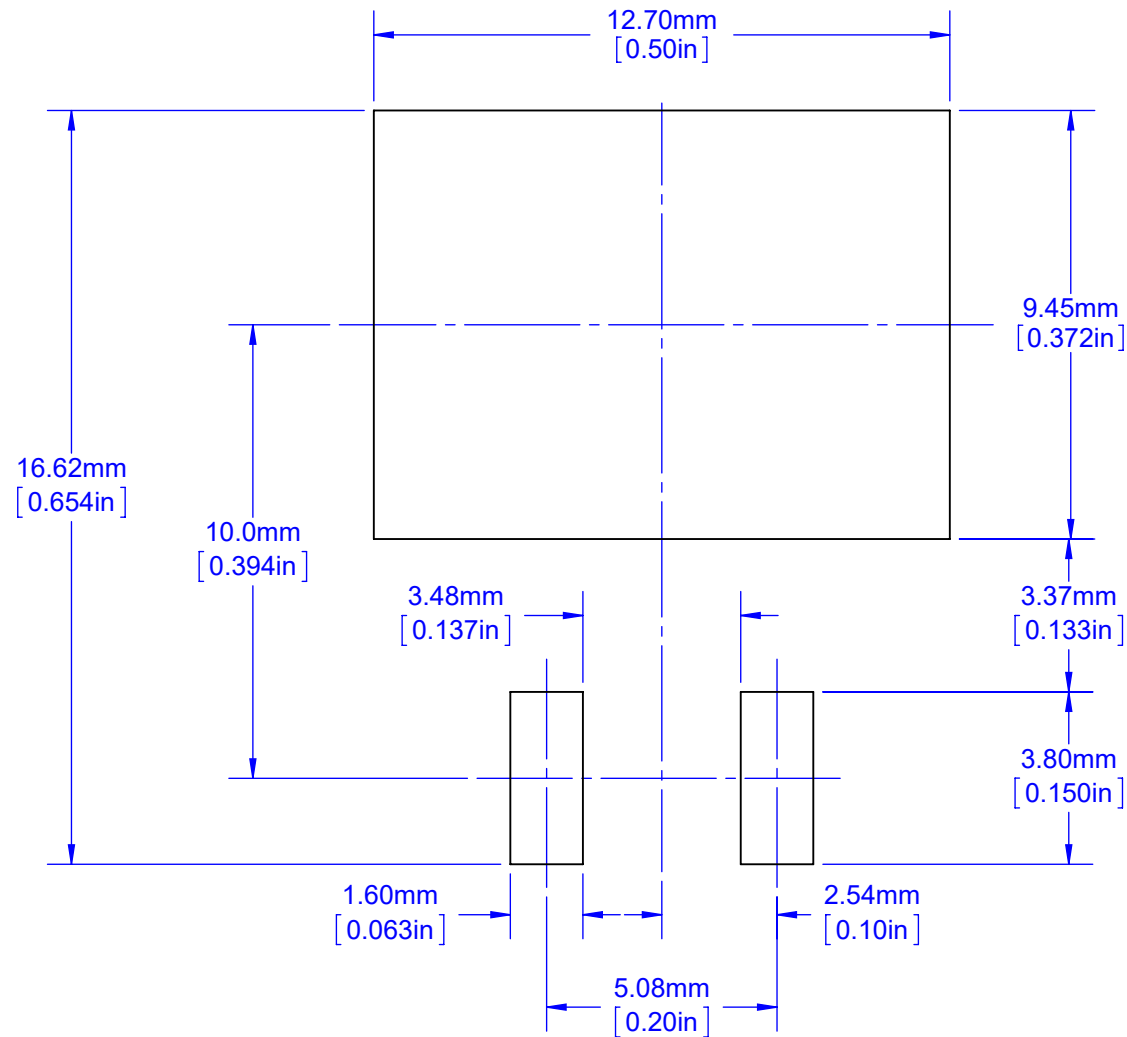

Notes: (Unless Otherwise Specified).

1) DIMENSIONS IN mm. [INCHES]

2) PCB BOARD DIMENSIONS ARE PRESENTED ONLY AS A GUIDELINE
DESIGNERS SHOULD USE THEIR OWN EXPERIENCE WHEN DESIGNING PCB.

TopLine[®]

TITLE		D2PAK-DC123 JUMPER	
SCALE	SIZE	DRAWING NO.	REV
6:1	A	166539	A
DO NOT SCALE DRAWING			SHEET 5 OF 6

LEAD FREE REFLOW PROFILE OF SMD PACKAGE

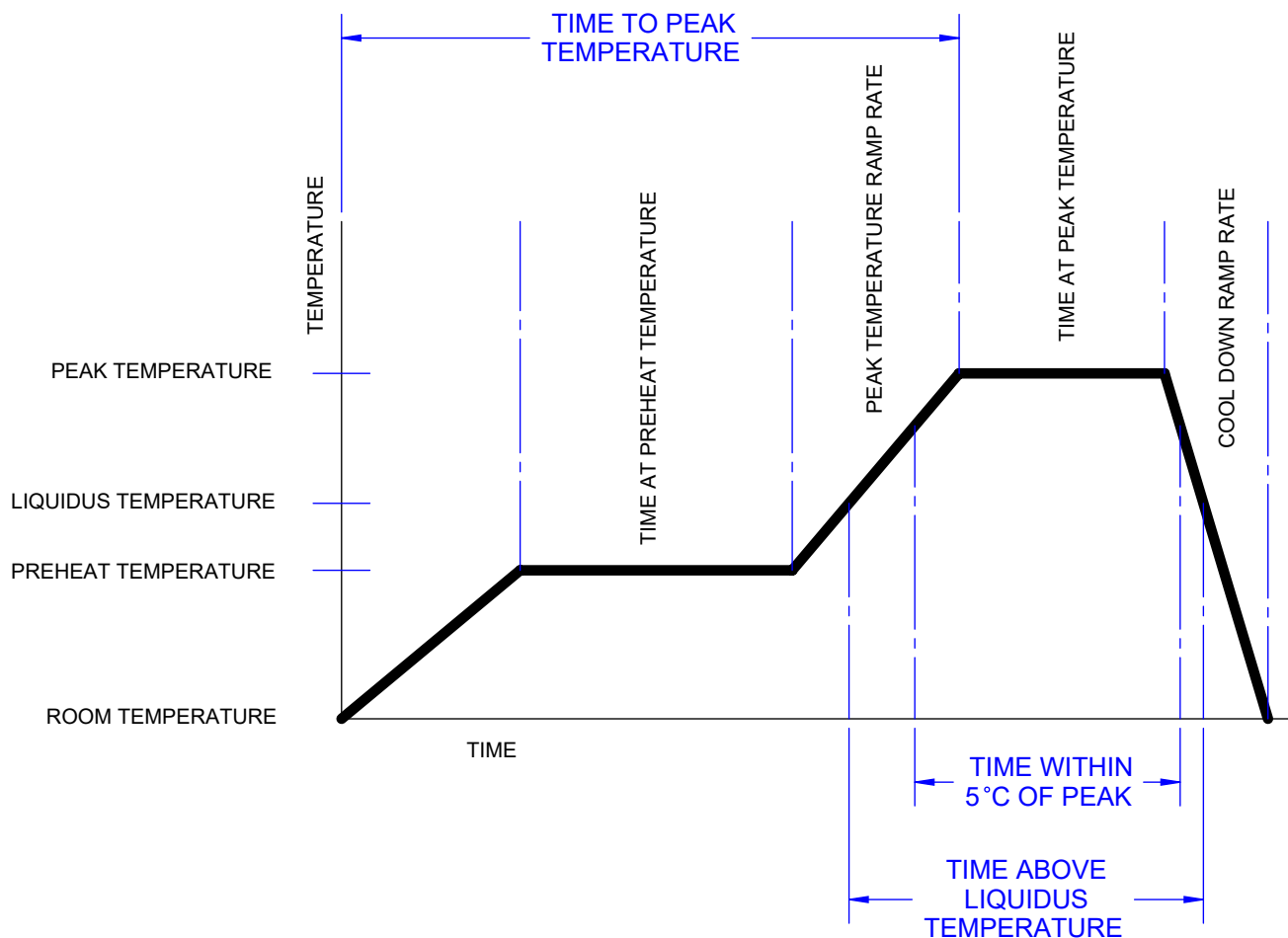

DESCRIPTION	REQUIREMENT
AVERAGE PREHEAT RAMP RATE	3°C /SECOND MAXIMUM
PREHEAT TEMPERATURE	150°C MINIMUM, 200°C MAXIMUM
PREHEAT TIME	60 TO 120 SECONDS
RAMP TO PEAK	3°C /SECOND MAXIMUM
TIME OVER LIQUIDUS (217°C)	60 TO 260 SECONDS
PEAK TEMPERATURE	260°C +0/-5°C
TIME WITHING 5°C OF PEAK	10 TO 30 SECONDS
RAMP - COOL DOWN	6°C /SECONDS MAXIMUM
TIME 25°C TO PEAK	6 MINUTES MAXIMUM

TopLine®

TITLE D2PAK-DC123
JUMPER

SCALE NONE	SIZE A	DRAWING NO. 158604	REV A
---------------	-----------	-----------------------	----------

DO NOT SCALE DRAWING

SHEET 6 OF 6