

<u>BALLS</u>	<u>PITCH</u>	<u>SIZE</u>	<u>MATRIX</u>	<u>ROWS</u>	<u>CENTER</u>	<u>MAT'L</u>
6	0.5mm	1.5 x 1.0mm	2 x 3	full	na	Wafer Level Si

BALL VIEW

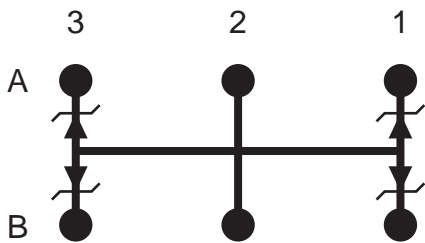

BOTTOM SIDE (TOP X-RAY VIEW)

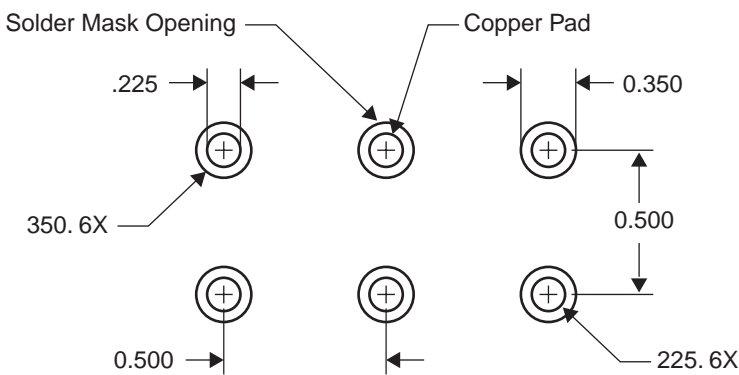
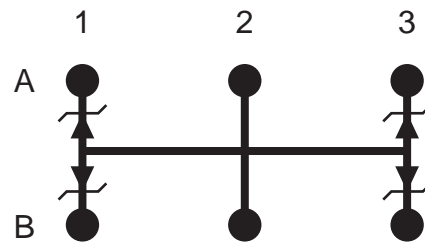

TEST VEHICLE BOARD

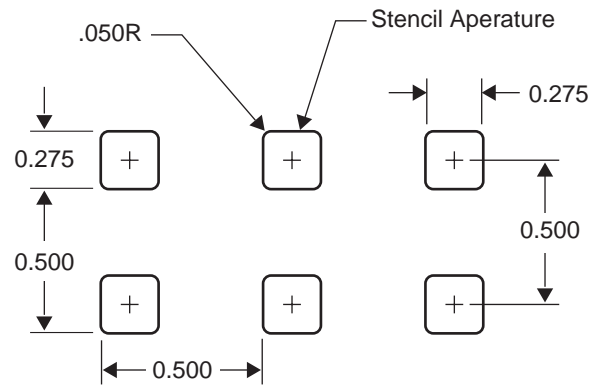

RECOMMENDED STENCIL

CSP6E7A.5C-DC023 Lead Free



<u>BALLS</u>	<u>PITCH</u>	<u>SIZE</u>	<u>MATRIX</u>	<u>ROWS</u>	<u>CENTER</u>	<u>MAT'L</u>	TEL 1-714-898-3830
6	0.5mm	1.5 x 1.0mm	2 x 3	full	na	Wafer Level Si	info@topline.tv

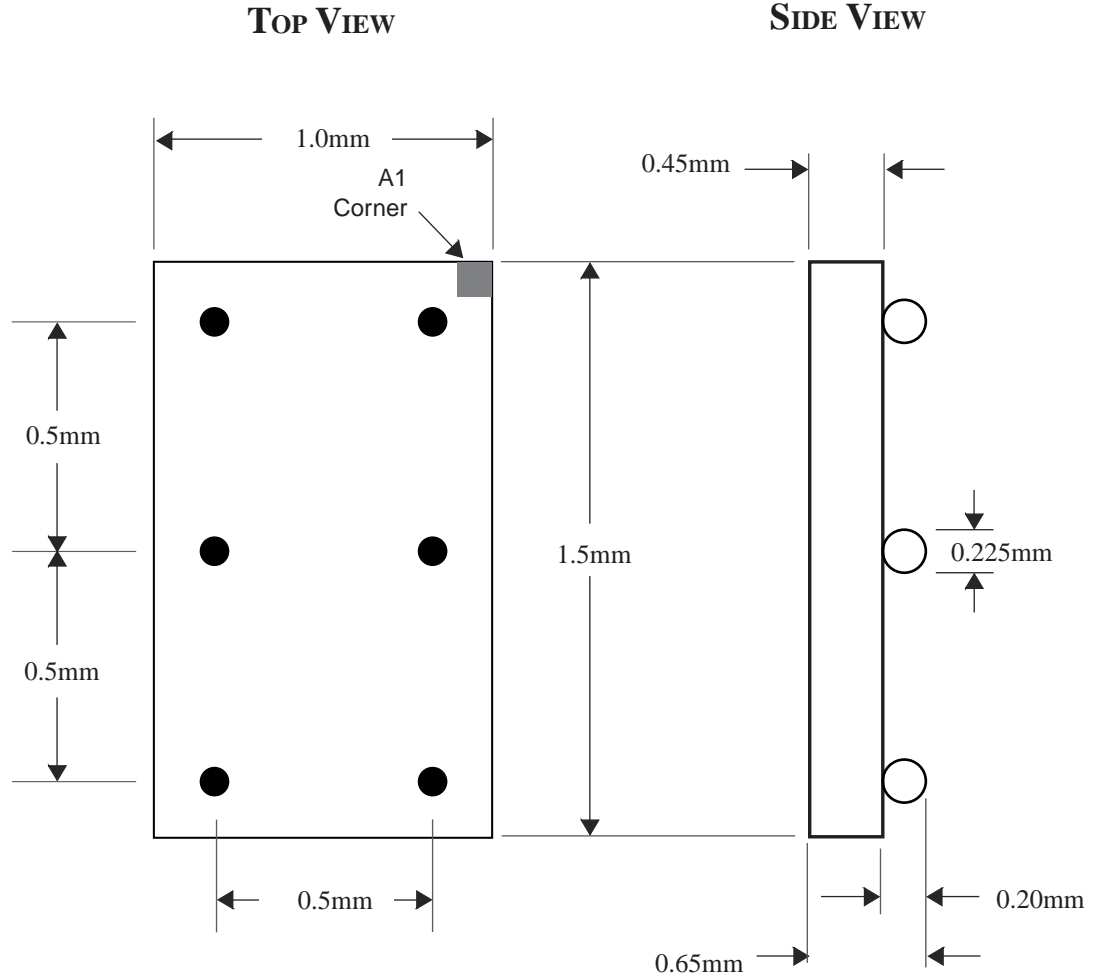

NOTES		REVISIONS	
Note 1	Top marked F45U	Rev	Date
Note 2	Ball A1 locator mark positioned in corner	Changes _____	
Note 3	Ball Material: Sn95.5/Ag3.8/Cu0.7		
Note 4	Substrate Material: Si		
Note 5	JEDEC MO-211 BB		
		PACKAGING TRAYS	
		Reel Package, Plastic Tape 2mm pitch	
		Reel Quantity: 3000 and 500	