

TOP VIEW

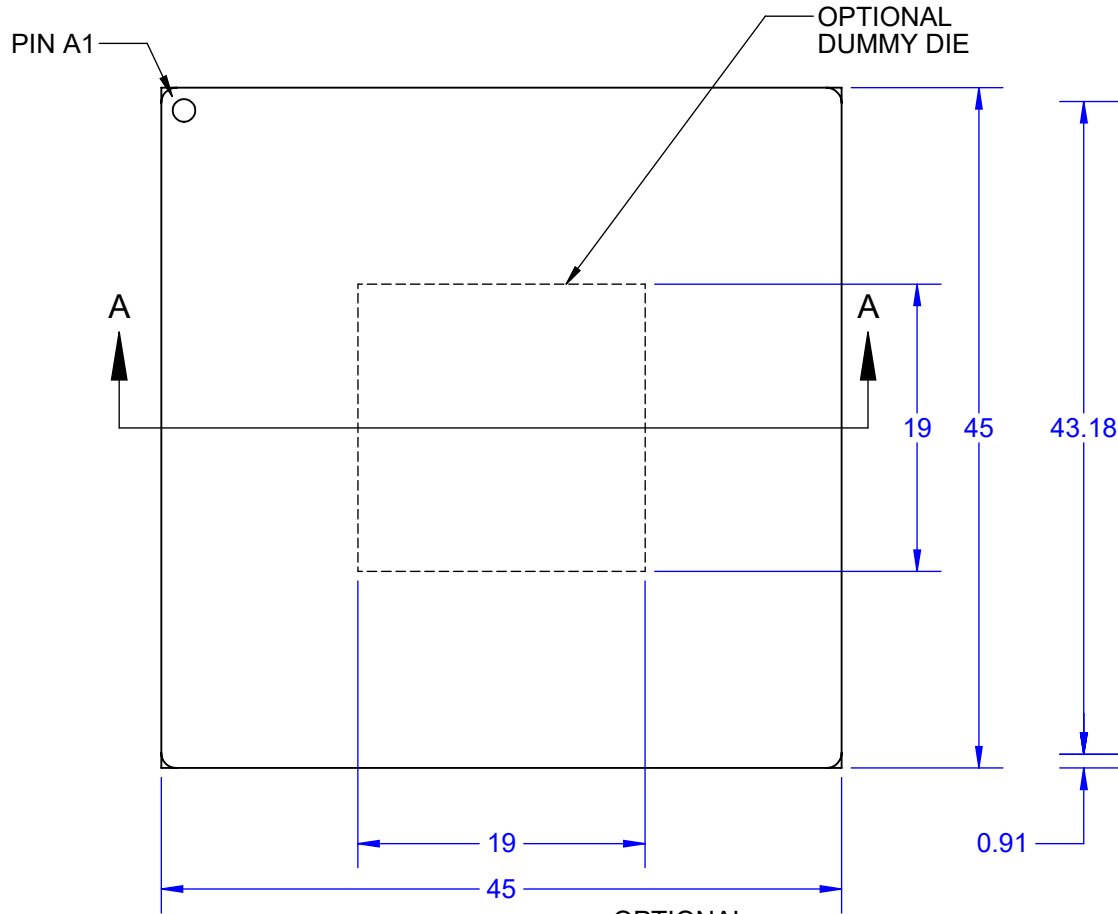

BALL VIEW

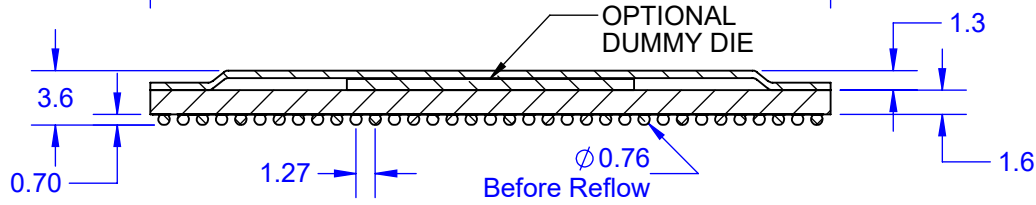
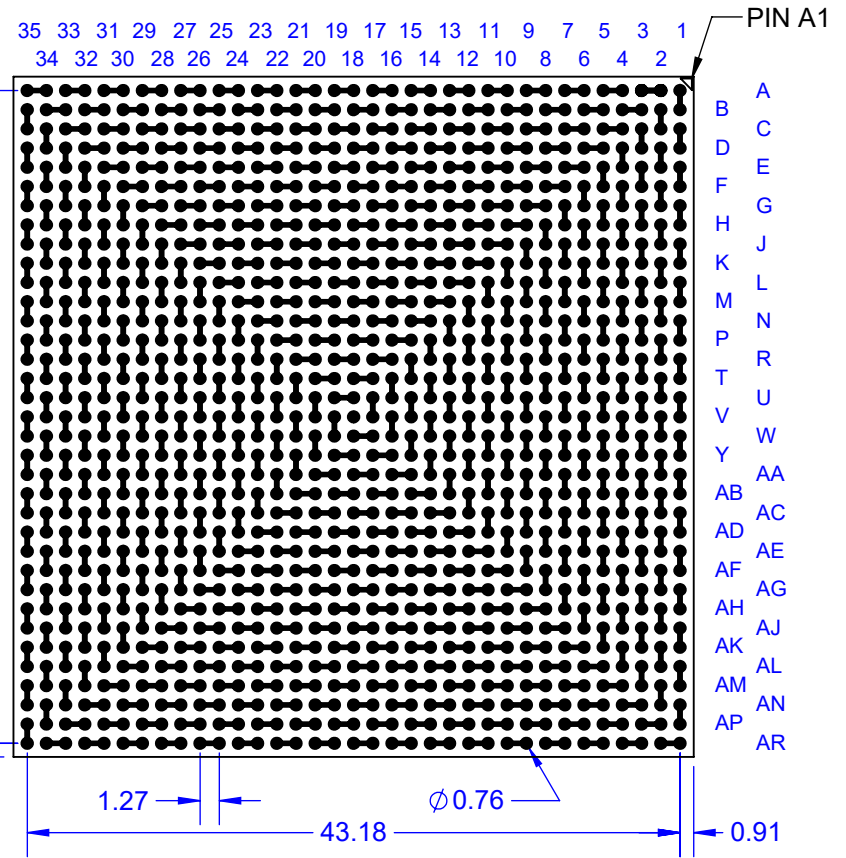

SECTION A-A

Notes: (Unless Otherwise Specified).

- 1) ALL DIMENSIONS ARE IN MM.
- 2) SOLDER BALL ALLOY: SEE PART NUMBER TABLE.
- 3) BALL DIAMETER (BEFORE REFLOW): 0.762mm (30 MIL).
- 4) SOLDER MASK DEFINED PAD OPENING: 0.610mm (24 MIL).
- 5) PAD Cu DIAMETER: 0.838mm (33 MIL).
- 6) SUBSTRATE MATERIAL: FR4 (ALTERNATE BT or Polyimide).
- 7) DUMMY DIE IS OPTIONAL.
- 8) DAISY CHAIN PATTERN (SEE PAGE 2).
- 9) MSL-3 RECOMMENDED BAKING 24 HOURS @ 125°C TO REMOVE MOISTURE PRIOR SOLDERING TO PC BOARD.

PART NUMBER TABLE

PART NUMBER	BALL ALLOY	Pb-FREE	RoHS	Si DIE
SBGA1225T1.27C-DC359D	Sn96.5/Ag3.0/Cu0.5	YES	YES	YES
SBGA1225T1.27-DC359D	Sn63/Pb37	NO	NO	YES

APPROVALS	DATE				
DRAWN T. Au	6/17/2021				
ENG M. Hart	6/17/2021	TITLE SBGA1225T1.27C-DC359D DAISY CHAIN DUMMY			
MFG		SCALE 2:1	SIZE A	DRAWING NO. 523592	REV A
QA		DO NOT SCALE DRAWING			SHEET 1 OF 8
CUST					
REVISED					

BALL VIEW

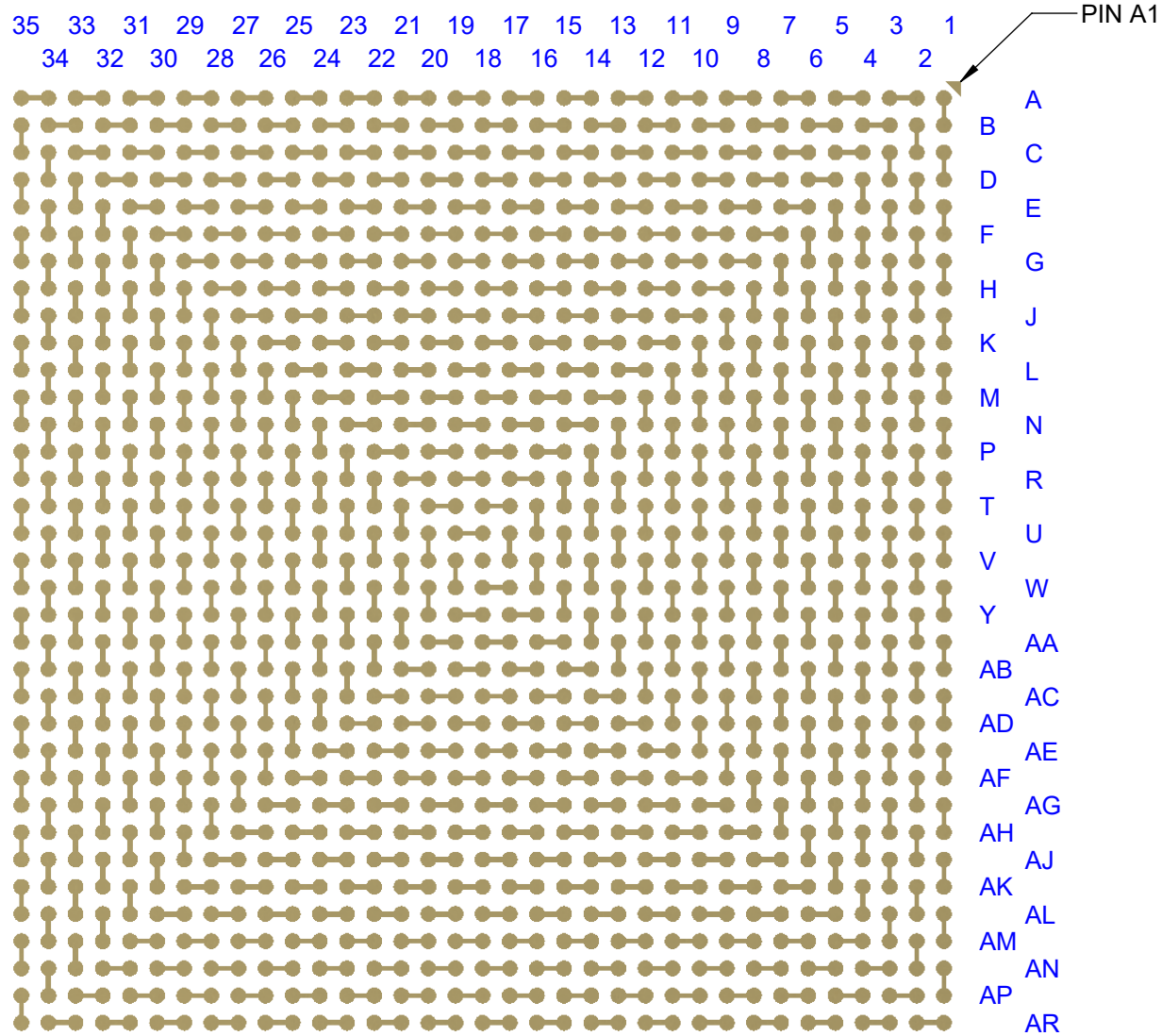

TopLine®			
TITLE SBGA1225T1.27C-DC359D DAISY CHAIN DUMMY			
SCALE 3:1	SIZE A	DRAWING NO. 523592	REV A
DO NOT SCALE DRAWING		SHEET 2 OF 8	

BOTTOM SIDE (TOP X-RAY VIEW)

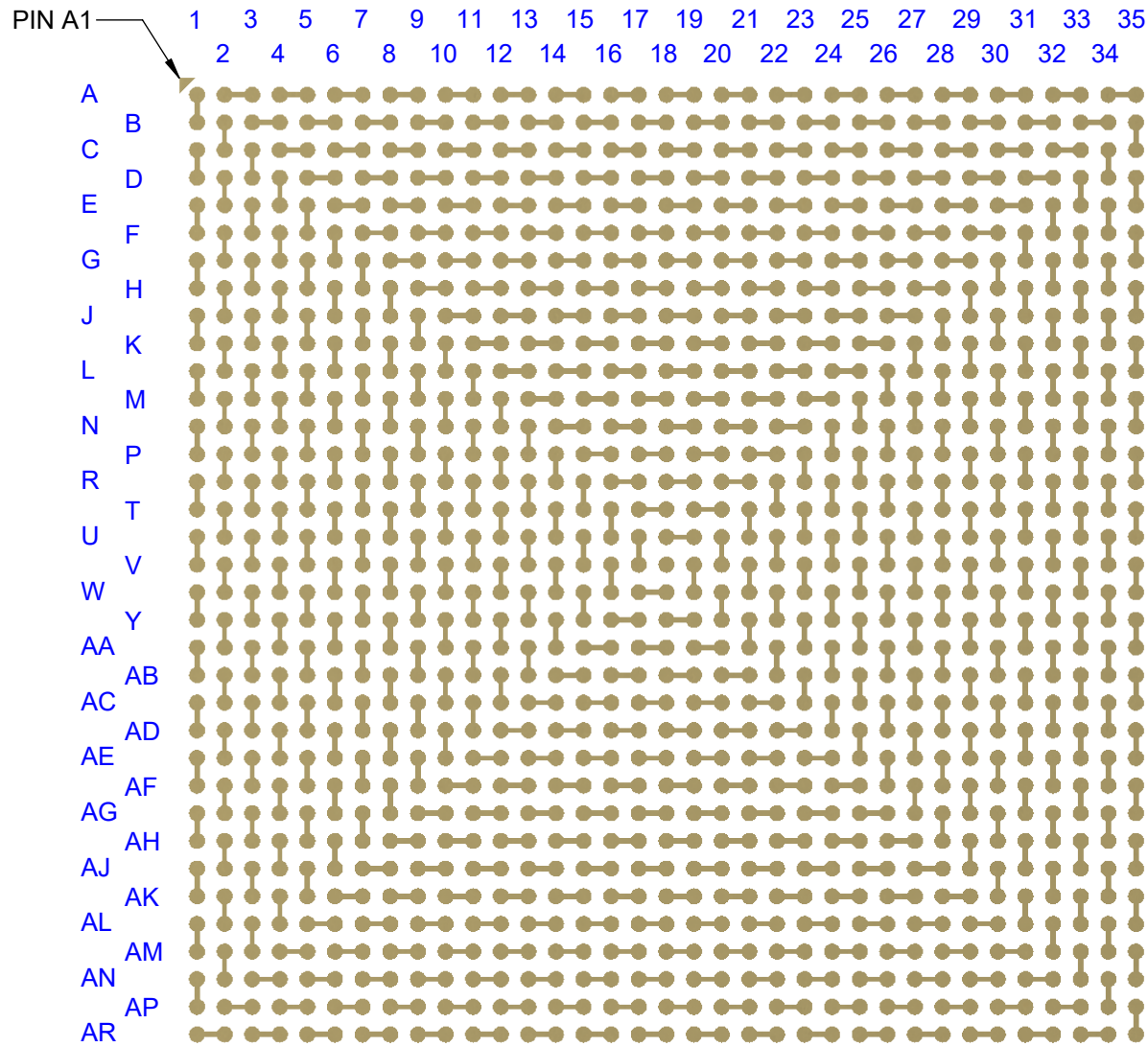

TopLine®			
TITLE SBGA1225T1.27C-DC359D DAISY CHAIN DUMMY			
SCALE 3:1	SIZE A	DRAWING NO. 523592	REV A
DO NOT SCALE DRAWING			SHEET 3 OF 8

TEST VEHICLE BOARD

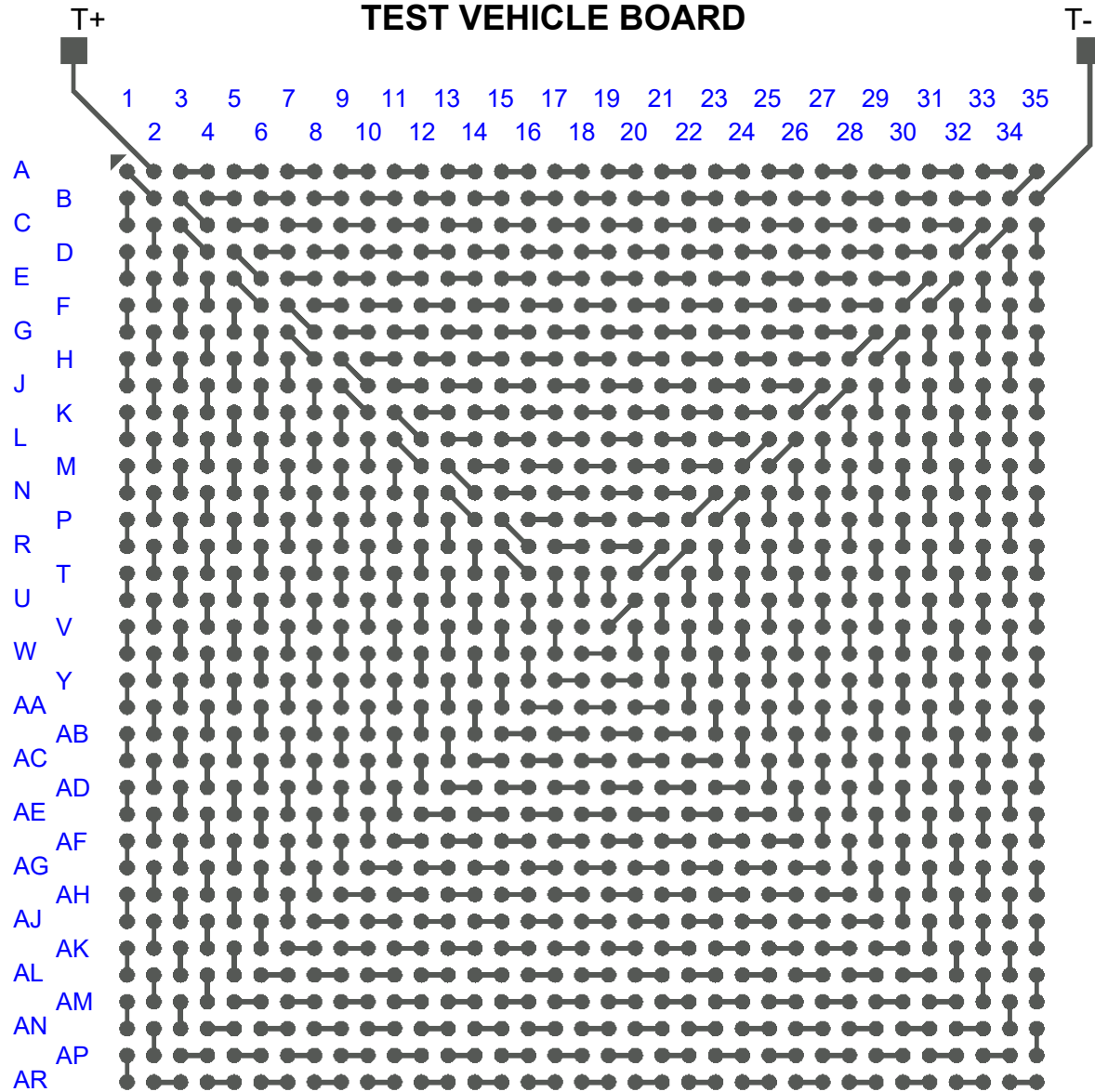

Notes:

- 1) PCB BOARD DIMENSIONS ARE PRESENTD ONLY AS A GUIDELINE. DESIGNERS SHOULD USE THEIR OWN EXPERIENCE WHEN DESIGNING PCB.
- 2) PCB Cu BALL PAD DIAMETER 0.838mm [33 MIL].
- 3) PCB DAISY CHAIN TRACING LINE WIDTH 0.254mm [10 MIL].
- 4) SMD (SOLDER MASK DEFINED) PAD OPENING 0.61mm [24 MIL].



TITLE			
SBGA1225T1.27C-DC359D DAISY CHAIN DUMMY			
SCALE	SIZE	DRAWING NO.	REV
3:1	A	523592	A
DO NOT SCALE DRAWING			SHEET 4 OF 8

AFTER MOUNTING

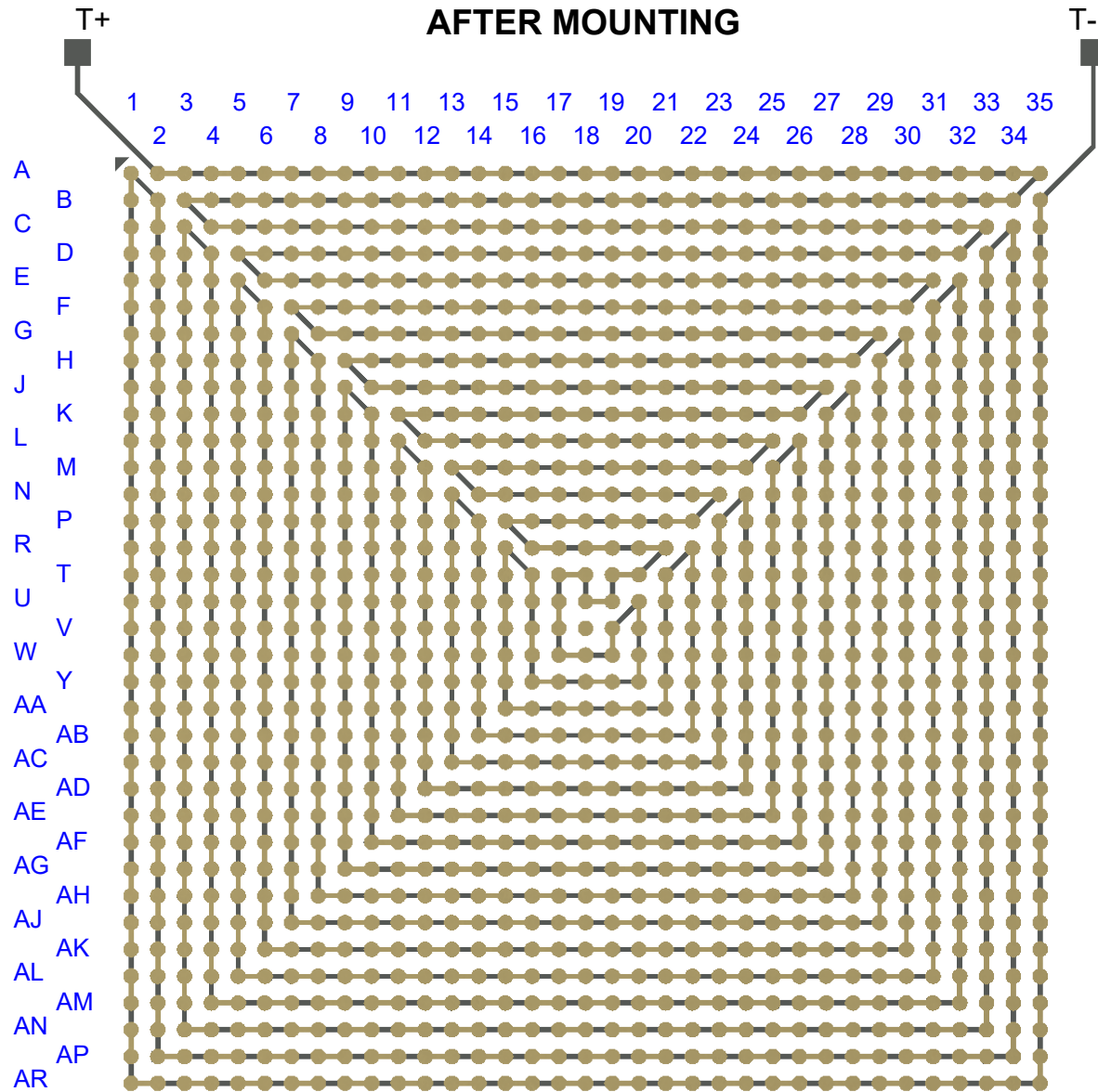

TopLine[®]

TITLE SBGA1225T1.27C-DC359D
DAISY CHAIN DUMMY

SCALE 3:1	SIZE A	DRAWING NO. 523592	REV A
--------------	-----------	-----------------------	----------

DO NOT SCALE DRAWING

SHEET 5 OF 8

BALL VIEW

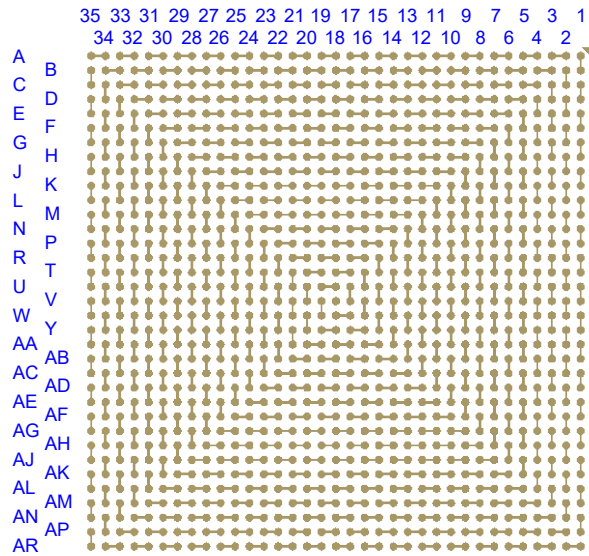

BOTTOM SIDE (TOP X-RAY VIEW)

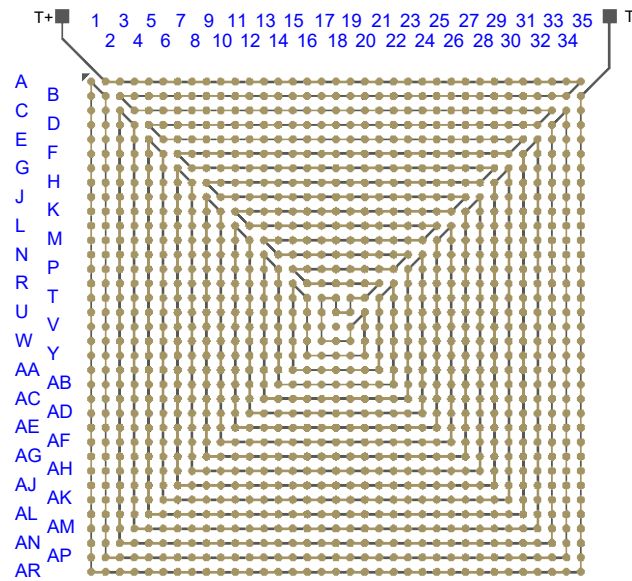
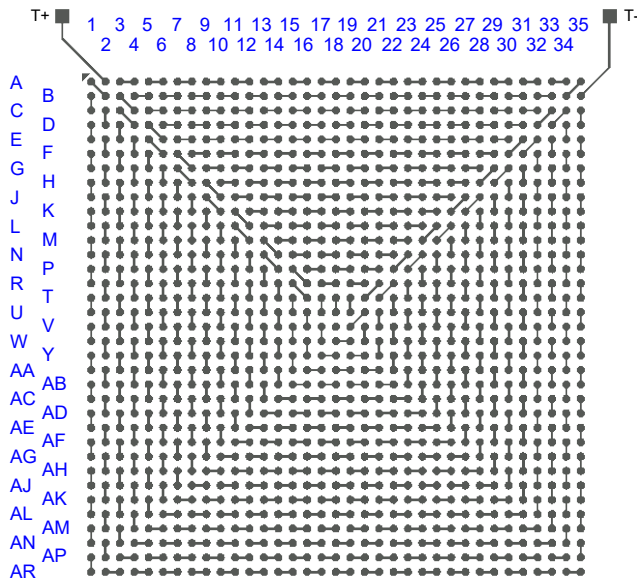
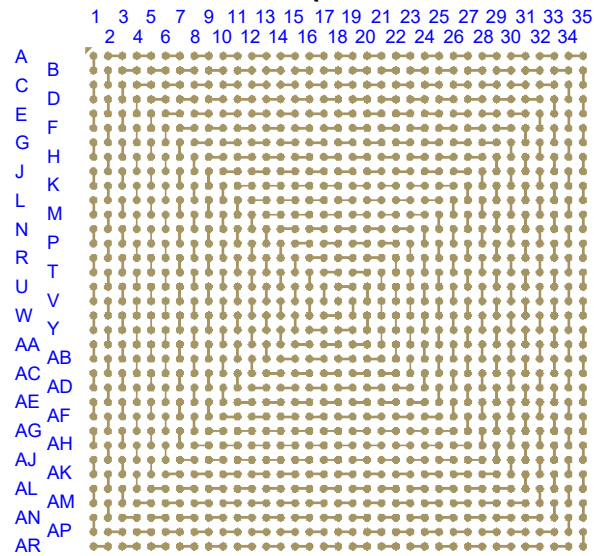

TEST VEHICLE BOARD

AFTER MOUNTING

Notes:

- 1) PCB BOARD DIMENSIONS ARE PRESENTD ONLY AS A GUIDELINE. DESIGNERS SHOULD USE THEIR OWN EXPERIENCE WHEN DESIGNING PCB.
- 2) PCB Cu BALL PAD DIAMETER 0.838mm [33 MIL].
- 3) PCB DAISY CHAIN TRACING LINE WIDTH 0.254mm [10 MIL].
- 4) SMD (SOLDER MASK DEFINED) PAD OPENING 0.61mm [24 MIL].

TopLine®			
TITLE		SBGA1225T1.27C-DC359D DAISY CHAIN DUMMY	
SCALE	SIZE	DRAWING NO.	REV
3:2	A	523592	A
DO NOT SCALE DRAWING			SHEET 6 OF 8

MODEL

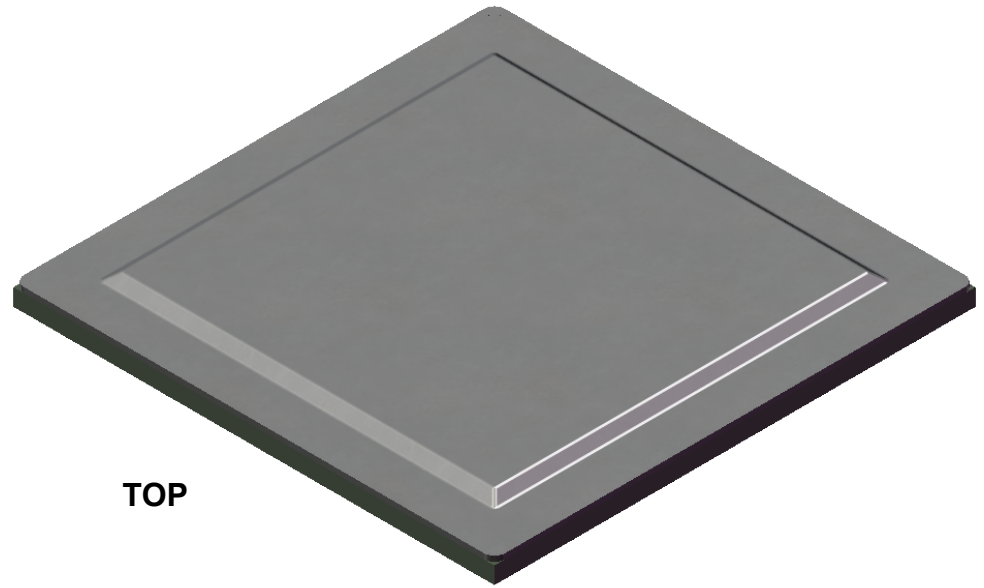

TOP

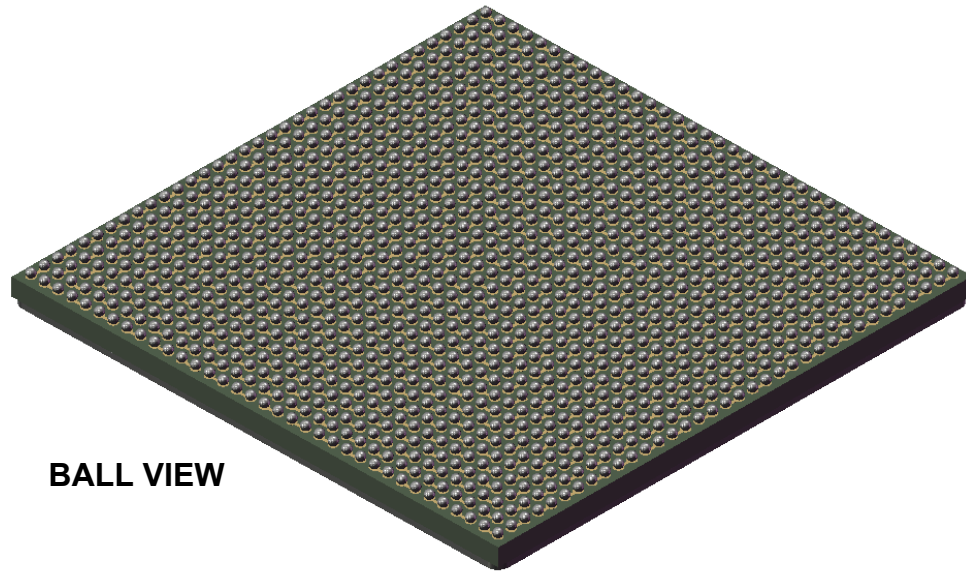

BALL VIEW

TopLine®

TITLE SBGA1225T1.27C-DC359D
DAISY CHAIN DUMMY

SCALE 2:1	SIZE A	DRAWING NO. 523592	REV A
--------------	-----------	-----------------------	----------

DO NOT SCALE DRAWING

SHEET 7 OF 8

HEAT SPREADER

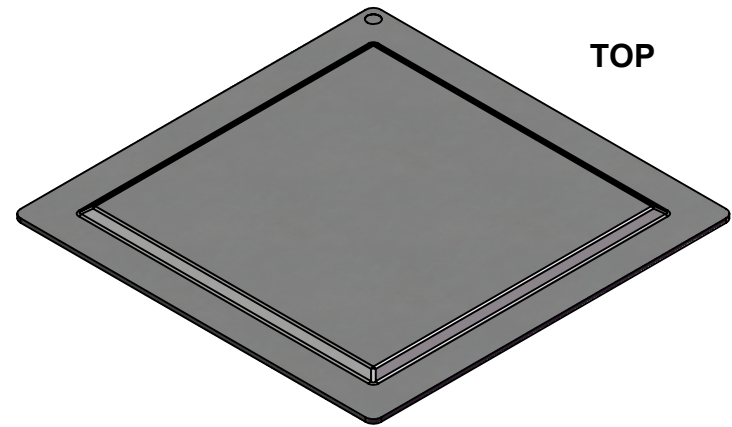
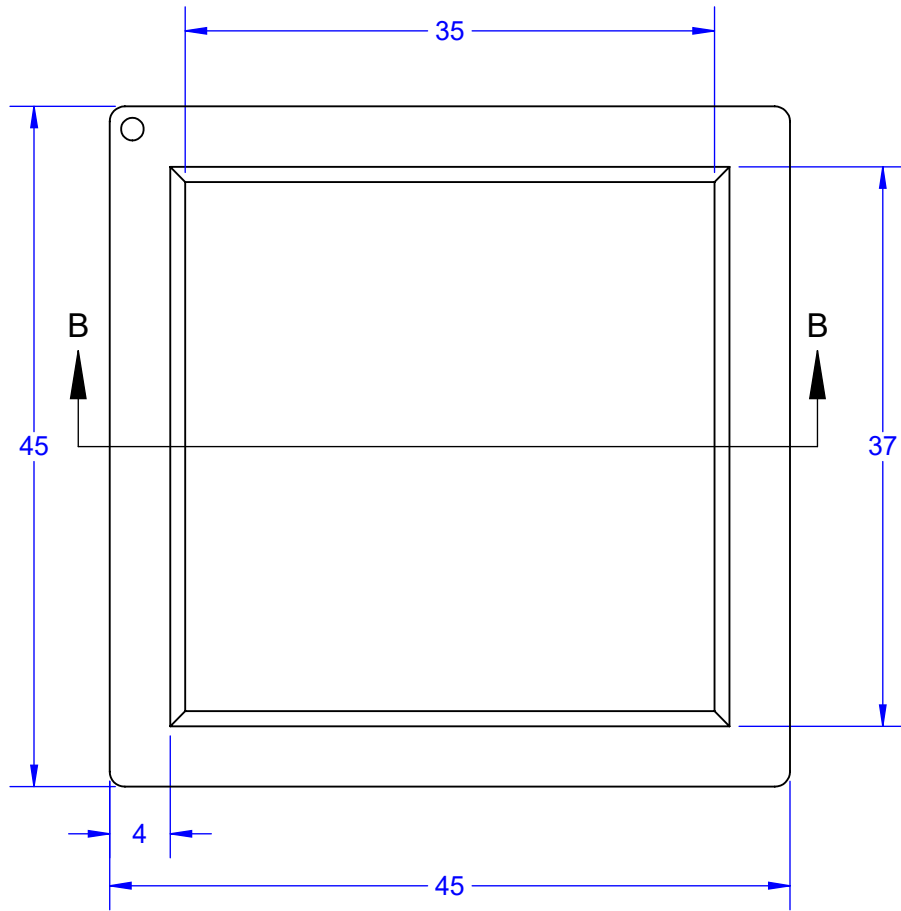

TOP

MODEL

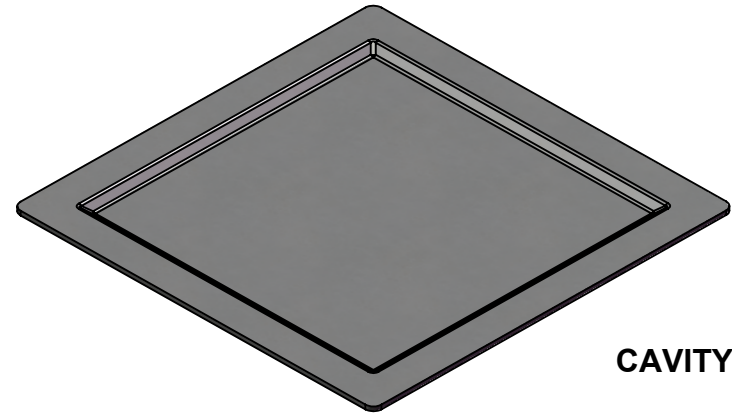

CAVITY

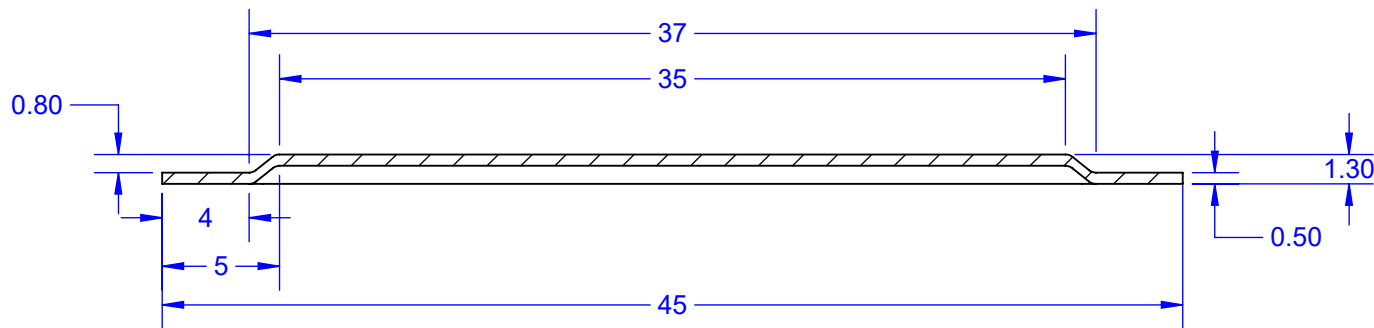

SECTION B-B
SCALE 3:1

TopLine®			
TITLE		H-CAP45mm 45mm Heat Spreader	
SCALE	SIZE	DRAWING NO.	REV
2:1	A	245710	A
DO NOT SCALE DRAWING			SHEET 8 OF 8