

SECTION A-A

PART NUMBER TABLE

PART NUMBER	BALL ALLOY	BALL ALLOY	RoHS	Si DIE
SBGA324T1.0C-DC224D	Sn96.5/Ag3.0/Cu0.5	SAC305	YES	YES
SBGA324T1.0-DC224D	Sn63/Pb37	Sn63	NO	YES

Notes: (Unless Otherwise Specified).

- 1) ALL DIMENSIONS ARE IN MM.
- 2) SOLDER BALL ALLOY: SEE PART NUMBER TABLE.
- 3) BALL DIAMETER (BEFORE REFLOW):  $\phi 0.61$ mm [24 MIL].
- 4) SOLDER MASK DEFINED PAD OPENING: 0.508mm [20 MIL].
- 5) PAD Cu DIAMETER: 0.636mm [25 MIL].
- 6) SUBSTRATE: BT - CTE 10ppm/°C Young's Modulus 27GPa.
- 7) DUMMY DIE 12.168 x 11.912mm (675 $\mu$ m Thick).
- 8) DAISY CHAIN PATTERN (SEE PAGE 2).
- 9) MSL-3 RECOMMENDED BAKING 24 HOURS @ 125°C TO REMOVE MOISTURE PRIOR TO SOLDERING TO PC BOARD.

APPROVALS		DATE				
DRAWN	T. Au	11/22/2021				
ENG	M. Hart	11/22/2021	TITLE			
MFG			SBGA324T1.0C-DC224D DAISY CHAIN DUMMY			
QA			SCALE	SIZE	DRAWING NO.	REV
CUST			3.5:1	A	512245	A
REVISED			DO NOT SCALE DRAWING			SHEET 1 OF 5

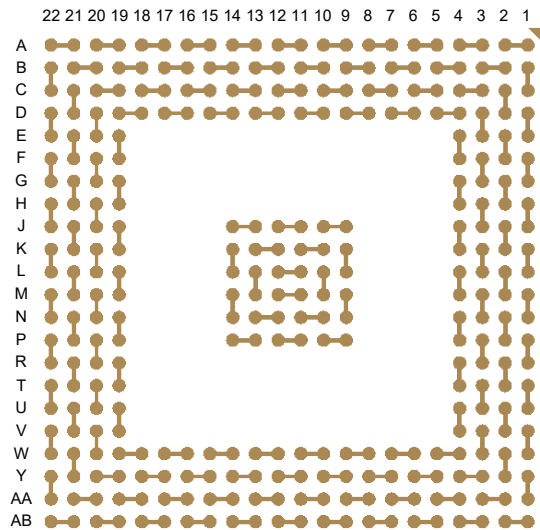

BALL VIEW

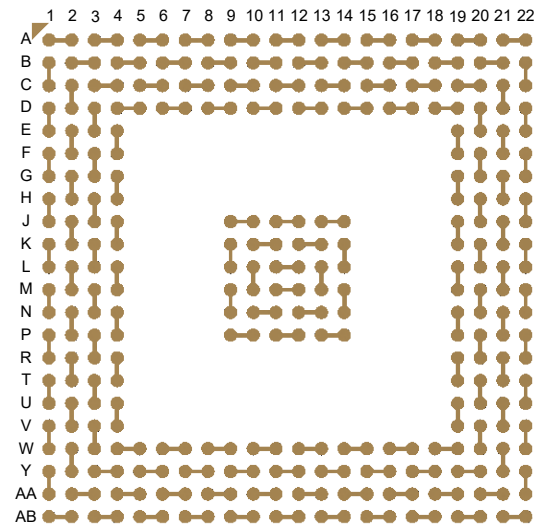

BOTTOM SIDE  
(TOP X-RAY VIEW)

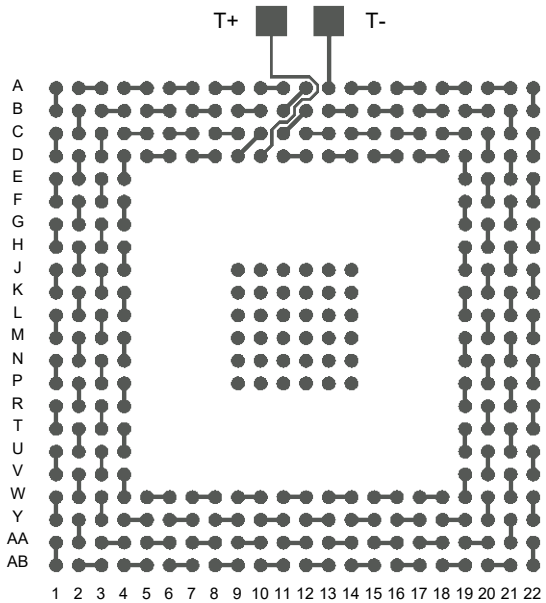

TEST VEHICLE  
BOARD

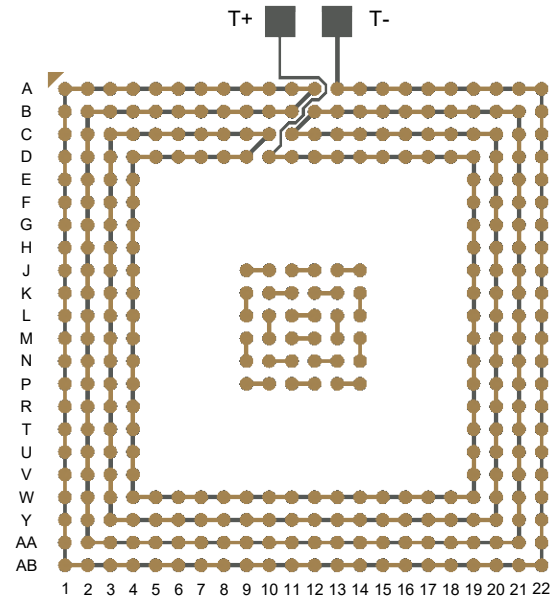

AFTER MOUNTING

Notes:

- 1) PCB BOARD DIMENSIONS ARE PRESENTED ONLY AS A GUIDELINE. DESIGNERS SHOULD USE THEIR OWN EXPERIENCE WHEN DESIGNING PCB.
- 2) PCB Cu BALL PAD DIAMETER 0.636mm (25 MIL).
- 3) PCB DAISY CHAIN TRACING LINE WIDTH 0.203mm (8 MIL).
- 4) SMD (SOLDER MASK DEFINED) PAD OPENING 0.508mm (20 MIL).

<b>TopLine®</b>			
TITLE		SBGA324T1.0C-DC224D DAISY CHAIN DUMMY	
SCALE	SIZE	DRAWING NO.	REV
3:1	A	512245	A
DO NOT SCALE DRAWING			SHEET 2 OF 5

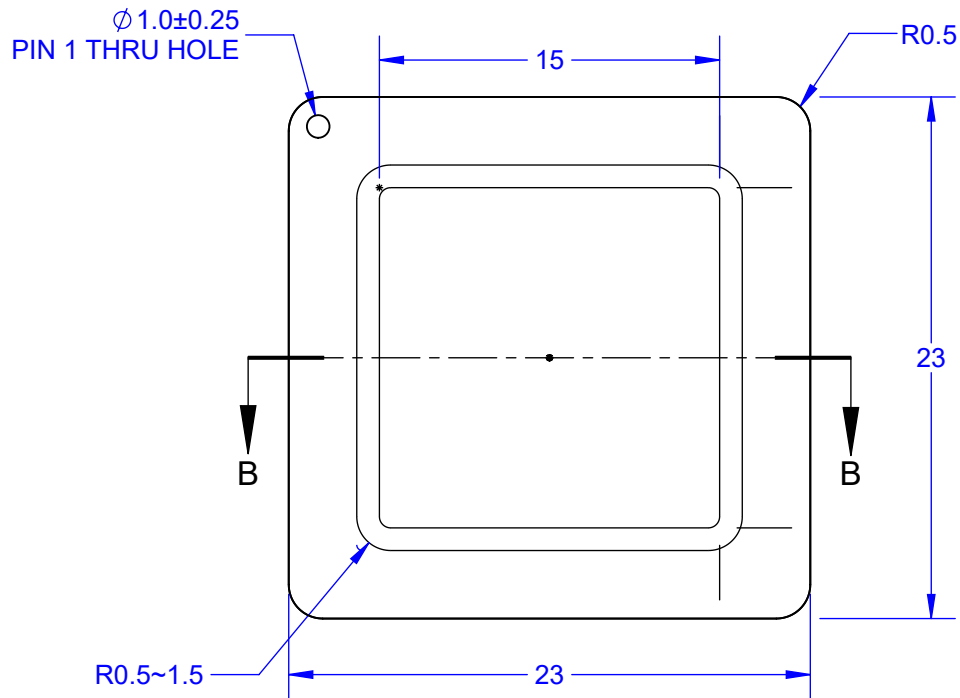

TOP



CAVITY

MODEL

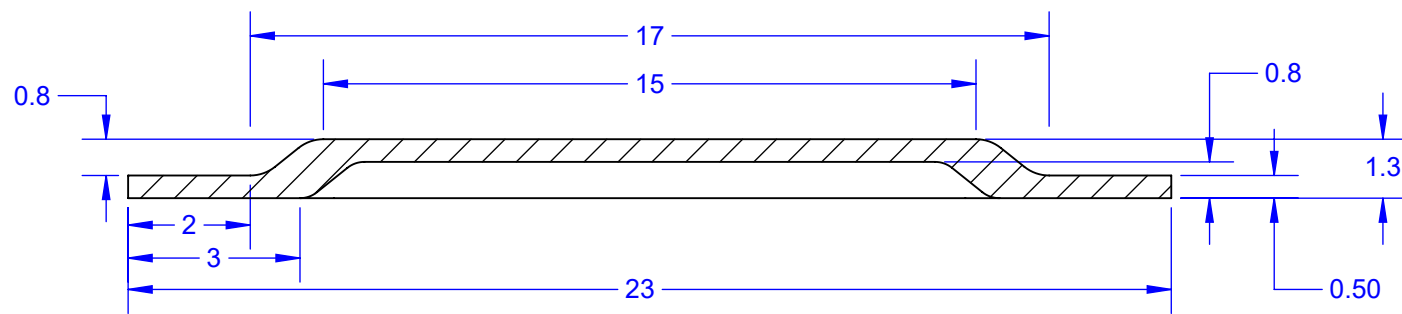

SECTION B-B  
SCALE 6 : 1

NOTE:

- 1) DIMENSION mm.
- 2) MATERIAL: OXYGEN FREE, 1/2H C1020 or C1100.

<b>TopLine®</b>			
TITLE		SBGA324T1.0C-DC224D DAISY CHAIN DUMMY	
SCALE	SIZE	DRAWING NO.	REV
3:1	A	512245	A
DO NOT SCALE DRAWING			SHEET 3 OF 5

**MODEL**

**TOP**

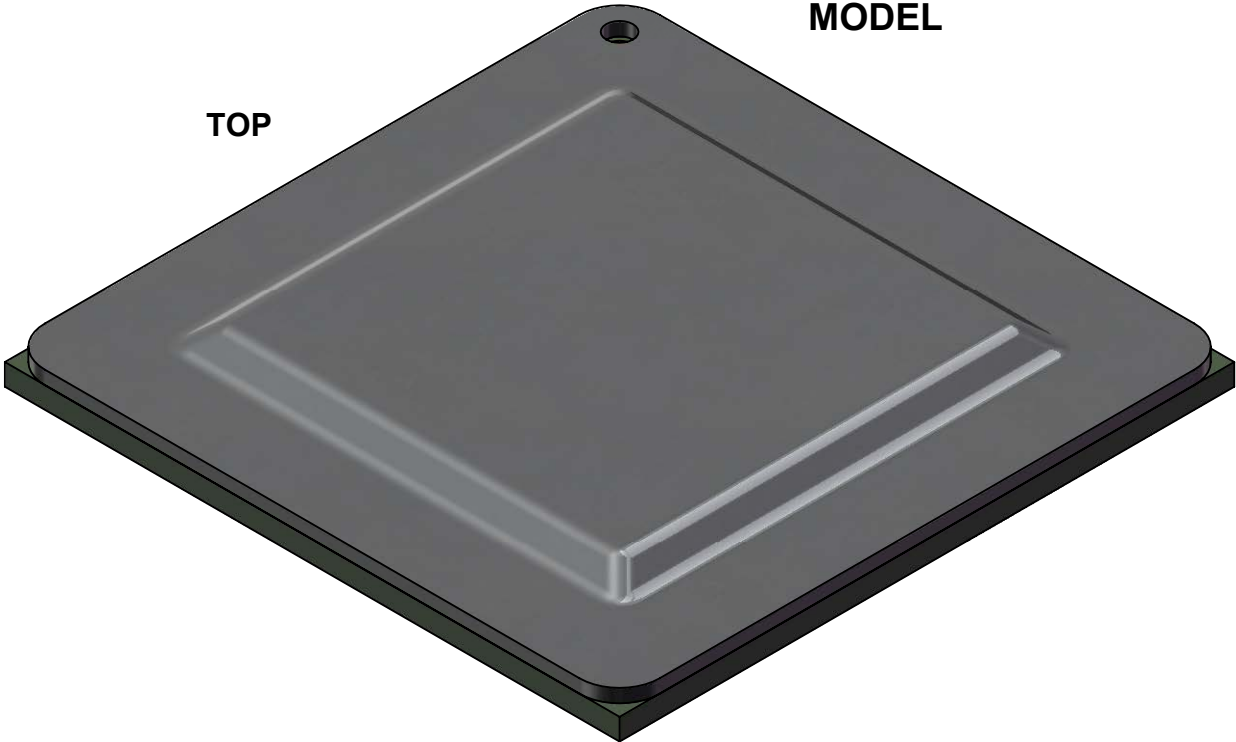

**BALL VIEW**

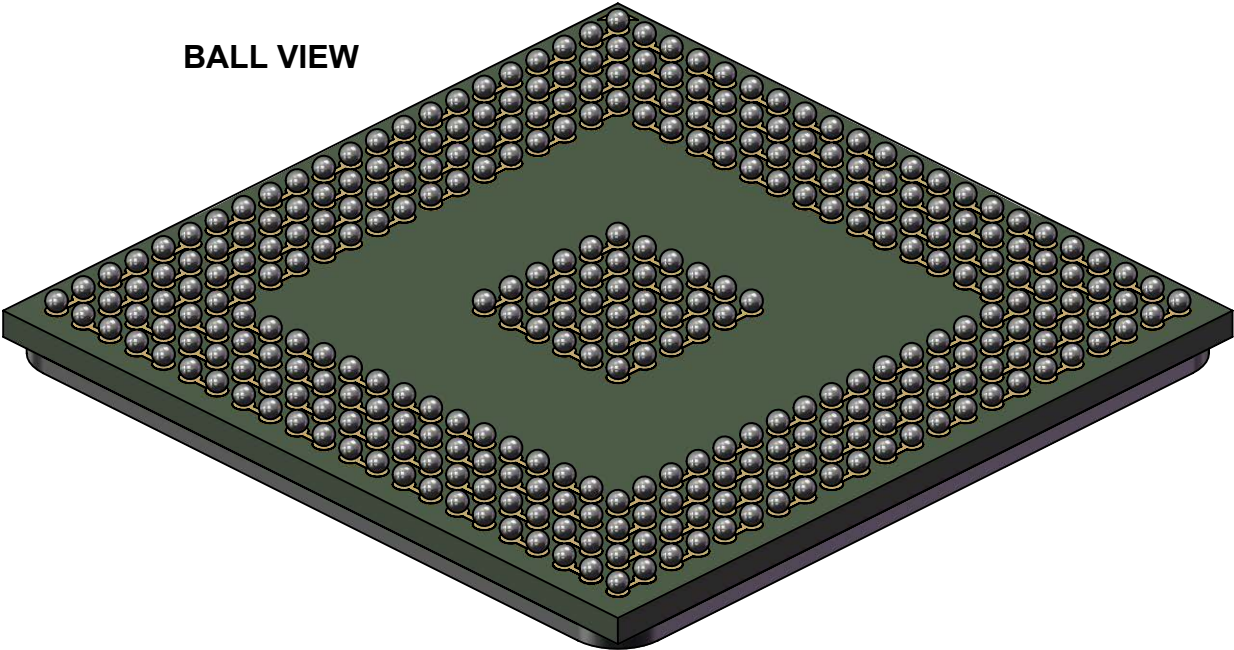

**TopLine®**

TITLE SBGA324T1.0C-DC224D  
DAISY CHAIN DUMMY

SCALE 5:1	SIZE A	DRAWING NO. 512245	REV A
--------------	-----------	-----------------------	----------

DO NOT SCALE DRAWING

SHEET 4 OF 5

**BOTTOM SOLDER MASK  
(RIGHT READING)**

22 21 20 19 18 17 16 15 14 13 12 11 10 9 8 7 6 5 4 3 2 1

A  
B  
C  
D  
E  
F  
G  
H  
J  
K  
L  
M  
N  
P  
R  
T  
U  
V  
W  
Y  
AA  
AB

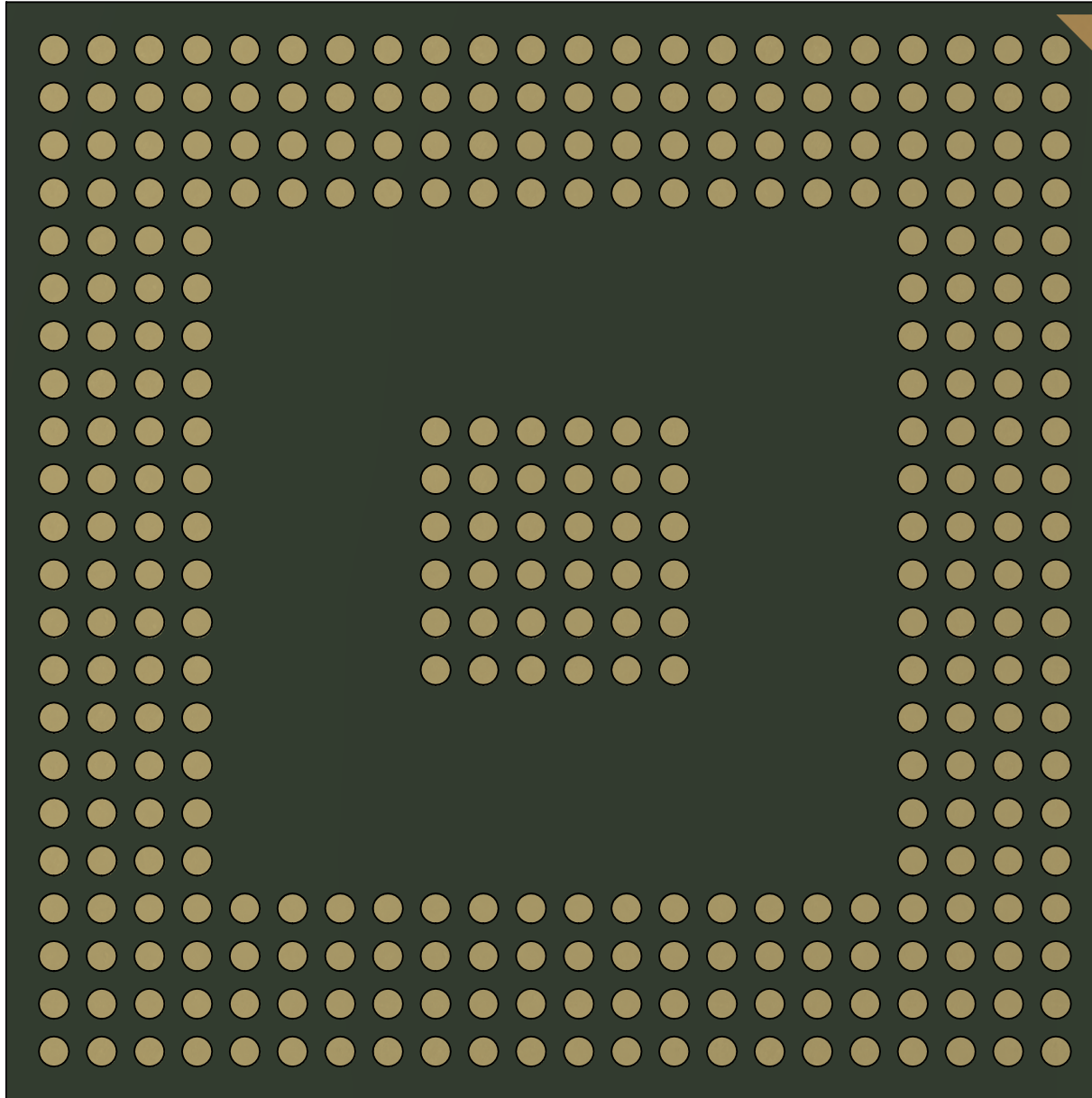

<b>TopLine®</b>			
TITLE		SBGA324T1.0C-DC224D DAISY CHAIN DUMMY	
SCALE	SIZE	DRAWING NO.	REV
7:1	A	512245	A
DO NOT SCALE DRAWING			SHEET 5 OF 5