

TOP VIEW

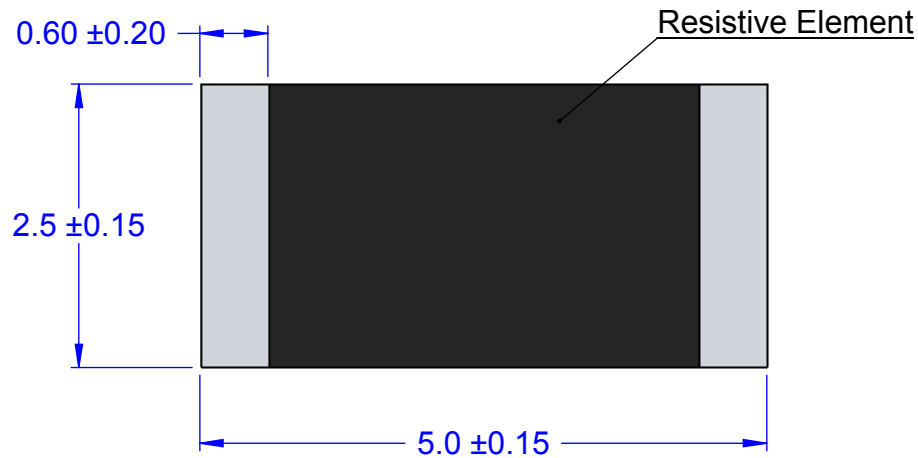

RECOMMENDED PCB PATTERN

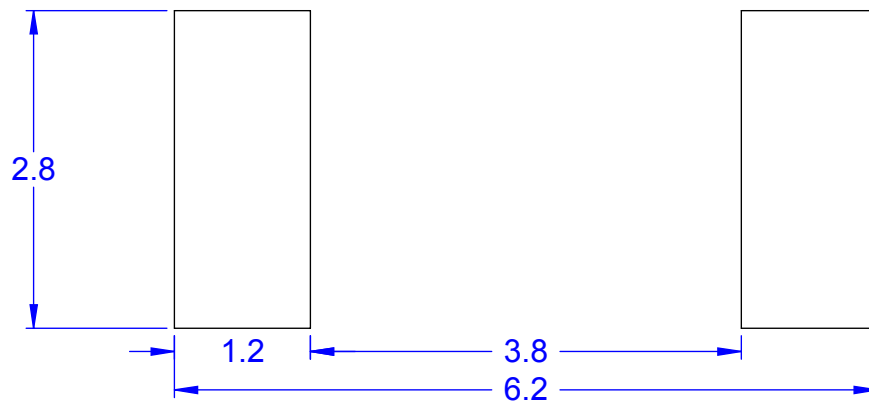

PCB DIMENSIONS ARE PRESENTED ONLY AS A GUIDELINE. DESIGNERS SHOULD USE THEIR OWN KNOWLEDGE BASE WHEN DESIGNING THE PCB.

STRUCTURE

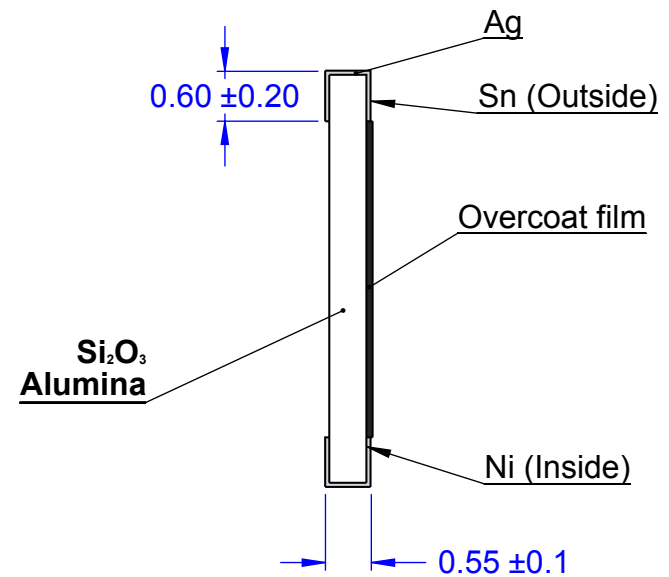

NOTES: Current Rating 2A @ 200WVDC

1. DIMENSIONS IN mm.
2. TERMINATION: Tin (Sn).
3. Pb-FREE AND HALOGEN FREE.

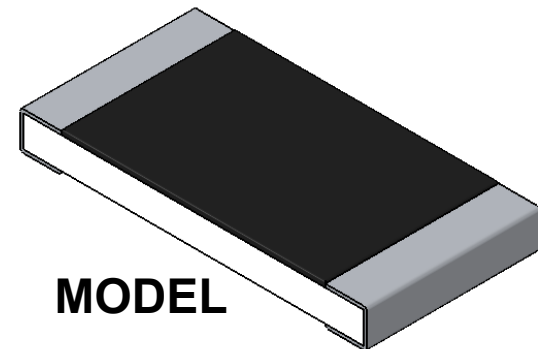

MODEL

APPROVALS	DATE	TopLine®			
DRAWN T. Au	08/03/12				
ENG M. Hart	08/03/12	TITLE SR2010 SMT RESISTOR			
MFG		SCALE	SIZE A	DRAWING NO. 122012	REV A
QA					
CUST		DO NOT SCALE DRAWING			SHEET 1 OF 2
REVISED					

W12P4 CARRIER TAPE DIMENSION

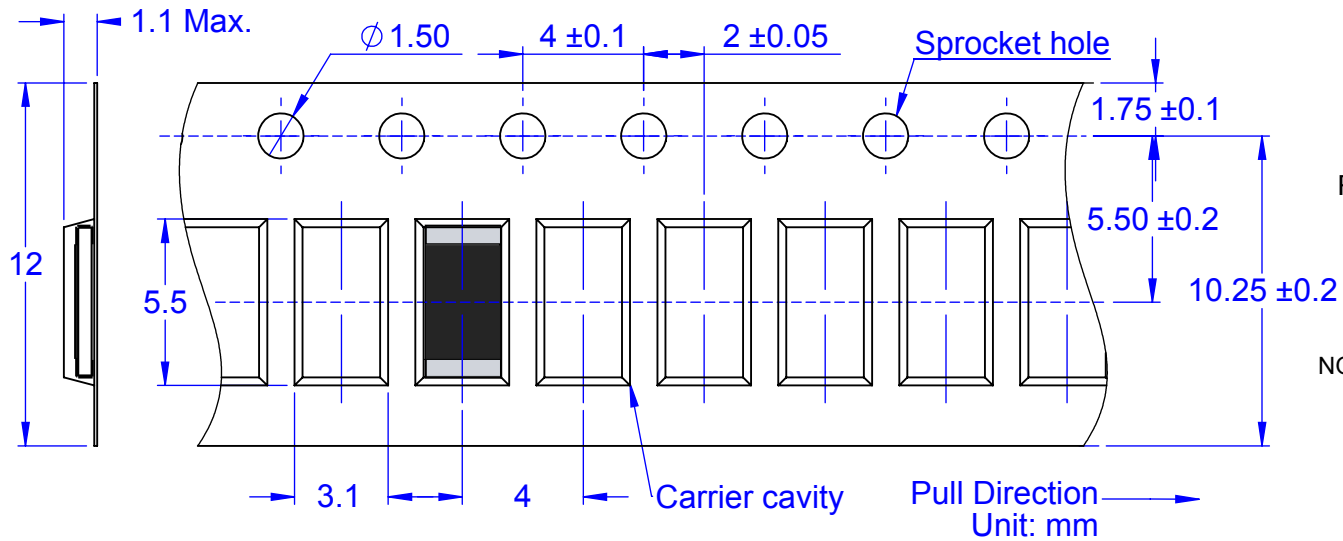

PART NUMBER SYSTEM

SR 2010 E7A - ZERO - T

RESISTOR PACK CODE < 50m Ω

SIZE CODE TERMINATION
 5.0 x 2.5mm Sn (TIN)

NOTE: For dummy resistor replace ZERO with blank

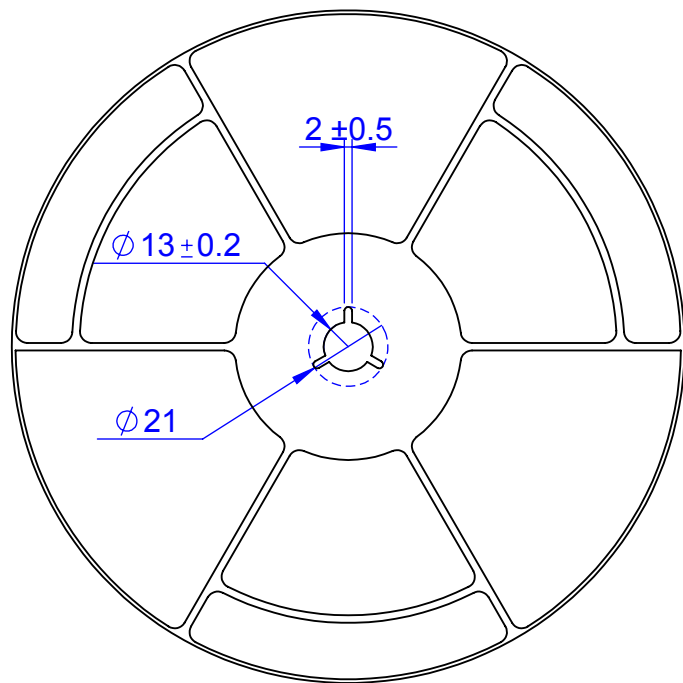

REEL DIMENSIONS

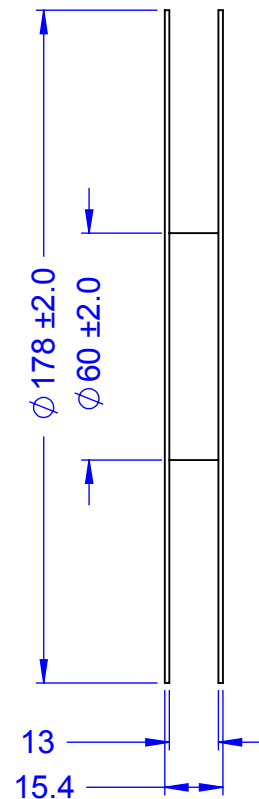

PACK CODE		
*CODE	QTY	PACKAGE
E7A	4,000	REEL
E4A	250	REEL

APPROVALS	DATE				
DRAWN T. Au	08/03/12				
ENG M. Hart	08/03/12	TITLE SR2010 SMT RESISTOR			
MFG		SCALE	SIZE A	DRAWING NO.	REV
QA				122012	A
CUST		DO NOT SCALE DRAWING			SHEET 2 OF 2
REVISED					