

HCD

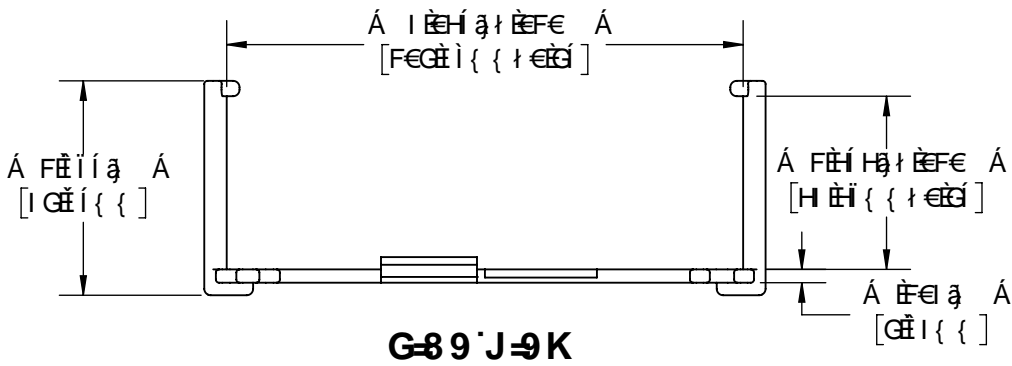

G89 J-9K

6 CHCA

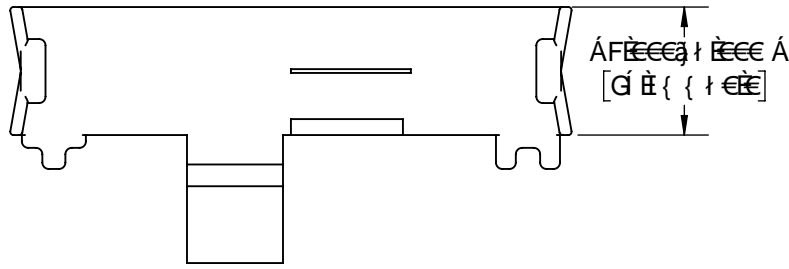
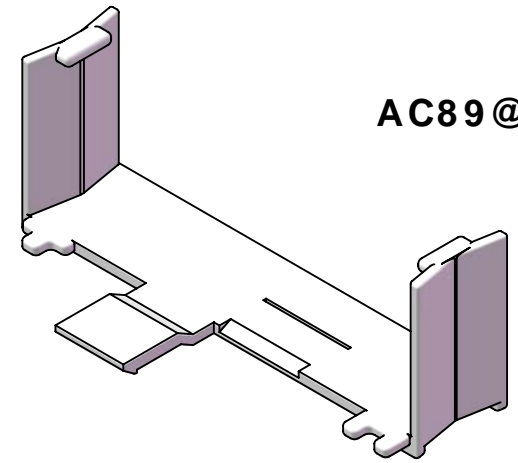
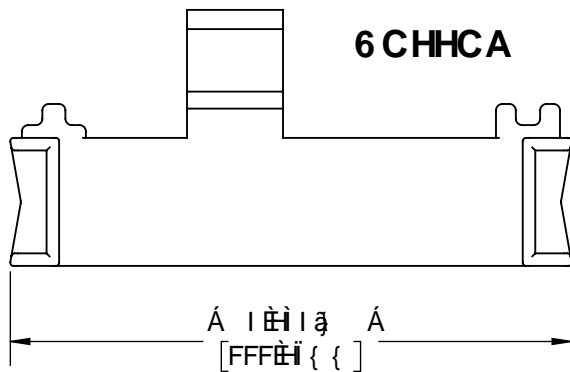

AC89@

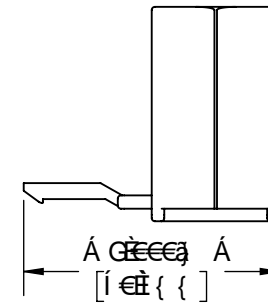

98; 9 J-9K

D5 FH'BI A 69 F'H56 @			
D5 FH'B6 F	7 C@CF	Gi fZMW FYglhj]hm C\ a g"GE"	F9:
Y ÚI EÖŠŰÍ EÞ	ÞCÆ/WÜCŠ	NFE ^{FG}	FÍ HÍ Ĩ F
Y ÚI EÖŠŰÍ EÖ	ÓŠCÖS	FÉ ^H dFÉ ^J	€ Í FEG

ΡΟΥΟΥΚ
 FÉÚCZÓPÓPÄ { Æ
 GÄT CÆ/ÖÜCŠKÚŠYÚUUÚYŠÖÞ ÖE
 HÉVY UÁÖŠÖUÁÖÜWÖÖÁJÖUÁÖÜÜÖT ÖŠYÉ
 I EÞUŠÖUÁUÖÖNPÖÜÁ cÁ/ÜCÆ/ÜÄg a Fc/ÖUXÖÜÈ

ÖÜÜÜXÖŠÜ	ÖCÆ/Ö				
ÖÜCÆ Þ/ÄÄÄ VÍE	FÉBFBÖE	VÖŠÖ Y ÚI EÖŠŰÍ Í cÁ/ÜCÆ/ÜÄÖUXÖÜ			
ÖÞÖ T EÞ æc	FÉBFBÖE				
T ÖÖ		ÜCÆÖ GHI	ÜCÆ CE	ÖÜCÆ ÖÖÄÜE FI €€FI	ÜÖX CE
ÜÖXÖÖÖ		ÖÜÄÜVÁÜCÆÖÖÜCÆ ÖÖ		ÜPÖÖV/ÆÁÜZÁ	

HK C 7 @D'5 GG9 A 6 @M

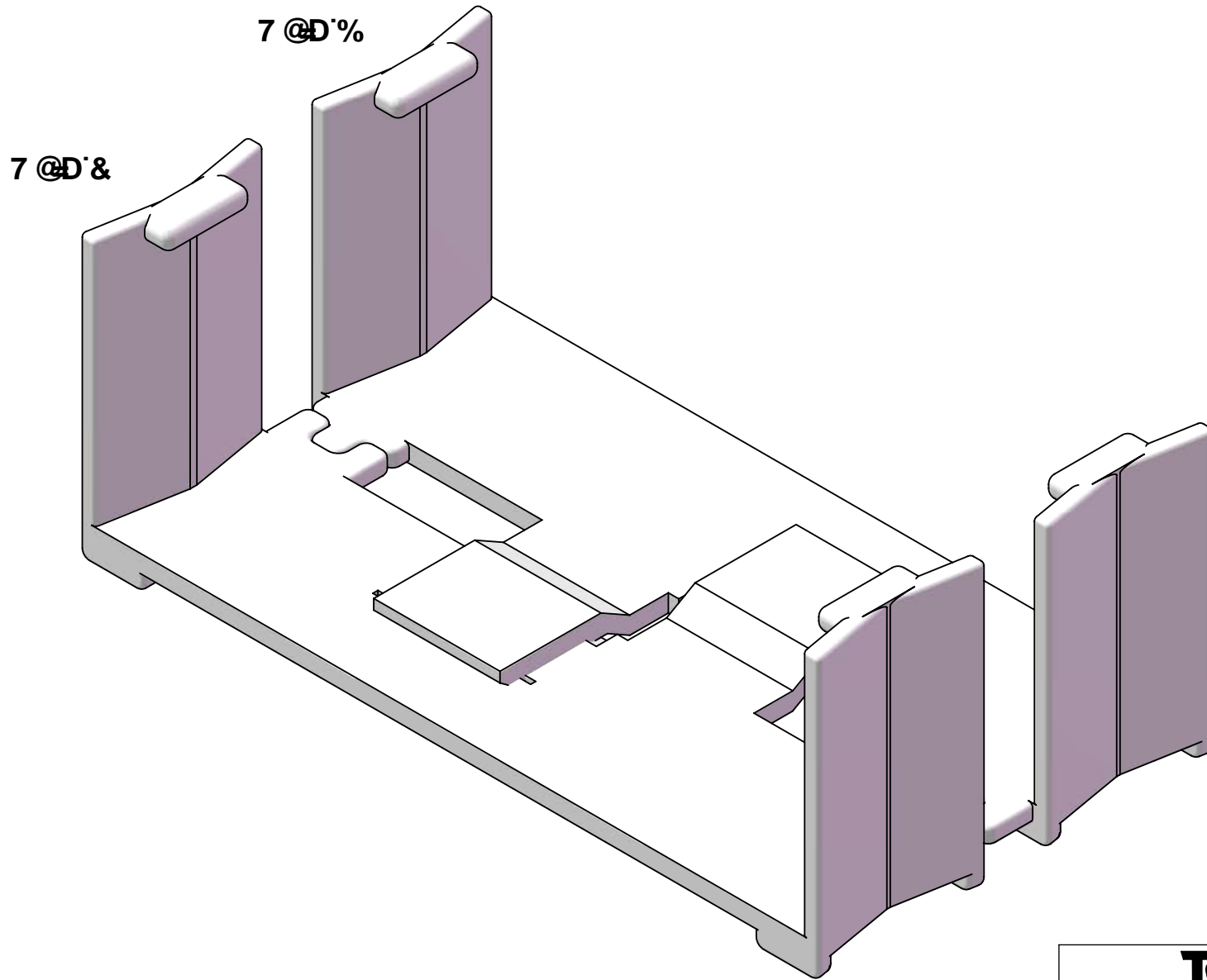

ΒΥΝΘΪΚ
 ΕΞΥ ΠΑΡΟΧΗ ΤΟΥ ΠΡΟΑΪΟΥ ΑΠΟ ΤΟ ΣΥΣΤΗΜΑ
 ΓΕΡΜΑΝΙΚΗΣ ΠΡΟΒΛΕΨΗΣ ΚΑΙ ΑΣΦΑΛΕΙΑΣ

TopLine[®]			
ΥΠΟΛΟΓΙΣΤΗΣ ΚΑΤΑΝΑΛΩΣΤΗΣ			
ΜΑΡΚΑ HK	ΧΡΩΜΑ CE	ΑΝΤΙΣΤΗΝΗ FI €€FI	ΎΨΟΣ CE
ΣΥΝΕΛΕΞΑΝΤΕΣ			ΠΡΟΒΛΕΨΗ

8K;`%\$\$\$\$
(7CJ9F

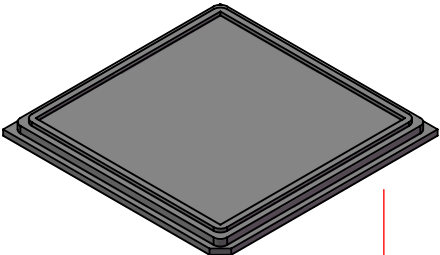

8K;`%\$\$\$\$%
@B9F`G<99H

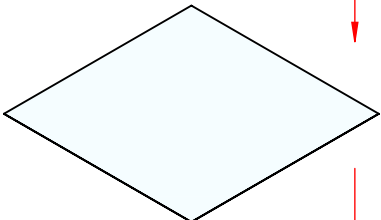

*1(`K5::@`HF5M

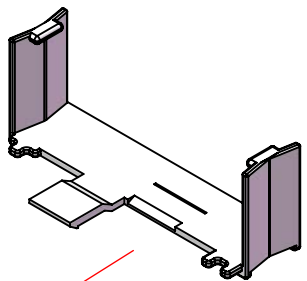
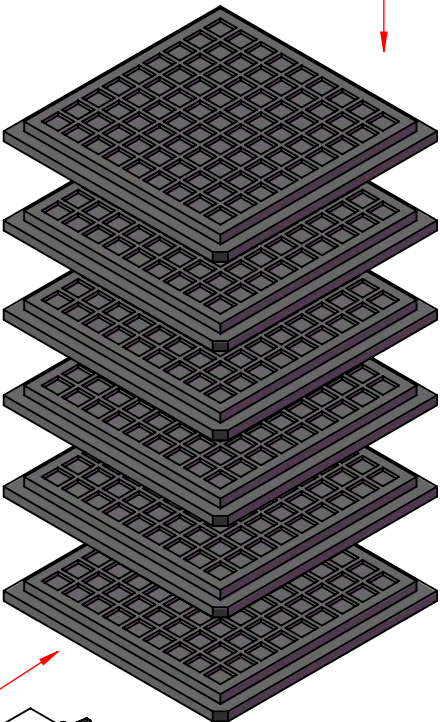

7 @D%

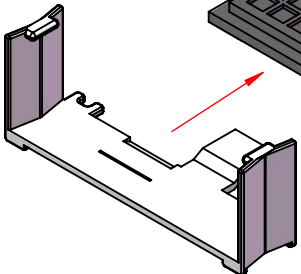

7 @D&

ΒΥΝΟΥΚ
FĚAVY UĀŌŠŌJĀŪŌUŌWŌŌŌĀŪŌUĀĈŪŪŌT ŌŠYĚ
GĚPUSŌŪĀUŌŌNPŌŪĀ ĉĀVŪĈYŪĀĝ ĀFĀŌUXŌUĚ

TopLine®

varšō Y ÚĪ ĘŌŠŪĪ
ĪĉĀVŪĈYŪĀĈUXŌU

ŪŌĉŌŠŌ FKĚ	ŪĀŌ ĈE	ŪŪĀY @ŌĀUE FI €FI	ŪŌX ĈE
---------------	-----------	----------------------	-----------

ŪŪĀPŪVĀŪŌĈŌŠŌŪŪĈY @Ō ŪŪŌVĀĤĪŪĀĪ

5 GG9 A 6 @MK #K * I 'HF5 MG'5 B8 '% '7 CJ9F
 HCD'J-9K

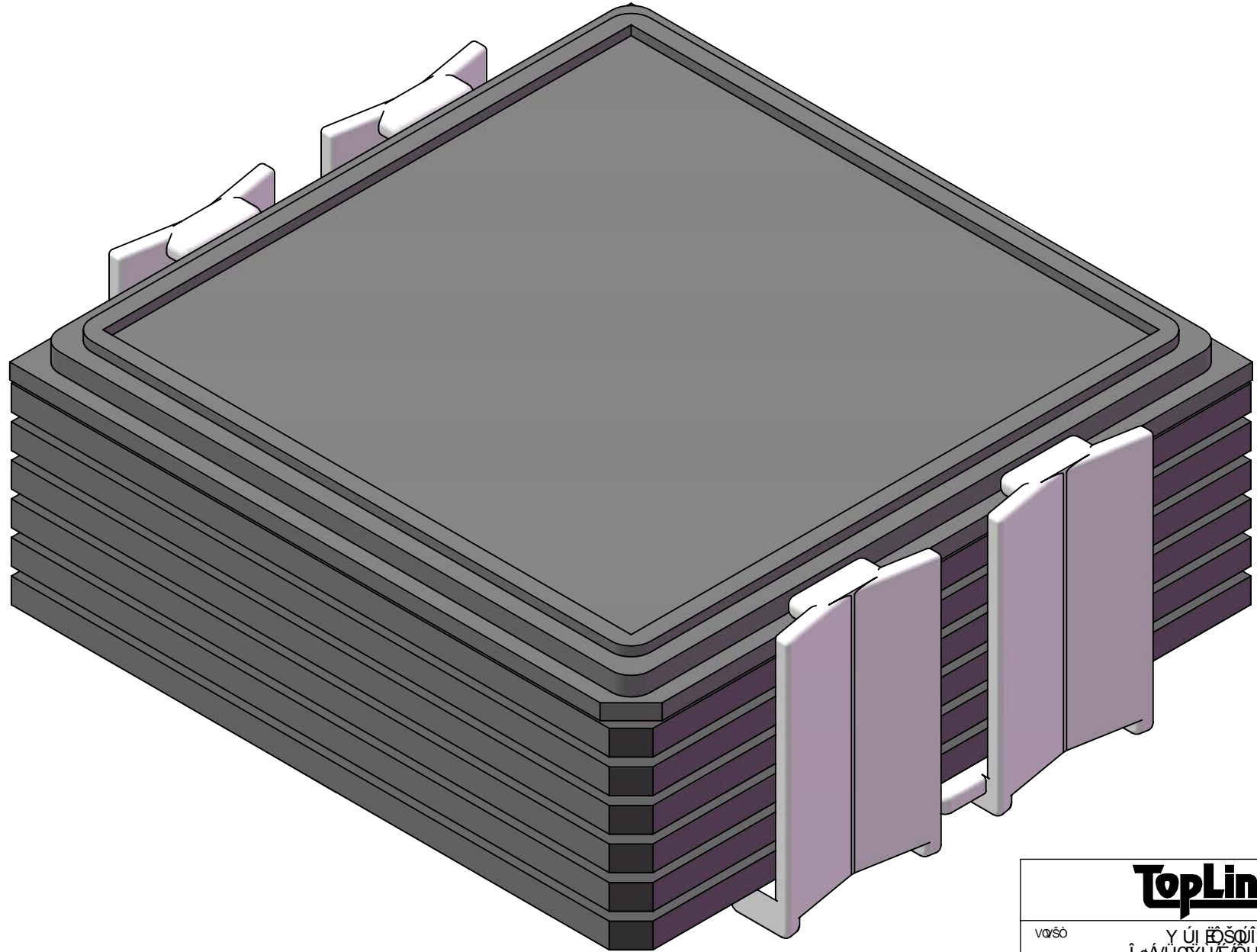

ΒΥΝΘΥΚ
 FĚVY UĀŌŠŌĀĴŌŪWŌŪŌŌĀĴŌŪĀŒŪŪŌŦ ŌŠŸĚ
 GĚPUSŌŪĀUŌŌŦPŌŪĀ ĆĀŪŒŸŪĀġ ĀĀĀŒŌUXŌŪĚ

TopLine®			
vαřšŌ		Y ŪĴ ĚŌŠŪĴ Ī ĆĀŪŒŸŪĀĒŪXŌŪ	
ŪŌŒŠŌ	ŪĀŌ	ŌŪŒŸ ŌŌĀŪĚ	ŪŌX
HG	ŒĚ	FI ĚĚĴĴ	ŒĚ
ŌŪĀŪVĀŪŌŒŠŌŌŪŒŸ ŌŌŌ			ŪPŌŌVĀĀŪŒĀ

5 GG9 A 6 @MK #K *I 'HF5 MG'5 B8 '% 7 CJ9F
 6 CHCA J9K

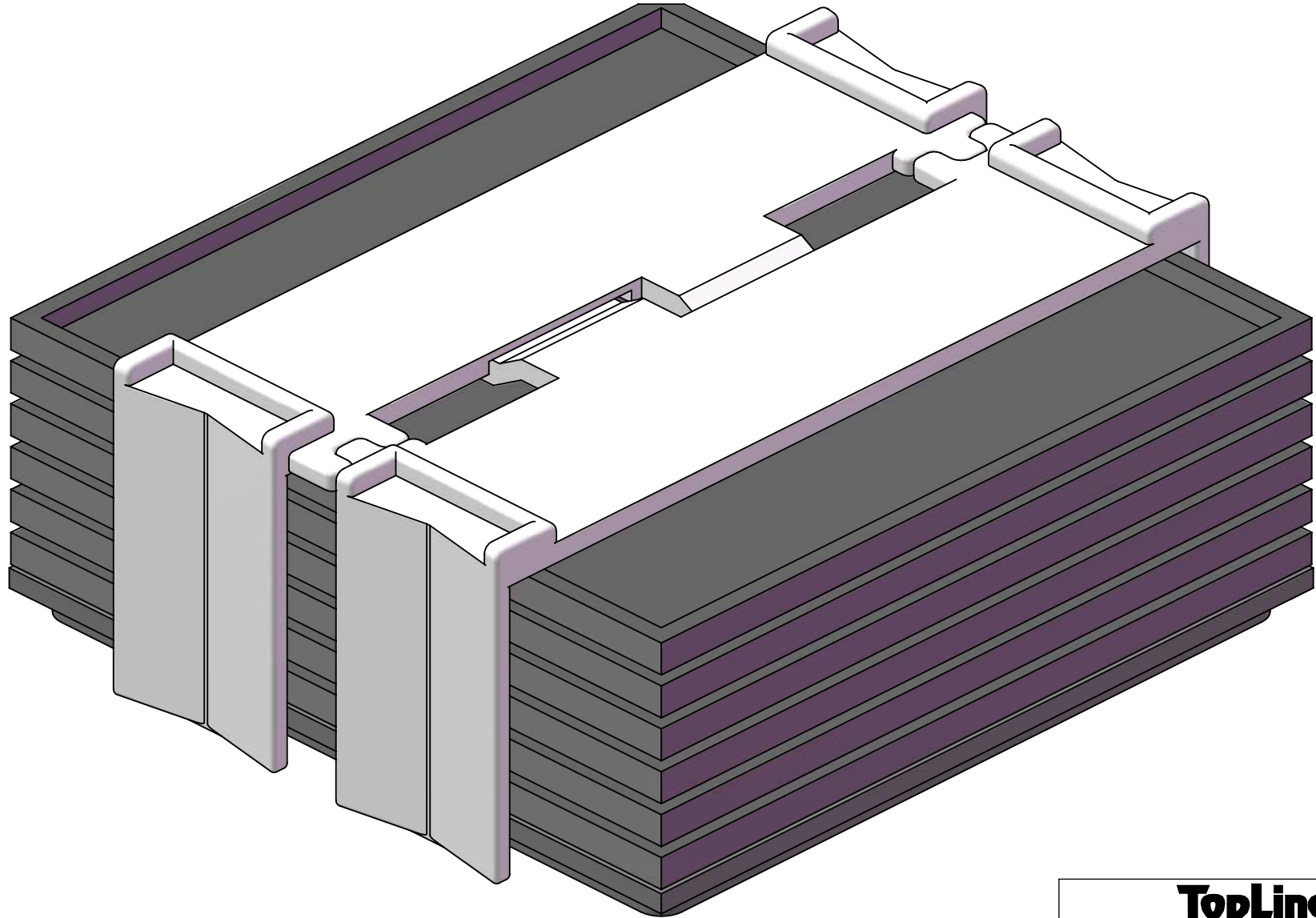

БУВЌУК
 FĚVY UĀŌŠŌĀJŌUŌWŌŌŌĀJŌUĀŌŌUŌŌT ŌŠŸĚ
 GĚPUSŌŪĀUŌŌŌVPŌŪĀ ĆĀŪŌŸŪĀĚ ĆĀŌŪŌUXŌŪĚ

TopLine®			
varšò		Y ŪI ĚŠŌŪĪ Ī ĆĀŪŌŸŪĀĚŌUXŌŪ	
ŪŌŌŠŌ	ŪŌŌ	ŌŪŌŸ ŌŌŌŪĚ	ŪŌX
HG	ŌĚ	FI ĚĚFI	ŌĚ
ŌŪŌŪVĀŪŌŌŠŌŌŪŌŸŪŌŌ			ŪPŌŌVĀĀŪŌĀ