

HCDJ9K
6I AD5FF5M* &I * &

85-GM7<5-B

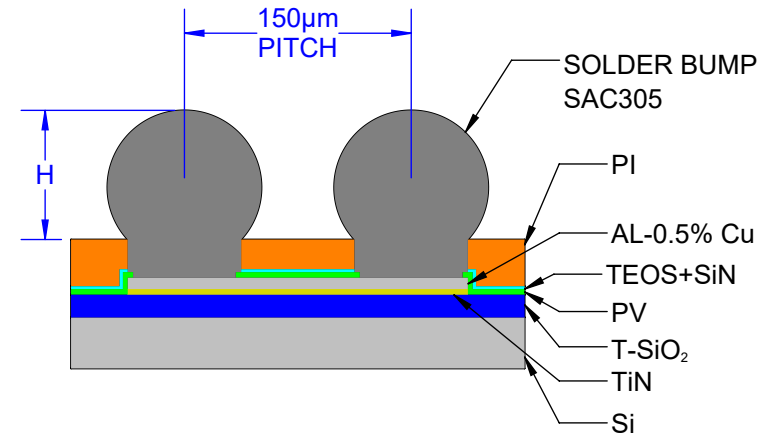
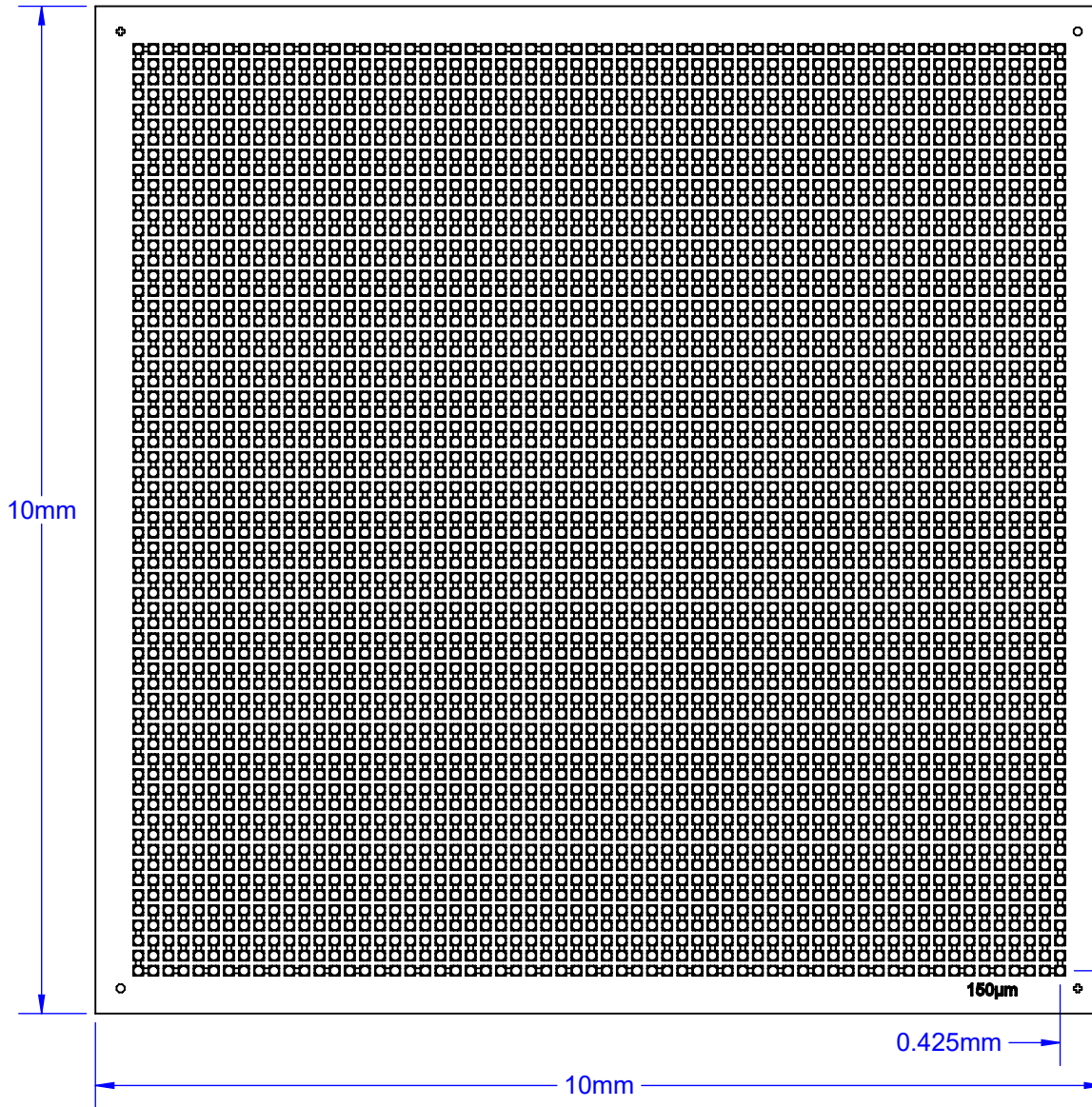

6I AD8-A9BG-CBGH56 @		
H	BUMP HEIGHT	65µm
SAC305	BUMP DIA	∅92µm

WAFER 200mm (8-INCH)
DICING STREET 10 x 10mm
DIE SIZE AFTER DICING 9.96 x 9.96mm
BUMPS 3844

APPROVALS	DATE	TopLine®			
DRAWN T.Au	6/18/2021				
ENG M. Hart	6/18/2021	TITLE FC3844 - PITCH 150µm DAISY CHAIN FLIP CHIP			
MFG		SCALE	SIZE	DRAWING NO.	REV
QA		14:1	A	330620	A
CUST		DO NOT SCALE DRAWING			SHEET 1 OF 7
REVISED					

85 GM7 < 5 B D5 8 J 9 K

61 59 57 55 53 51 49 47 45 43 41 39 37 35 33 31 29 27 25 23 21 19 17 15 13 11 9 7 5 3 1
 62 60 58 56 54 52 50 48 46 44 42 40 38 36 34 32 30 28 26 24 22 20 18 16 14 12 10 8 6 4 2

A
B
C
D
E
F
G
H
J
K
L
M
N
P
R
T
U
V
W
Y
AA
AB
AC
AD
AE
AF
AG
AH
AJ
AK
AL
AM
AN
AP
AR
AT
AU
AV
AW
AY
BA
BB
BC
BD
BE
BF
BG
BH
BJ
BK
BL
BM
BN
BP
BR
BT
BU
BV
BW
BY
CA
CB

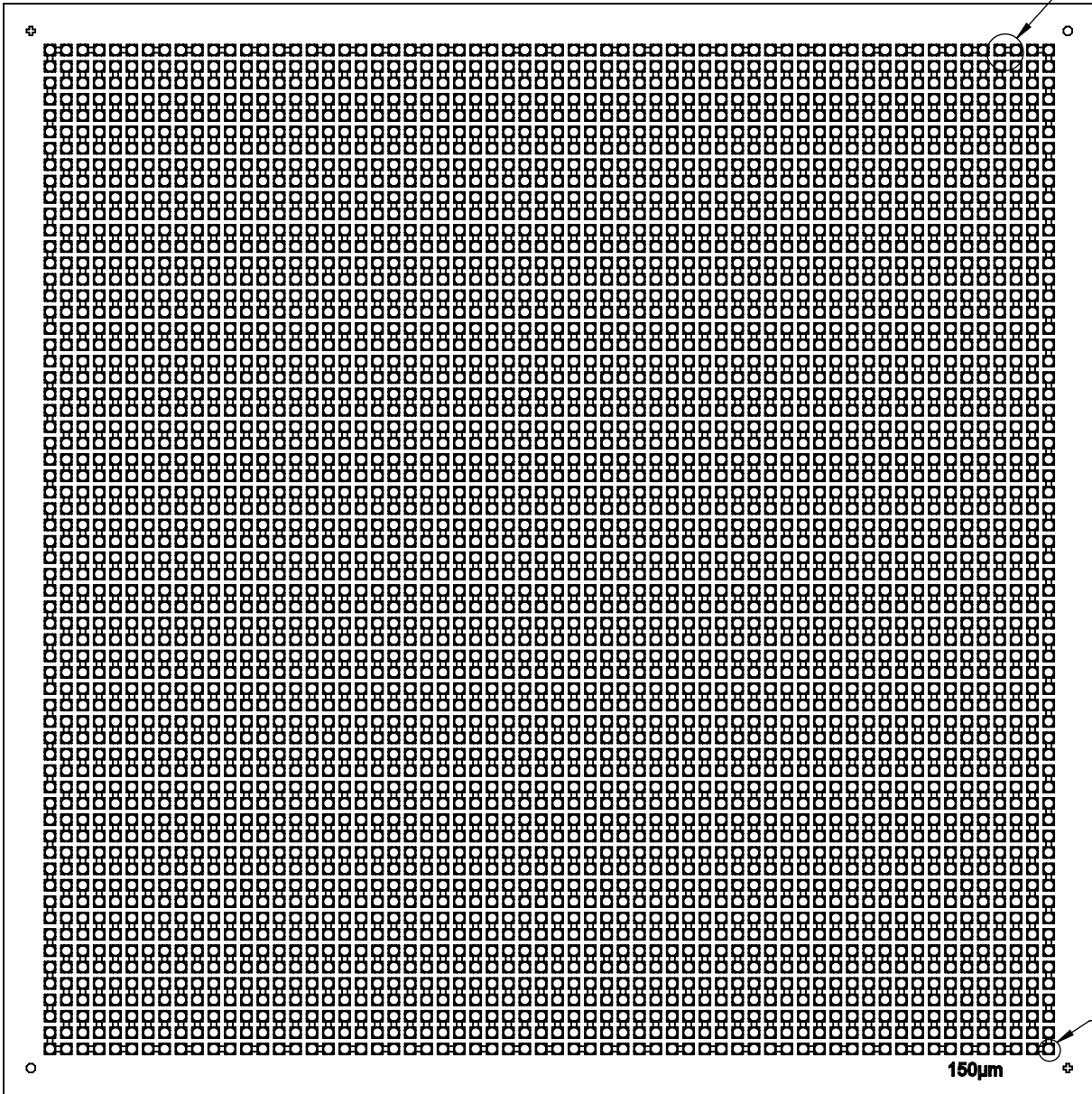

SEE DETAIL A

8 9 H5 = @ 5
 GC @ 9 F 6 I A D 5 8
 G7 5 @ \$\$\$. %

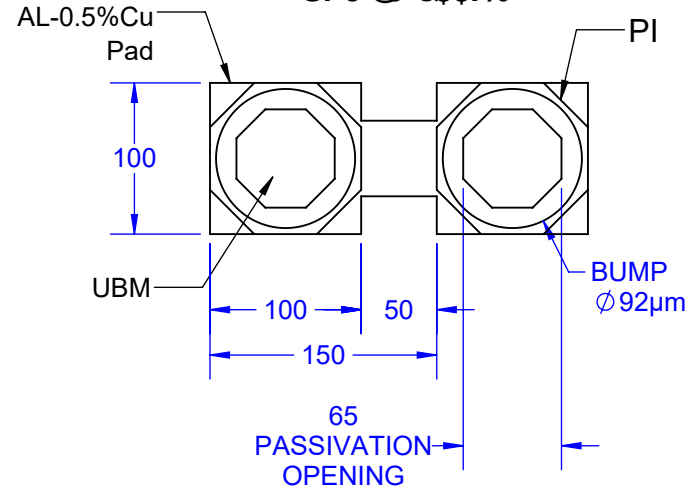

D5 GG J 5 H C B C D 9 B B ;
 G7 5 @ \$\$\$. %

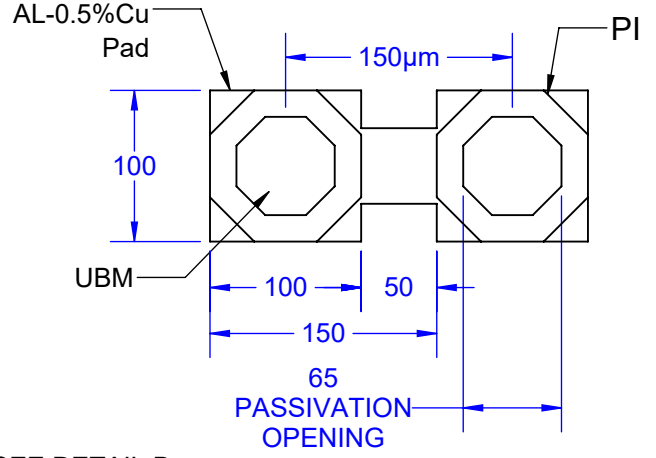

SEE DETAIL B

TopLine®			
TITLE FC3844 - PITCH 150µm DAISY CHAIN FLIP CHIP			
SCALE	SIZE	DRAWING NO.	REV
16:1	A	330620	A
DO NOT SCALE DRAWING			SHEET 2 OF 7

NOTES: (UNLES OTHERWISE SPECIFIED)
 1) DIMENSIONS: µm (MICRON).

89H5=@6"
: 8175@

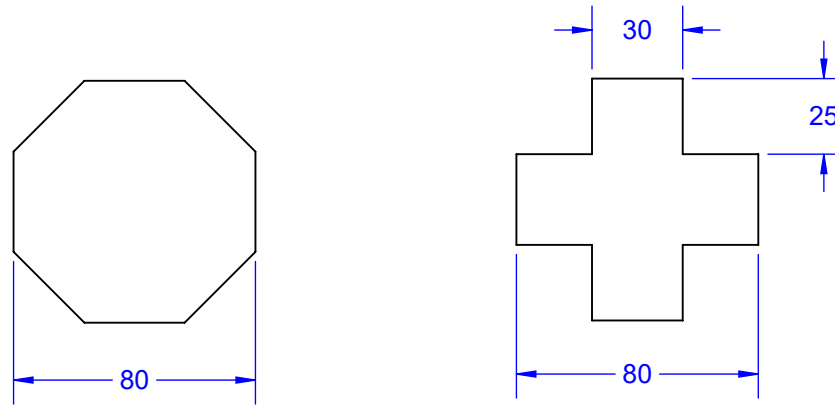

I 6 A 'D58 '89H5=@

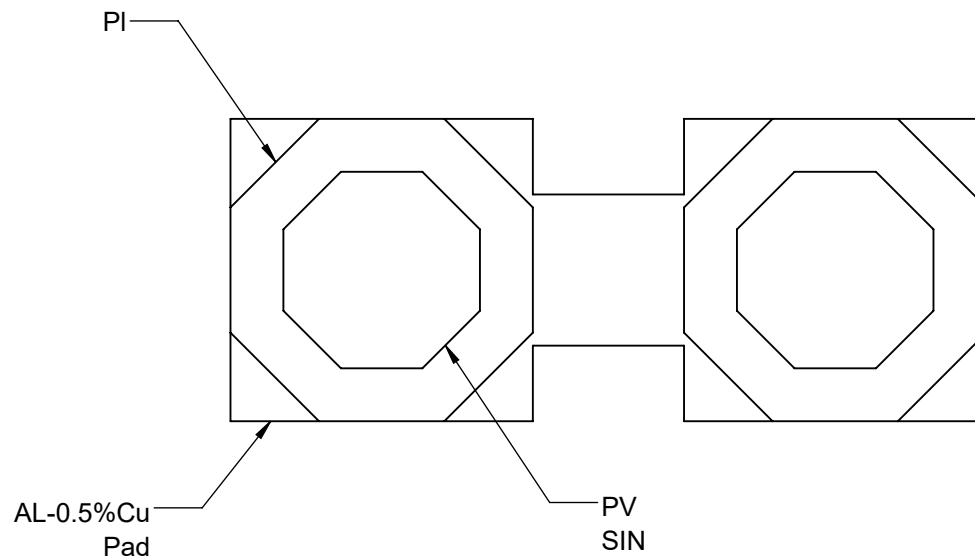

NOTES: (UNLES OTHERWISE SPECIFIED)
1) DIMENSIONS: μm (MICRON).

TopLine[®]			
TITLE FC3844 - PITCH 150 μm DAISY CHAIN FLIP CHIP			
SCALE 400:1	SIZE A	DRAWING NO. 330620	REV A
DO NOT SCALE DRAWING			SHEET 3 OF 7

A5H9F5 @G5B87CBGHFI7HCB

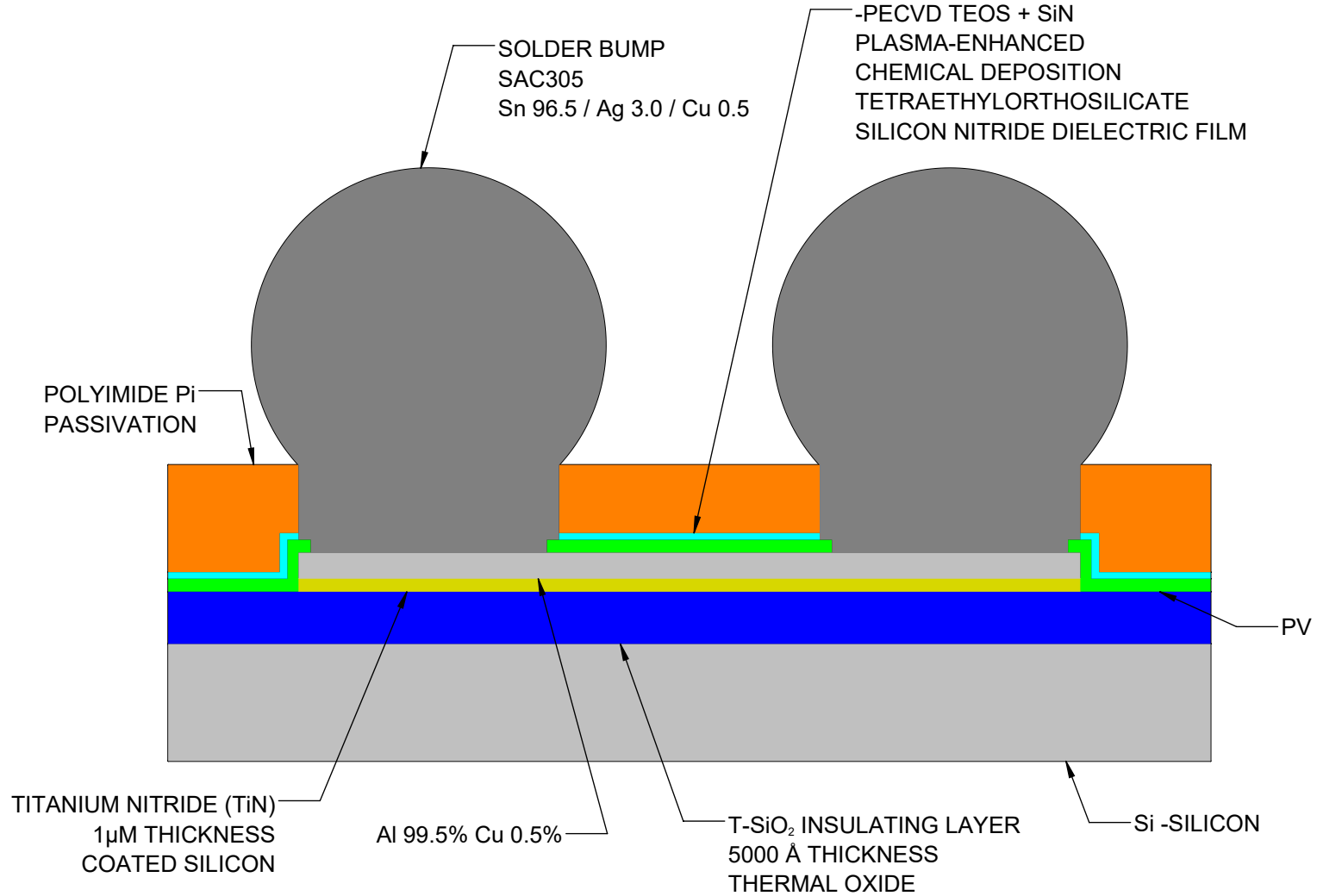

TopLine[®]			
TITLE FC3844 - PITCH 150µm DAISY CHAIN FLIP CHIP			
SCALE 400:1	SIZE A	DRAWING NO. 330620	REV A
DO NOT SCALE DRAWING		SHEET 4 OF 7	

D58 @C75 HCB
G<CKB'6I AD'J9K
8=A9BG-CBG-B'A7FCB'fl AL

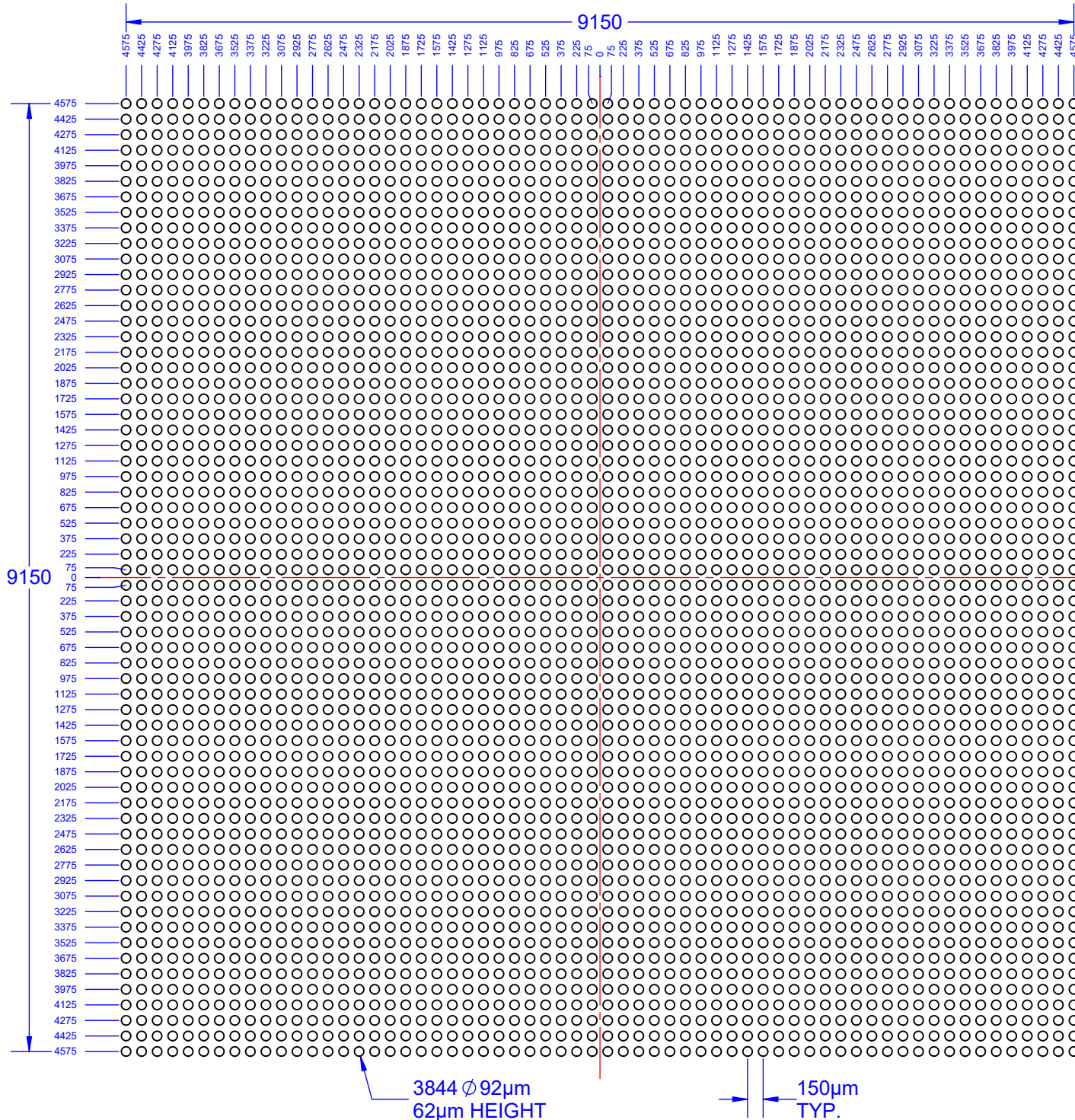

150µm
TYP.

3844 Ø92µm
62µm HEIGHT

150µm
TYP.

TopLine®			
TITLE FC3844 - PITCH 150µm DAISY CHAIN FLIP CHIP			
SCALE	SIZE	DRAWING NO.	REV
18:1	A	330620	A
DO NOT SCALE DRAWING			SHEET 5 OF 7

8 7 B;
 8 A9BG-CBG-B'A 7 FCB'fl A L

' , (('6I AD!'%I %\$AA

%)' +* '6I AD!'&\$I &\$AA

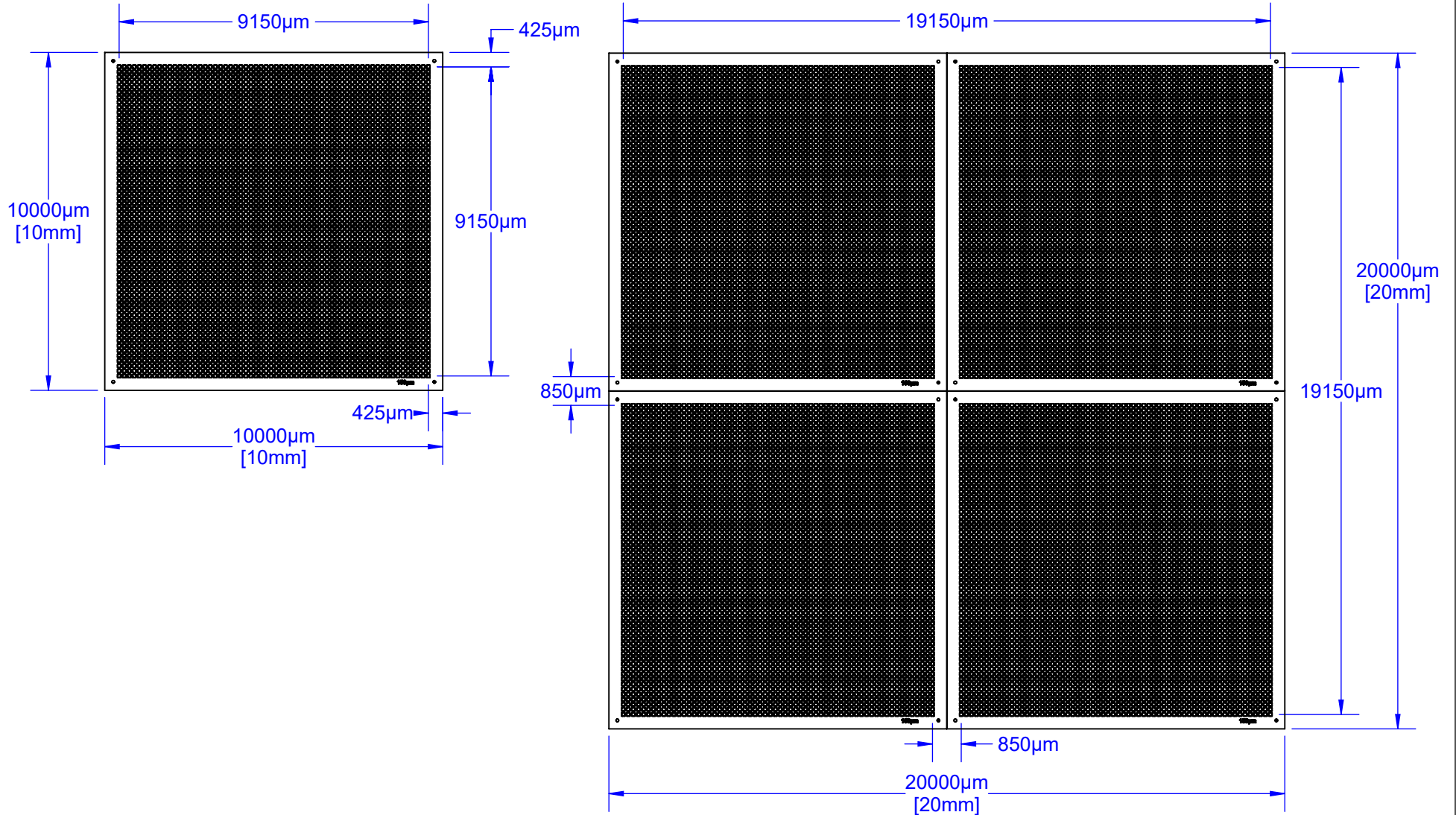

TopLine®			
TITLE FC3844 - PITCH 150μm DAISY CHAIN FLIP CHIP			
SCALE 6:1	SIZE A	DRAWING NO. 330620	REV A
DO NOT SCALE DRAWING		SHEET 6 OF 9	

D5 FH'BI A69F-B; 'GMGH9A

: @D7 < D

FC = STANDARD FLIP CHIP
 FCW = BUMPED WAFER*
 FCN = BUMPLESS CHIP
 FCWN = BUMPLESS WAFER*

*200MM WAFER

BI A69F'C: '6I ADG

3844 10x10mm
 15376 20x20mm

6I AD'8 5A9H9F

DIAMETER ϕ 92 μ m
 HEIGHT 65 μ m

8 9 'G=N9

BUMP MM
 3844 10x10mm
 15376 20x20mm

6I AD'A5H9F 5 @

C = LEAD FREE SAC305
 A = AL PAD (BUMPLESS)
 G = NiAu UBM (BUMPLESS)

6I AD'D=H7 <

μ M

8 9 'H<=BB-B;

CODE	μ M	INCH
NONE	725 μ m	.0285"
BG430	430 μ m	.017"
BG360	360 μ m	.014"
BG250	250 μ m	.010"
BG200	200 μ m	.008"
BG150	150 μ m	.006"
BG100	100 μ m	.004"

Other Thickness Available

85 =GM7 < 5 =B;

CDH=CBG

BLANK = TRAY (STANDARD)

BUMP	TRAY	QTY
3844	4-INCH	49 PCS
15376	4-INCH	9 PCS

G = GEL-PAK
 UV = WAFER RING
 C = CASSETTE (UNSAWN)
 J = WAFER CARRIER (UNSAWN)

TopLine[®]			
TITLE FC3844 - PITCH 150 μ m DAISY CHAIN FLIP CHIP			
SCALE NONE	SIZE A	DRAWING NO. 330620	REV A
DO NOT SCALE DRAWING			SHEET 7 OF 7