

**TOP**

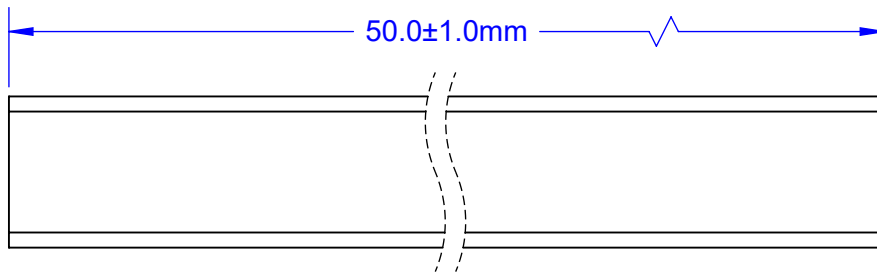

**FRONT**

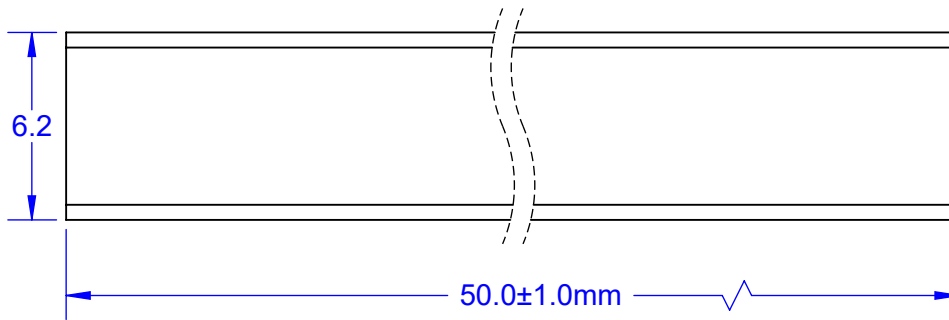

**MODELS**

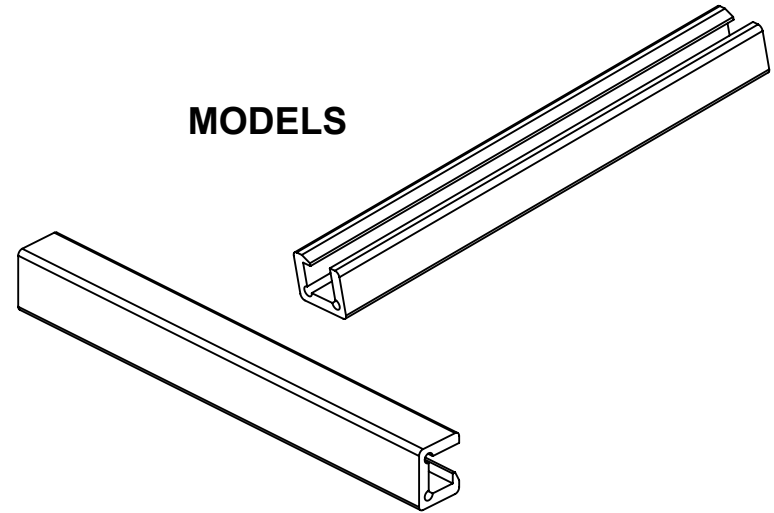

**END**

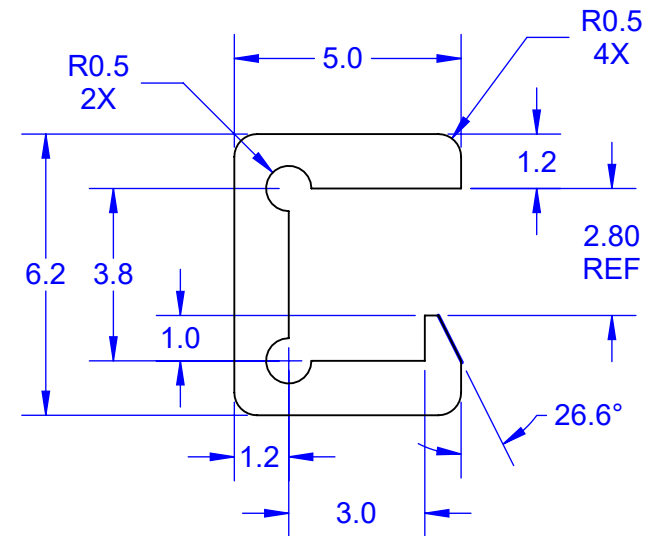

PART #	COLOR	PANTONE	RGB
127001	WHITE	1122	FFFFFF
127002	GREEN	347C	009B48
127003	BLUE	300C	65B2FF
127005	ORANGE	151C	FF6A00
127006	PURPLE	258U	93509E
127007	GOLD	1245C	C59217
127009	RED	7427C	96172E
127012	YELLOW	12-0740-TPX	F3ED7C
127013	BLACK	3C	000000
127015	LIGHT GRAY	401C	CCCCCC
127016	BROWN	463U	6C4D23

Notes: (Unless Otherwise Specified).

- 1) DIMENSIONS: MM.
- 2) MATERIAL: ANTI-STATIC NYLON.
- 3) SURFACE RESISTANCE/SQUARE  $10^9 \sim 10^{11}$  OHMS.
- 4) BAKE OUT TEMPERATURE 125°C MAXIMUM.

APPROVALS	DATE				
DRAWN T. Au	12/23/2023				
ENG M. Hart	12/23/2023	TITLE COLOR TRAY CLIPS (2-INCH) 127001 TO 127016			
MFG		SCALE	SIZE	DRAWING NO.	REV
QA		4:1	A	127000	B
CUST		DO NOT SCALE DRAWING			SHEET 1 OF 2
REVISED					

# CUSTOM CLIP MARKING QUESTIONNAIRE

Date \_\_\_\_\_

Contact \_\_\_\_\_ Title \_\_\_\_\_

Company \_\_\_\_\_ Tel \_\_\_\_\_

Project # \_\_\_\_\_ email \_\_\_\_\_

A. CLIP SIZE:       25mm (1.0-inch)       50mm (2.0-inch)       OTHER: \_\_\_\_\_

B. COLOR: \_\_\_\_\_ C. TOPLINE CLIP# \_\_\_\_\_ D. Max Bake Temp \_\_\_\_\_ °C

E. HORIZONTAL POSITIONING OF TEXT ON CLIP:       CENTER       LEFT       RIGHT

F. MARK

1	2	3	4	5	6	7	8	9	10	11	12	13	14	15	16	

G. Usage Forecast:      First Time: \_\_\_\_\_      Estimated Annual Usage \_\_\_\_\_

H. Clip will be used on this JEDEC TRAY:       Tray Drawing Attached

Tray Brand \_\_\_\_\_ Tray Part# \_\_\_\_\_

Return completed questionnaire to TopLine email: [sales@TopLine.tv](mailto:sales@TopLine.tv)

<b>TopLine<sup>®</sup></b>			
TITLE    COLOR TRAY CLIPS (2-INCH) 127001 TO 127016			
SCALE NONE	SIZE A	DRAWING NO. 127000	REV A
DO NOT SCALE DRAWING			SHEET 2 OF 2