

# 6CHCA J9K

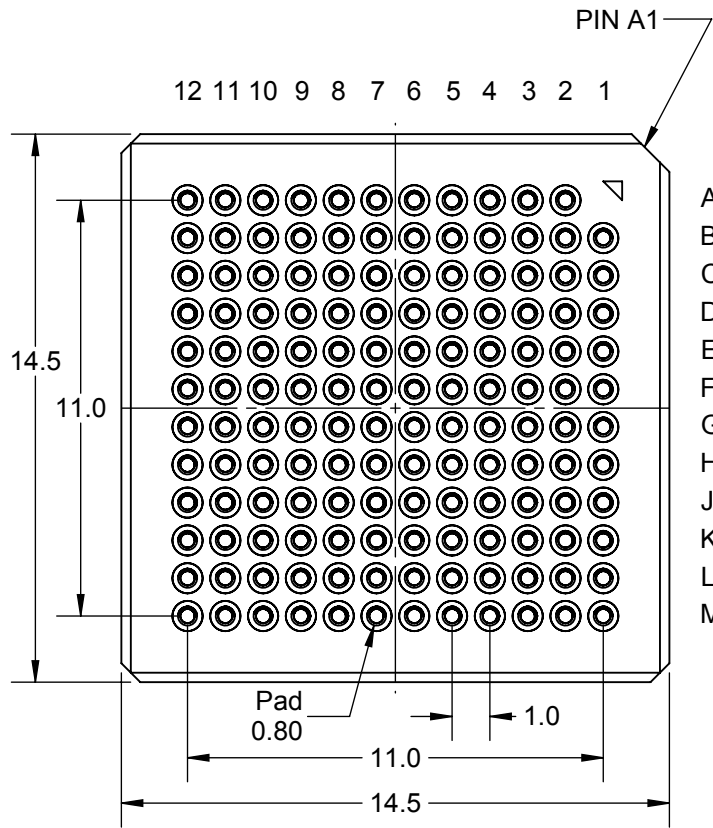

# G89 J9K

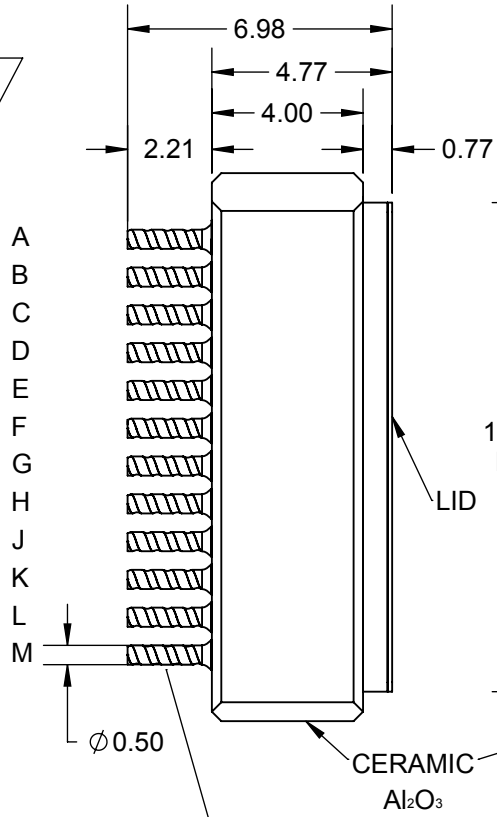

# HCD J9K

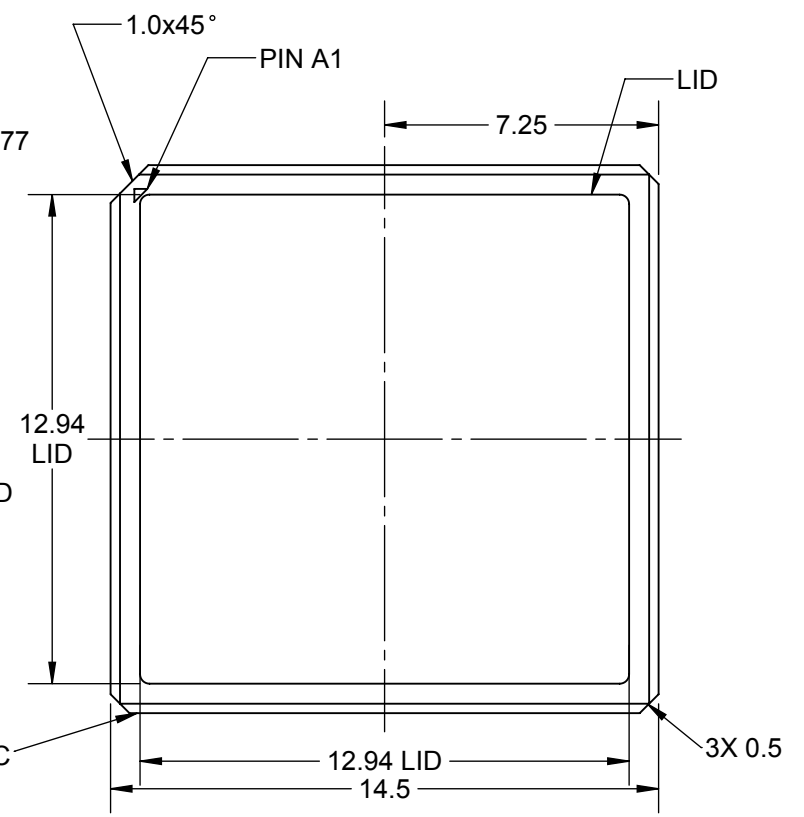

GC @ 9F 7C @ AB  
DV, \$G@ \$7i 'K F5D

**NOTES:**

1. MATERIAL IS 90%-MINIMUM ALUMINA.
2. UNITS ARE MILLIMETERS.
3. LID IS CONNECTED TO VSS.
4. EXPOSED-METAL PLATING PER MIL-PRF-38535.
  - a. NICKEL BASE: ELECTRO-PLATED 2.54~8.89µm.
  - b. GOLD: ELECTRO-PLATED 2.54~5.72µm.

**Notes: (Unless Otherwise Specified).**

- 1) DIMENSIONS ARE IN mm.
- 2) SHOWN WITH COLUMNS.
- 3) SHOWN WITH LID COVER ATTACHED.
- 4) PART NUMBER: CCGA143T1.0-12x12.

D5FHBI A69F CDHCBG			
D5FHBI A69F	8I AAM89	GC @ 9F D-B	@8
CCGA143T1.0-12x12	YES	YES	YES

APPROVALS	DATE	<b>TopLine®</b>		
DRAWN T.Au	8/6/2019			
ENG M. Hart	8/6/2019	TITLE CCGA143T1.0-12x12 COLUMN GRID ARRAY		
MFG		SCALE 3:1	SIZE A	DRAWING NO. 160020
QA				REV A
CUST				
REVISED		DO NOT SCALE DRAWING		SHEET 1 OF 5

### 6CHCA J9K

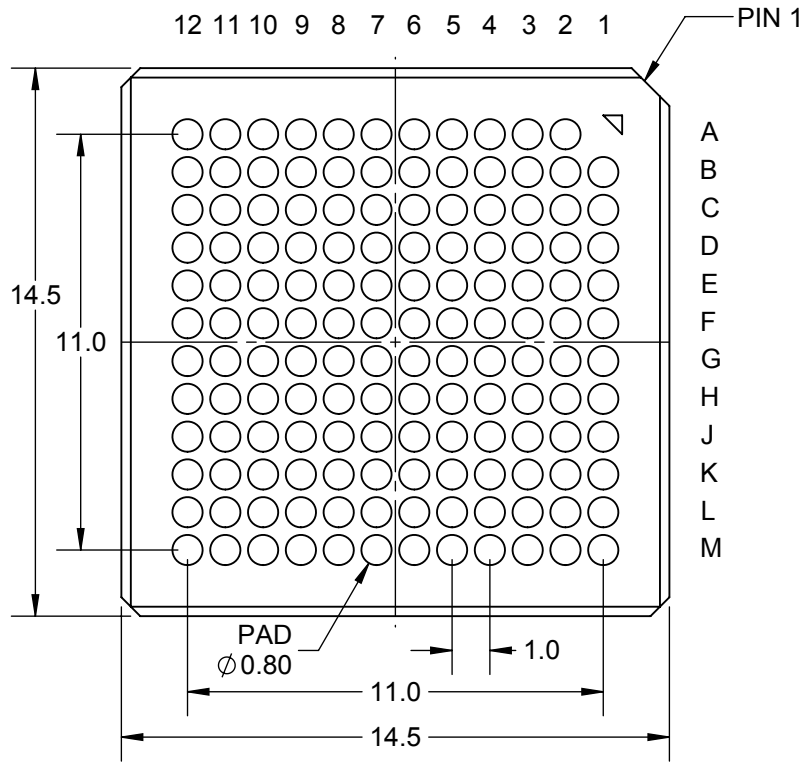

### G89 J9K

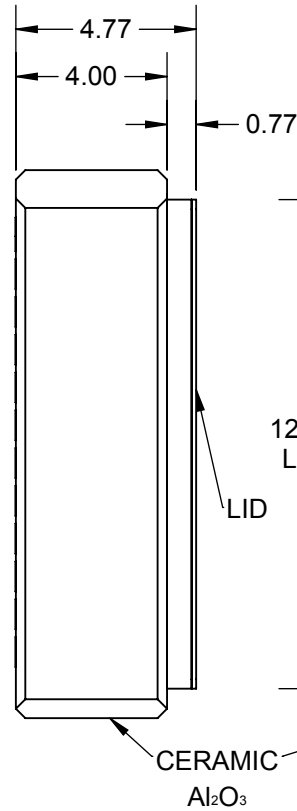

### HCD J9K

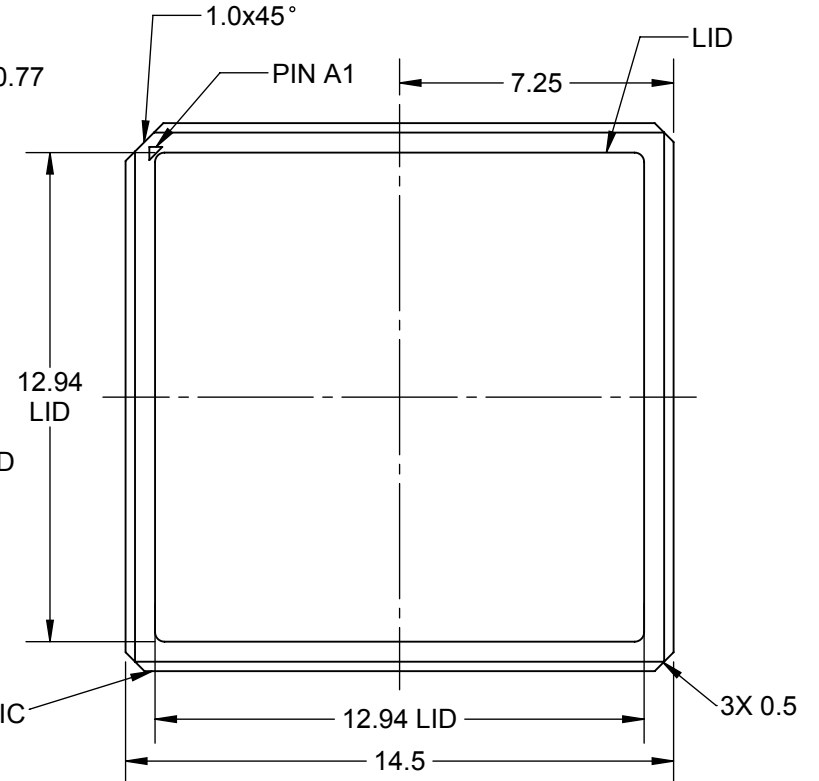

**NOTES:**

1. MATERIAL IS 90%-MINIMUM ALUMINA .
2. UNITS ARE MILLIMETERS.
3. LID IS CONNECTED TO VSS.
4. EXPOSED-METAL PLATING PER MIL-PRF-38535.
  - a. NICKEL BASE: ELECTRO-PLATED 2.54~8.89µm.
  - b. GOLD: ELECTRO-PLATED 2.54~5.72µm.

**Notes: (Unless Otherwise Specified).**

- 1) DIMENSIONS ARE IN mm.
- 2) SHOWN WITHOUT COLUMNS.
- 3) SHOWN WITH LID COVER ATTACHED.
- 4) PART NUMBER: CLGA143T1.0-12x12.

<b>D5FHBI A69F CDHCBG</b>			
<b>D5FHBI A69F</b>	<b>81AAM89</b>	<b>GC89FDB</b>	<b>@8</b>
CLGA143T1.0-12x12	YES	NO	YES

APPROVALS	DATE	<b>TopLine®</b>		
DRAWN T.Au	8/6/2019			
ENG M. Hart	8/6/2019	TITLE CCGA143T1.0-12x12 COLUMN GRID ARRAY		
MFG		SCALE 3:1	SIZE A	DRAWING NO. 160020
QA				REV A
CUST				
REVISED		DO NOT SCALE DRAWING		SHEET 2 OF 5

D5 8 'D5 HH9 FB

7 C @ AB 'f 5 @ @ L J - 9 K

6 CHHCA 'L!F5 M  
J - 9 K 9 8 : FCA 'HCD

12 11 10 9 8 7 6 5 4 3 2 1

1 2 3 4 5 6 7 8 9 10 11 12

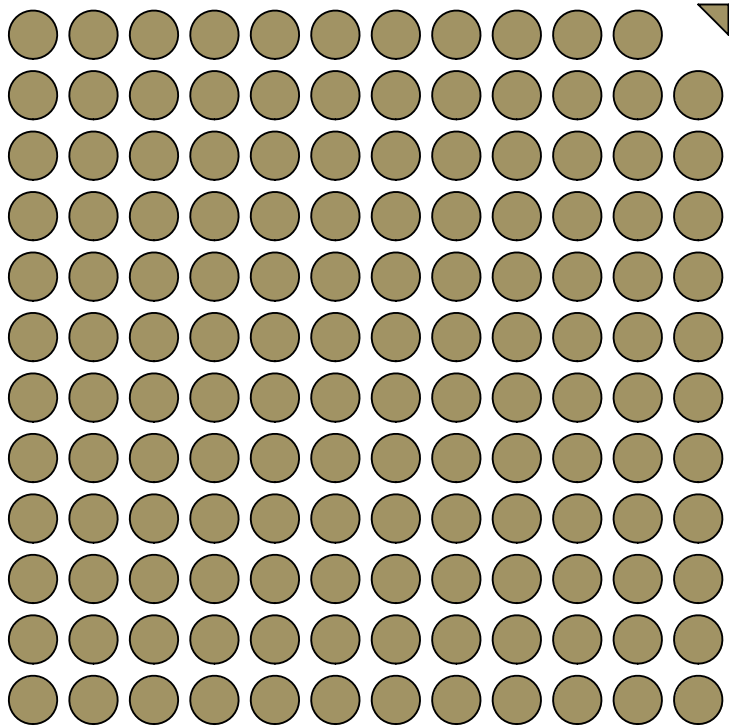

A  
B  
C  
D  
E  
F  
G  
H  
J  
K  
L  
M

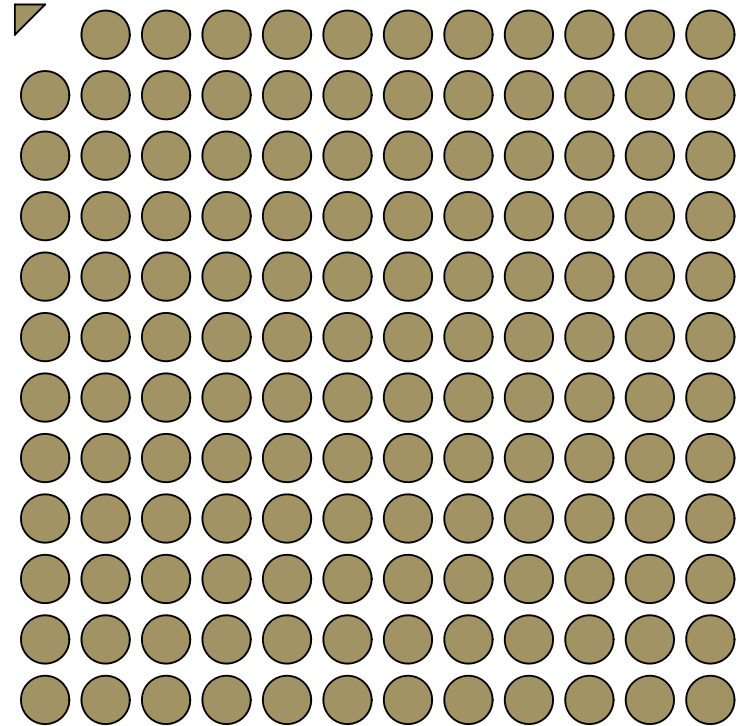

A  
B  
C  
D  
E  
F  
G  
H  
J  
K  
L  
M

**TopLine**<sup>®</sup>

TITLE CCGA143T1.0-12x12  
COLUMN GRID ARRAY

SCALE 8:1	SIZE A	DRAWING NO. 160020	REV A
--------------	-----------	-----------------------	----------

DO NOT SCALE DRAWING

SHEET 3 OF 5

AC89@  
7 @ 5%' H%\$!%& %&  
K#kCI H7C@ ABG

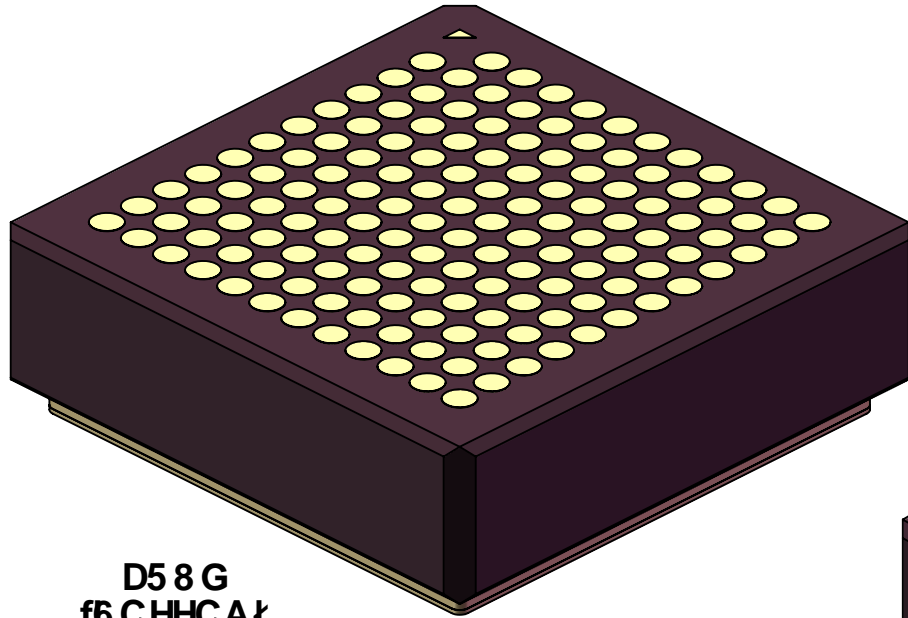

D5 8 G  
f6 CHHCAŁ

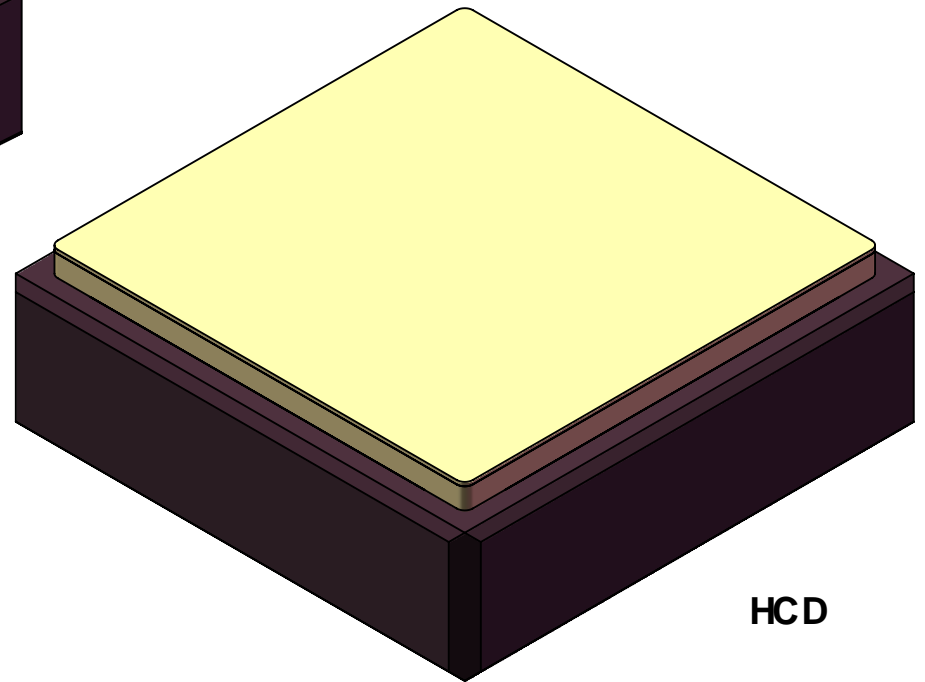

HCD

**TopLine**<sup>®</sup>

TITLE CCGA143T1.0-12x12  
COLUMN GRID ARRAY

SCALE 6:1	SIZE A	DRAWING NO. 160020	REV A
--------------	-----------	-----------------------	----------

DO NOT SCALE DRAWING

SHEET 4 OF 5

AC89@  
77; 5%' H%\$!%& %&  
K #K '7 C @ ABG

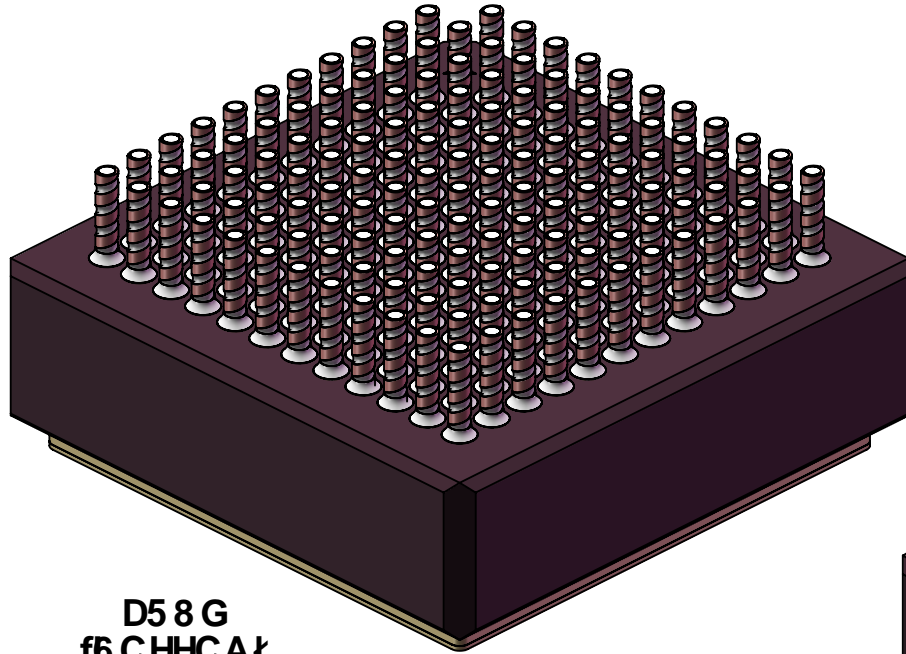

D58G  
f6 CHHCAŁ

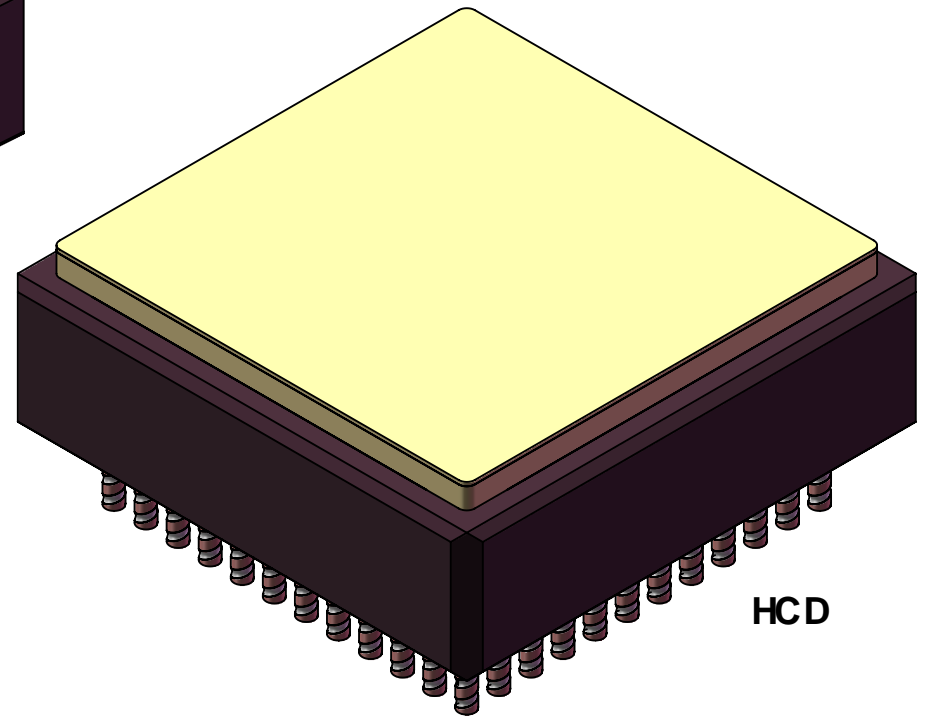

HCD

<b>TopLine®</b>			
TITLE		CCGA143T1.0-12x12 COLUMN GRID ARRAY	
SCALE	SIZE	DRAWING NO.	REV
6:1	A	160020	A
DO NOT SCALE DRAWING			SHEET 5 OF 5