

- Notes: (Unless Otherwise Specified).
- 1) DIMENSIONS: MM [INCH].
  - 2) FLAT LEADS ON ALLOY 42 TIE BAR.
  - 3) ALL EXPOSED METAL GOLD PLATED (Au).  
60 micro-inch thick gold.
  - 4) DIE PAD FLOOR IS BARE (No Au)

REF: QC-240314-WZ3

APPROVALS	DATE	<b>TopLine®</b>			
DRAWN T. Au	3/27/2023				
ENG M. Hart	3/27/2023	TITLE CERQUAD240G19.7-N660X BARE CAVITY			
MFG		SCALE	SIZE	DRAWING NO.	REV
QA		2.5:1	A	166287	A
CUST		DO NOT SCALE DRAWING			SHEET 1 OF 6
REVISED					

# BONDING DIAGRAM

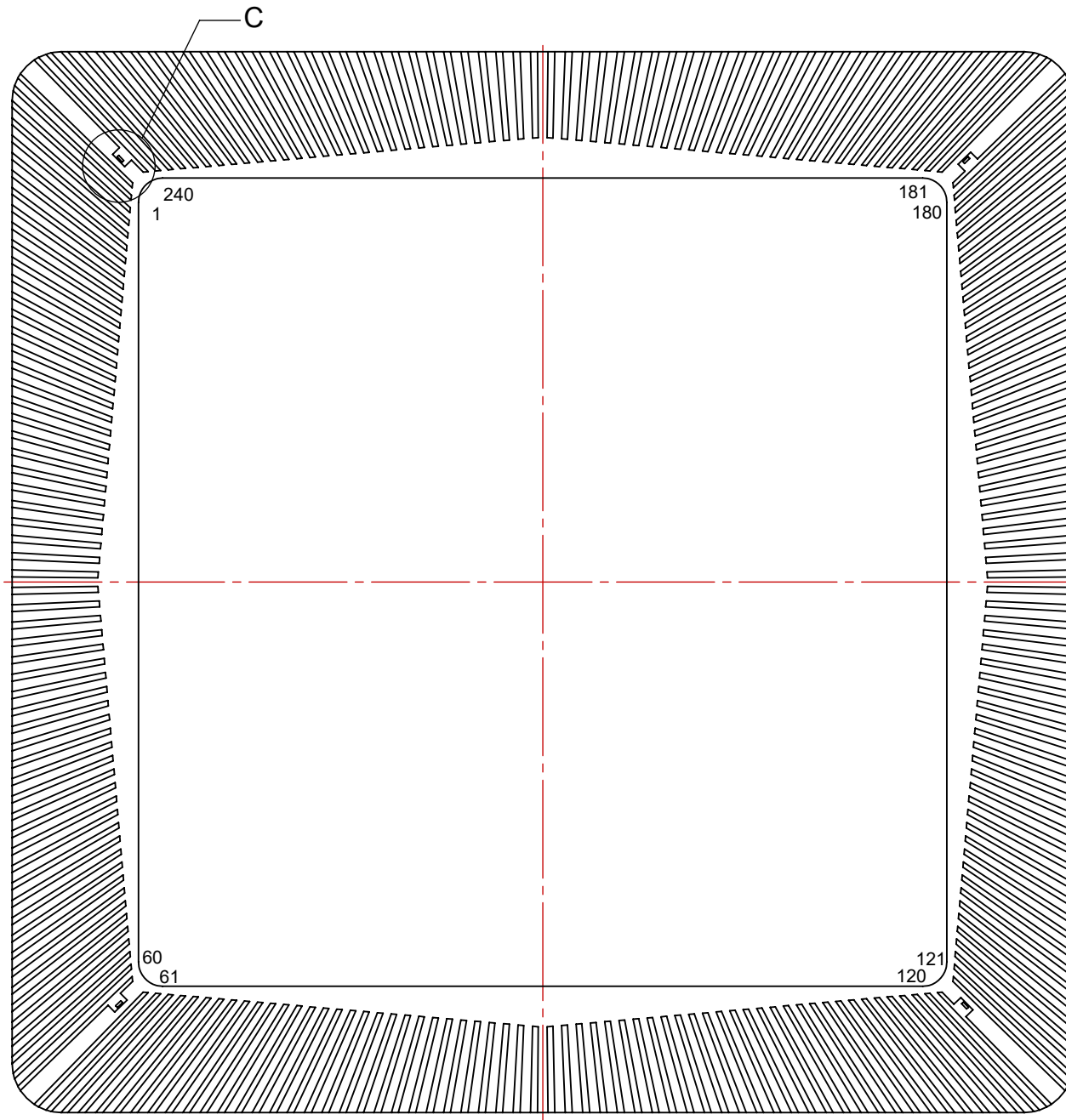

## TARGET MARK PIN No. 60, 120, 180, 140

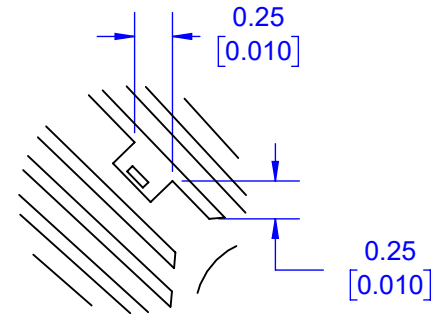

## DETAIL C SCALE 20 : 1

<b>TopLine®</b>			
TITLE CERQUAD240G19.7-N660X BARE CAVITY			
SCALE 7.5:1	SIZE A	DRAWING NO. 166287	REV A
DO NOT SCALE DRAWING			SHEET 2 OF 6

## BONDING DIAGRAM PAD ANGLE

NO.	ANGLE	No	ANGLE
1	0.415°	31	24.561°
2	1.250°	32	25.316°
3	2.079°	33	26.061°
4	2.913°	34	26.807°
5	3.741°	35	27.542°
6	4.574°	36	28.278°
7	5.400°	37	29.004°
8	6.230°	38	29.729°
9	7.053°	39	30.444°
10	7.881°	40	31.159°
11	8.701°	41	31.864°
12	9.525°	42	32.568°
13	10.341°	43	33.261°
14	11.161°	44	33.954°
15	11.972°	45	34.637°
16	12.787°	46	35.319°
17	13.593°	47	35.990°
18	14.402°	48	36.660°
19	15.203°	49	37.319°
20	16.006°	50	37.978°
21	16.800°	51	38.626°
22	17.596°	52	39.273°
23	18.834°	53	39.909°
24	19.173°	54	40.544°
25	19.952°	55	41.168°
26	20.734°	56	41.791°
27	21.505°	57	42.404°
28	22.279°	58	43.015°
29	23.042°	59	43.615°
30	23.806°	60	44.214°

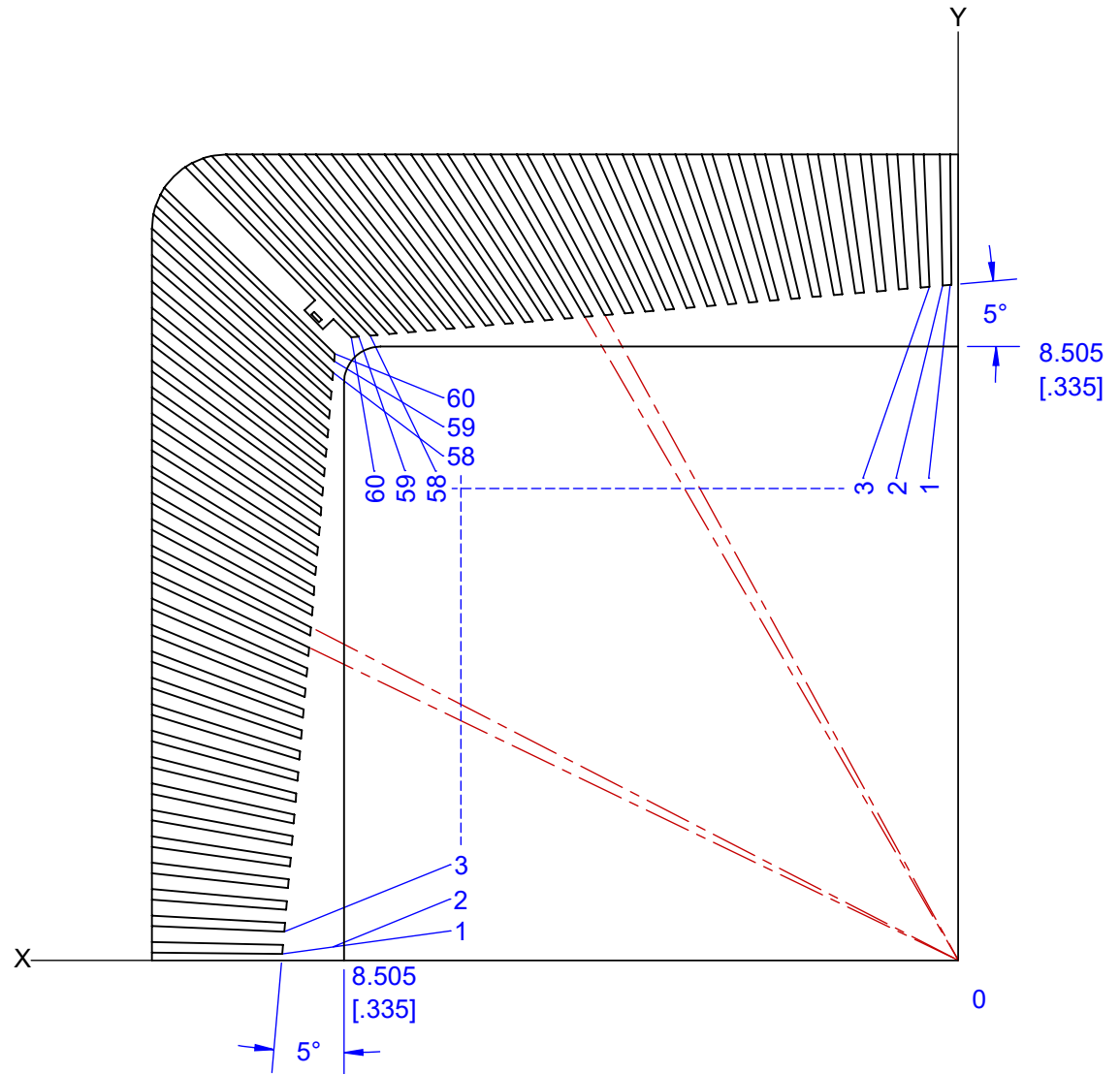

<b>TopLine<sup>®</sup></b>			
TITLE CERQUAD240G19.7-N660X BARE CAVITY			
SCALE 10:1	SIZE A	DRAWING NO. 166287	REV A
DO NOT SCALE DRAWING		SHEET 3 OF 6	

**MODELS  
OPEN PACKAGE  
WITHOUT LID**

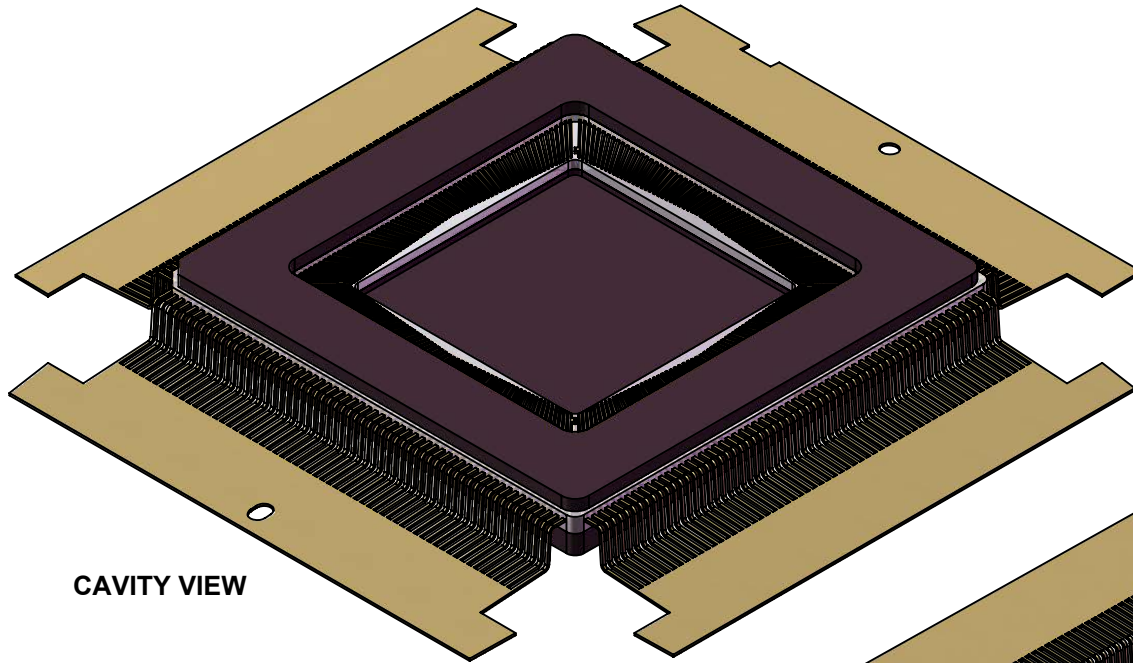

**CAVITY VIEW**

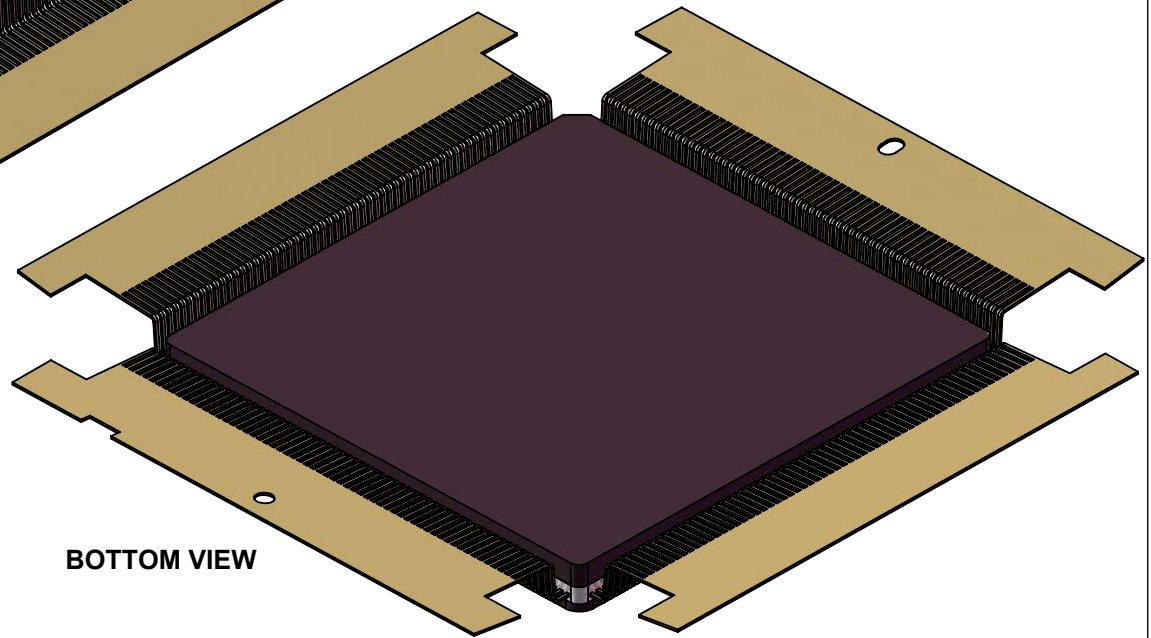

**BOTTOM VIEW**

**TopLine®**

TITLE CERQUAD240G19.7-N660X  
BARE CAVITY

SCALE 10:1	SIZE A	DRAWING NO. 166287	REV A
---------------	-----------	-----------------------	----------

DO NOT SCALE DRAWING

SHEET 4 OF 6

# CERAMIC LID EPOXY SEAL

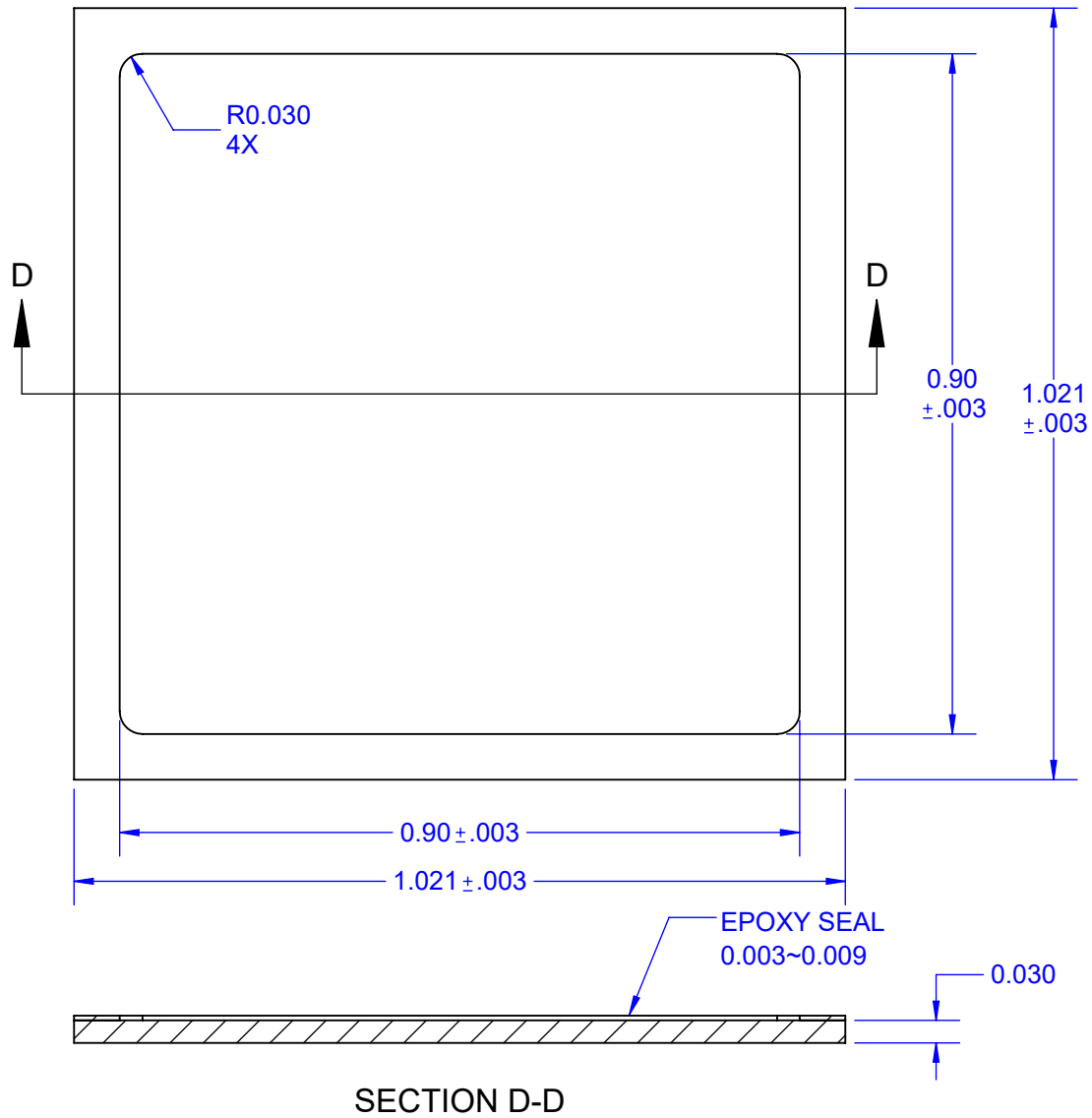

SECTION D-D

Notes: (Unless Otherwise Specified).  
1) DIMENSIONS: INCH.

<b>TopLine®</b>			
TITLE CERQUAD240G19.7-N660X BARE CAVITY			
SCALE 4:1	SIZE A	DRAWING NO. 166287	REV A
DO NOT SCALE DRAWING			SHEET 5 OF 6

LID MODELS

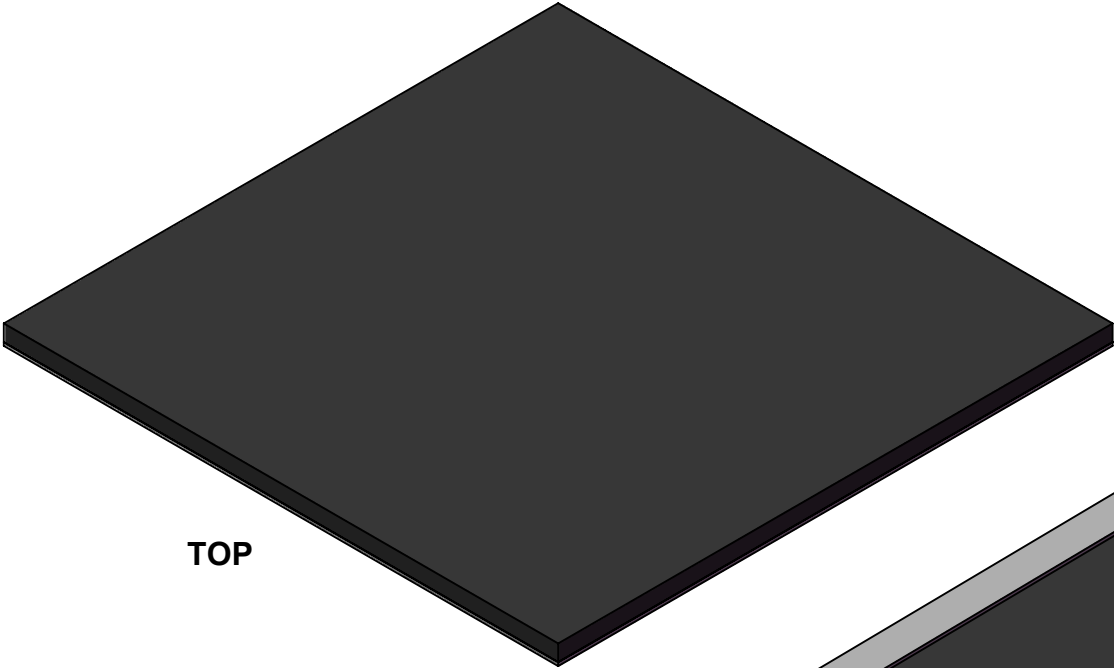

TOP

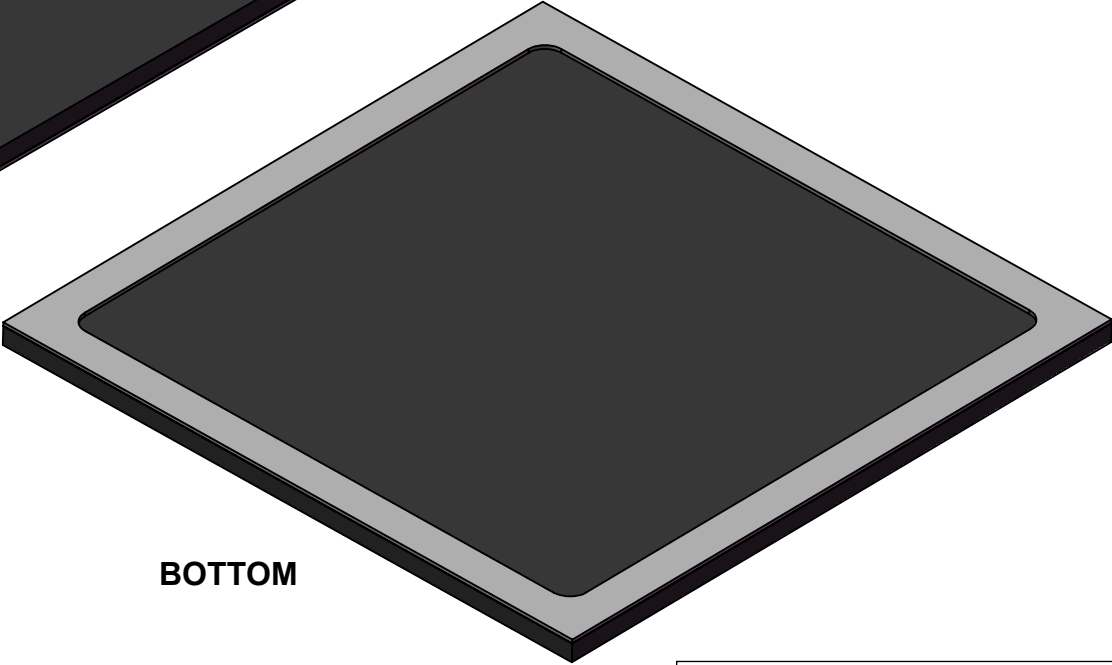

BOTTOM

<b>TopLine<sup>®</sup></b>			
TITLE		CERQUAD240G19.7-N660X BARE CAVITY	
SCALE	SIZE	DRAWING NO.	REV
4:1	A	166287	A
DO NOT SCALE DRAWING			SHEET 6 OF 6