

**TOP VIEW
(SIDE LOAD)**

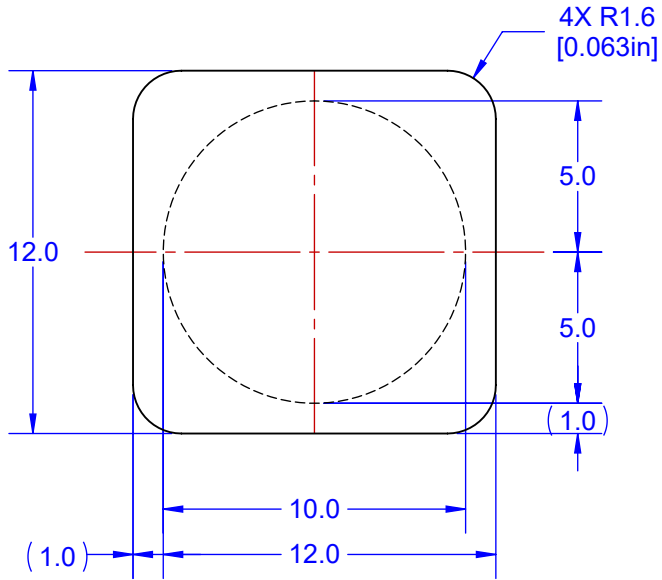

BOTTOM VIEW

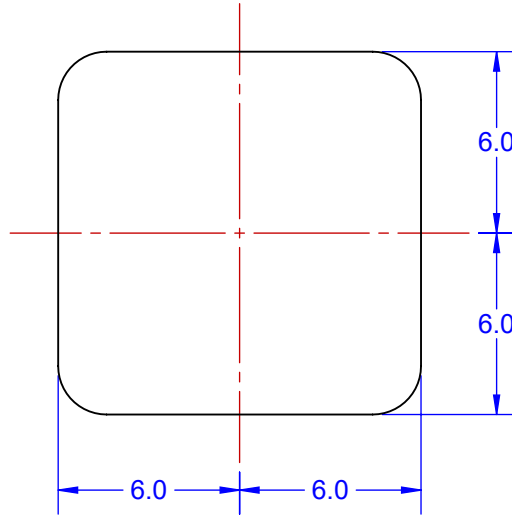

SECTION VIEW

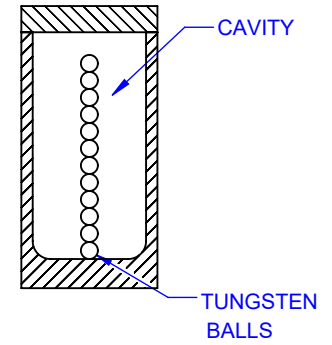

MODEL

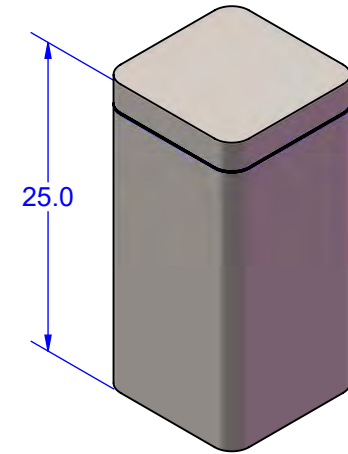

**U.S. PATENTS 10041558,
10021779, 10704639,
10704639, D842351**

DIMENSION AND WEIGHT (MASS) TABLE

| H HEIGHT ±10% | PCB MASS NOM | TUNGSTEN BALLS IN CAVITY | | | | Est. PID MASS | SCREW ADJUST | SCREW HEX HEAD |
|---------------------|--------------------|--------------------------|----------|------|------|---------------------|-----------------|----------------------|
| | | ∅ DIA | Per Ball | QTY | MASS | | | |
| 25mm | 101g | 2.0mm | 0.073g | ~130 | 10g | 30g | NA | NA |

NOTES: (Unless Otherwise Specified).
1. DIMENSIONS: MM.
2. MOUNTING: GLUE TO PCB.

| | | | | | |
|-------------|-----------|---|--------|--------------------|-------|
| APPROVALS | DATE | TopLine® | | | |
| DRAWN T. Au | 3/03/2024 | | | | |
| ENG M. Hart | 3/03/2024 | TITLE FAX10SQ12x25B PID VIBRATION DAMPER | | | |
| MFG | | SCALE 4:1 | SIZE A | DRAWING NO. 230102 | REV A |
| QA | | DO NOT SCALE DRAWING | | SHEET 1 OF 3 | |
| CUST | | | | | |
| REVISED | | | | | |

MODEL

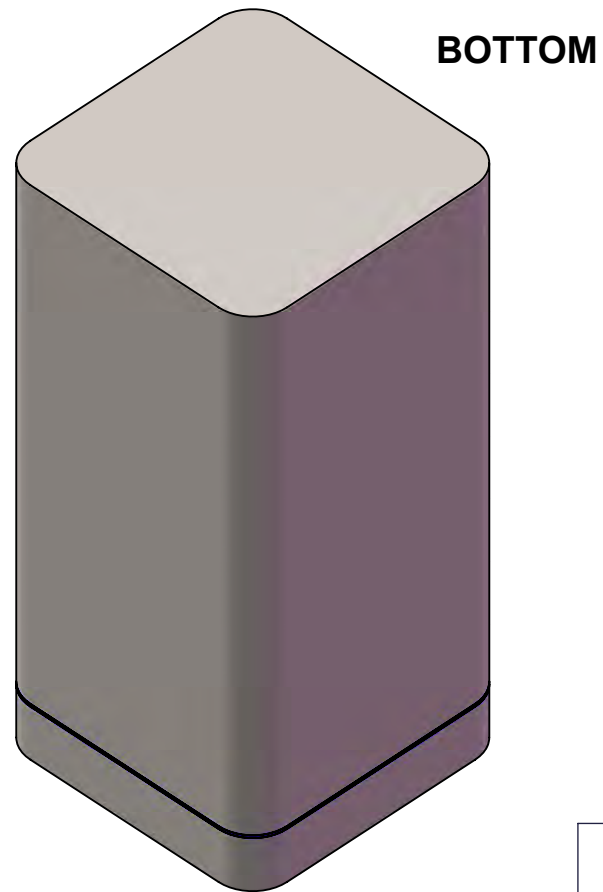
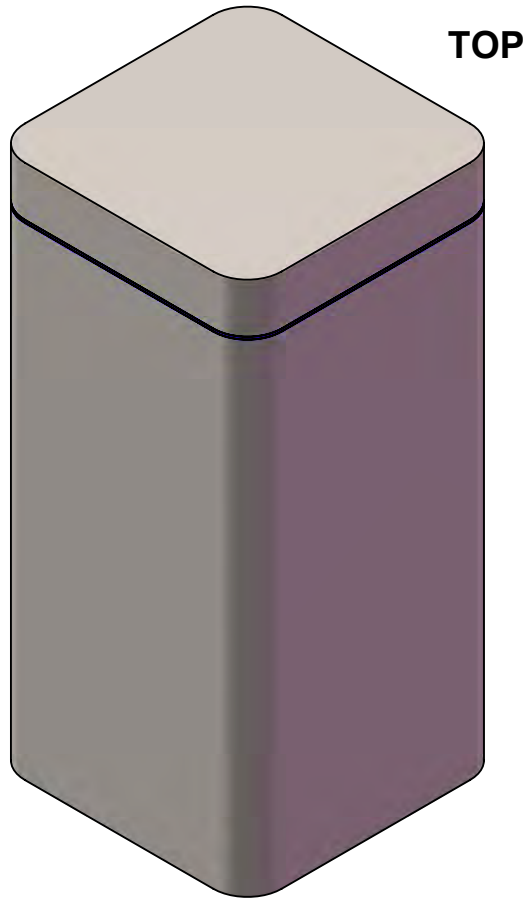

NOTES:

1. CONTACT TOPLINE FOR OTHER MOUNTING OPTIONS.

TopLine[®]

TITLE FAX10SQ12x25B
PID VIBRATION DAMPER

| | | | |
|--------------|-----------|-----------------------|----------|
| SCALE 4:1 | SIZE A | DRAWING NO. 230102 | REV A |
|--------------|-----------|-----------------------|----------|

DO NOT SCALE DRAWING

SHEET 2 OF 3

Part Number System

| <u>F</u> | <u>A</u> | <u>X</u> | <u>10</u> | <u>SQ</u> | <u>12x</u> | <u>25</u> | <u>B</u> |
|----------------------|--|--------------------|---------------------------------------|---|--|--|---|
| Series | Mounting on PCB | Variation | Tungsten Payload Grams | Exterior Shape | X/Y Size | Height | Version/Option |
| <u>Filled</u> | <u>Mounting Style</u> | <u>Code</u> | <u>Code Grams</u> | <u>Code Shape</u> | <u>Code Size</u> | <u>Code Height</u> | <u>Code Version</u> |
| F = FR4 | S = SCREW MOUNT A = ADHESIVE GLUE | X = SPECIAL | 10 = 10gm Other Mass Available | SQ Square R Rectangle C Cylindrical T Toroid Z Custom | 12x = 12mm SQ Other Sizes Available | 25 = 25mm Other Sizes Available | A = 1.5mm TUNGSTEN B = 2.0mm TUNGSTEN Other Version Available |
| <u>Empty</u> | | | | | | | |
| E = FR4 Case | | | | | | | |

Order Number

| <u>2</u> | <u>3</u> | <u>010</u> | <u>2</u> |
|--------------------------------|---|--------------------------|--|
| DESCRIPTION | Mount Style | Mass (gm) 9 = Decimal | Option Code |
| <u>Code</u> <u>Description</u> | <u>Code</u> <u>Description</u> | <u>Code</u> <u>MASS</u> | <u>Code</u> <u>Option</u> |
| 2 = Filled PID | 2 = Screw 3 = Adhesive 9 = Custom 0 = Master DWG | 010 = 010 gm | 1 = A = 1.5mm TUNGSTEN 2 = B = 2.0mm TUNGSTEN |

TopLine®

TITLE FAX10SQ12x25B
PID VIBRATION DAMPER

| | | | |
|---------------|-----------|-----------------------|----------|
| SCALE NONE | SIZE A | DRAWING NO. 230102 | REV A |
|---------------|-----------|-----------------------|----------|

DO NOT SCALE DRAWING

SHEET 3 OF 3