

TOP VIEW

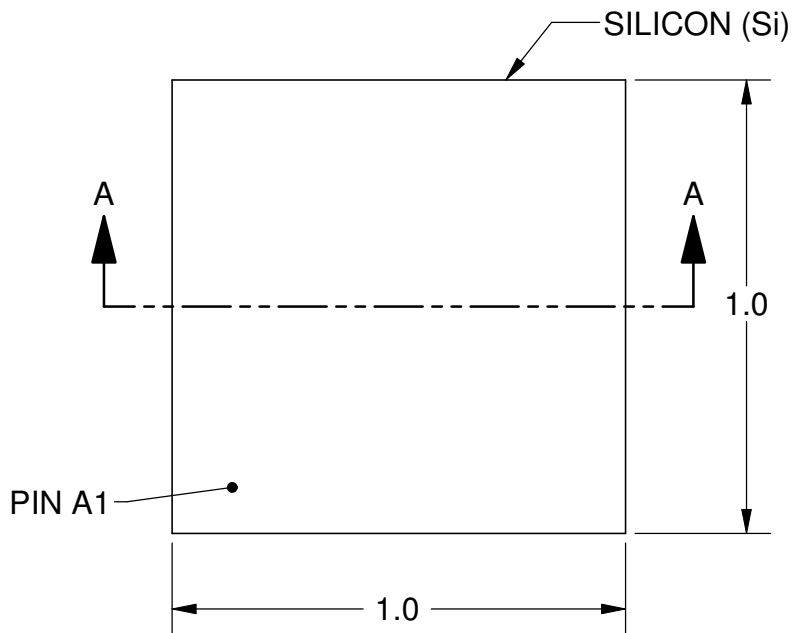

BALL VIEW

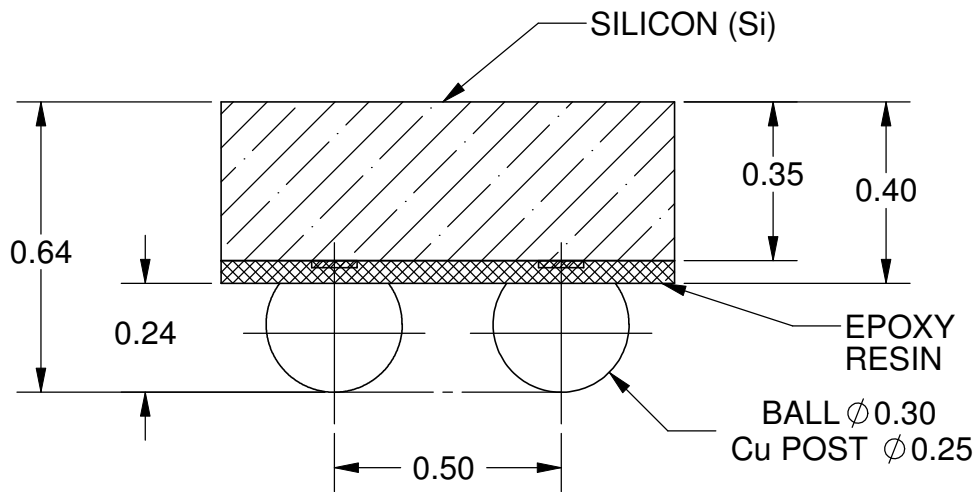
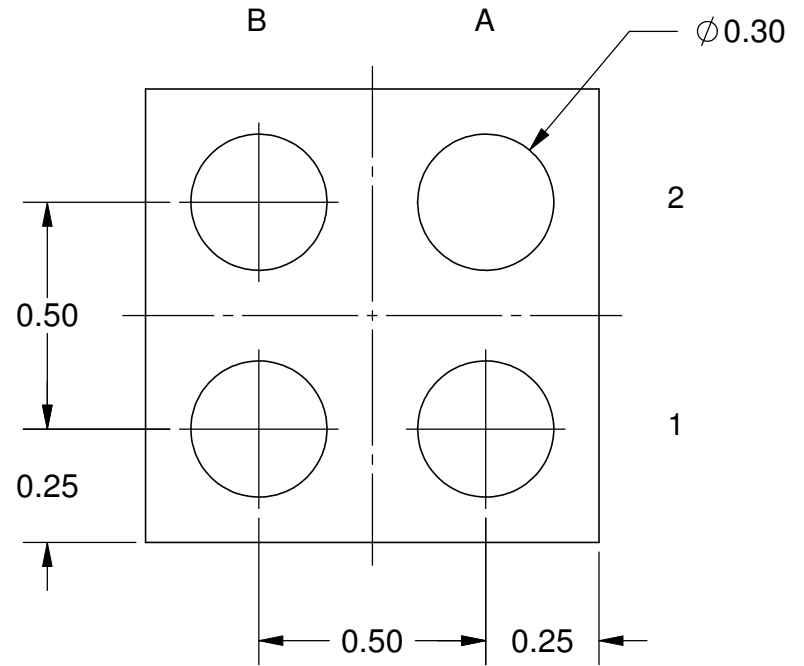

SECTION A-A

Notes: (Unless Otherwise Specified).

- 1) ALL DIMENSIONS ARE IN MM.
- 2) SOLDER BALL ALLOY:
STANDARD: SAC305 (Sn96.5/Ag3.0/Cu0.5).
SPECIAL: LF35 (Sn98.3/Ag1.2/Cu0.5).
- 3) BALL DIAMETER (BEFORE REFLOW): 0.30mm.
- 4) NON-SOLDER MASK DEFINED PAD.
- 5) PAD Cu DIAMETER: 0.25mm.
- 6) SUBSTRATE MATERIAL: Si (SILICON).
- 7) DAISY CHAIN PATTERN (SEE PAGE 2).

PART NUMBER TABLE				
PART NUMBER	BALL ALLOY	Pb-FREE	RoHS	Si DIE
WLP4T.5C-DC022D	Sn96.5/Ag3.0/Cu0.5	YES	YES	YES
WLP4T.5C1-DC022D	Sn98.3/Ag1.2/Cu0.5	YES	YES	YES

TOLERANCE UNLESS NOTED		APPROVALS		DATE	TopLine [®]			
X.X	+/- 0.3	DRAWN J. Hines		1/15/2011				
X.XX	+/- 0.03	ENG			TITLE WLP4T.5C-DC022D			
X.XXX	+/- 0.003	MFG			4-BALL P=0.5mm (TEG0510)			
ANGLES +/- 0.5°		QA			SCALE	SIZE	DRAWING NO.	REV
ALL DIMENSIONS IN		CUST			60:1	A	550222	A
<input type="checkbox"/> INCHES <input checked="" type="checkbox"/> MILLIMETERS		REVISED			DO NOT SCALE DRAWING			SHEET 1 OF 2
THIRD ANGLE PROJECTION								

DAISY CHAIN PATTERN

BALL VIEW

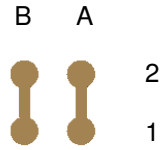

BOTTOM SIDE
(TOP X-RAY VIEW)

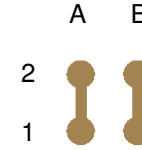

TOP VIEW

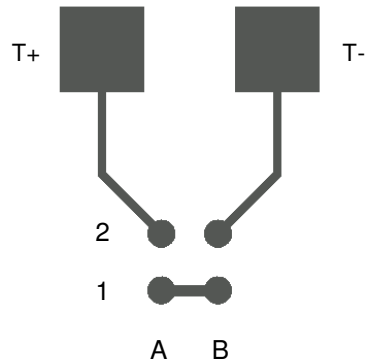

AFTER MOUNTING
TO TEST BOARD
(TOP X-RAY VIEW)

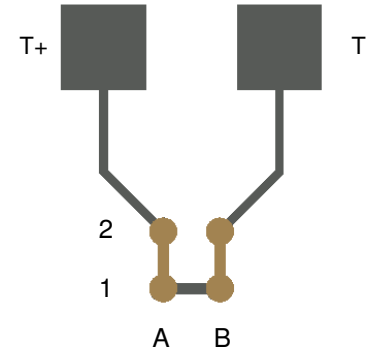

TEST VEHICLE BOARD

Notes:

- 1) PCB BOARD DIMENSIONS ARE PRESENTED ONLY AS A GUIDELINE. DESIGNERS SHOULD USE THEIR OWN EXPERIENCE WHEN DESIGNING PCB.
- 2) PCB Cu BALL PAD DIAMETER 0.25mm (9.8mil).
- 3) PCB DAISY CHAIN TRACING LINE WIDTH 0.10mm (3.9mil).

TopLine ®			
TITLE WLP4T.5C-DC022D 4-BALL P=0.5mm (TEG0510)			
SCALE 15:1	SIZE A	DRAWING NO. 550222	REV A
DO NOT SCALE DRAWING		SHEET 2 OF 2	