

TOP VIEW

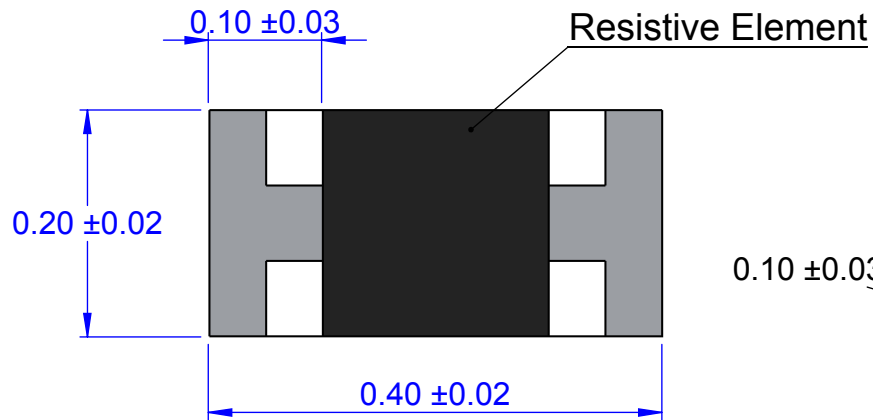

STRUCTURE

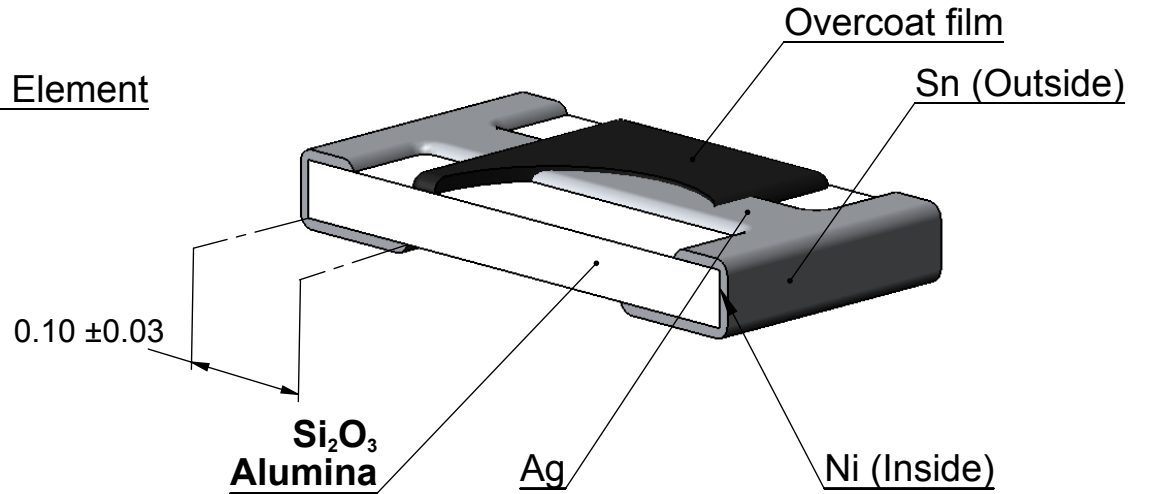

RECOMMENDED PCB PATTERN

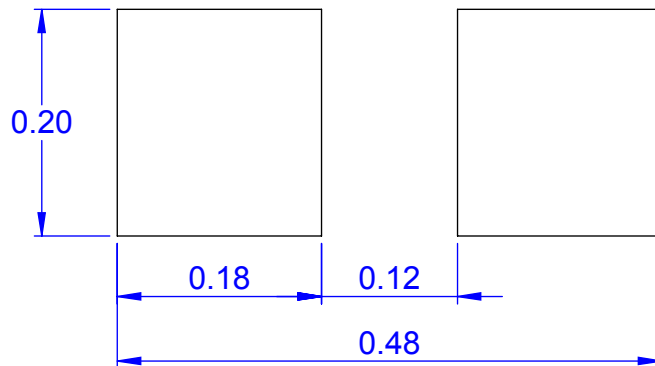

NOTES:

1. DIMENSIONS IN mm.
2. TERMINATION: Tin (Sn).
3. Pb-FREE AND HALOGEN FREE.

MODEL

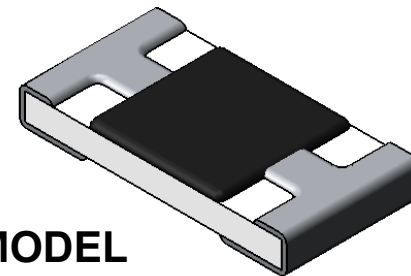

PCB DIMENSIONS ARE PRESENTED ONLY AS A GUIDELINE. DESIGNERS SHOULD USE THEIR OWN KNOWLEDGE BASE WHEN DESIGNING THE PCB.

APPROVALS	DATE	TopLine®			
DRAWN T. Au	05/17/12				
ENG M. Hart	05/17/12	TITLE SR01005			
MFG		SMT RESISTOR			
QA		SCALE	SIZE	DRAWING NO.	REV
CUST			A	120151	A
REVISED		DO NOT SCALE DRAWING			SHEET 1 OF 3

W8P2 CARRIER TAPE DIMENSION

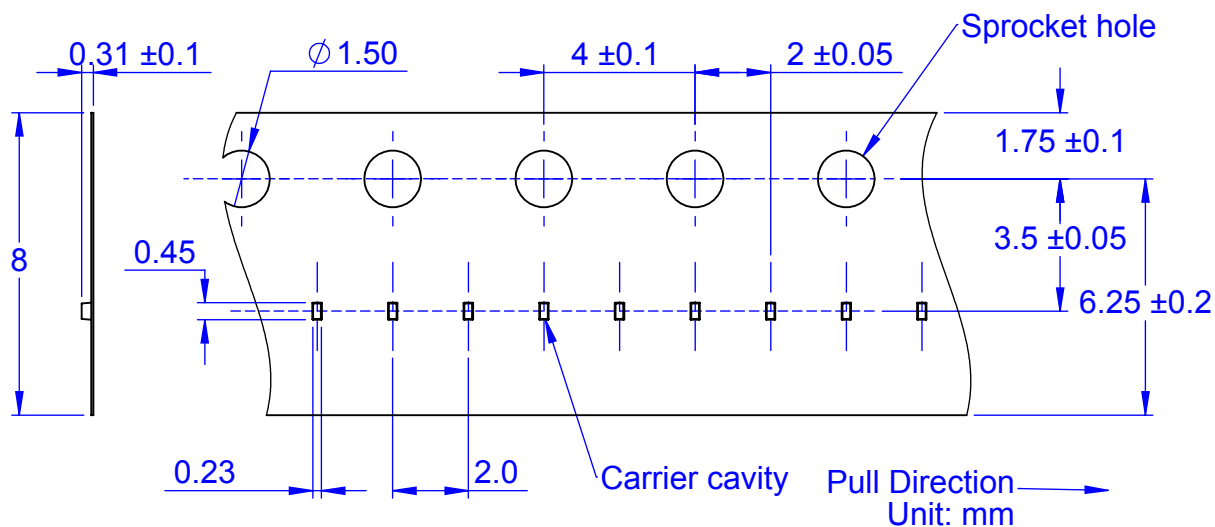

W8P2 TAPE PART NUMBER SYSTEM

SR	01005	P7A	-ZERO-	TIN
RESISTOR	SIZE CODE 0.4 x 0.2 mm	PACK CODE	50mΩ	TERMINATION Sn (TIN)

NOTE: For dummy resistor replace ZERO with blank

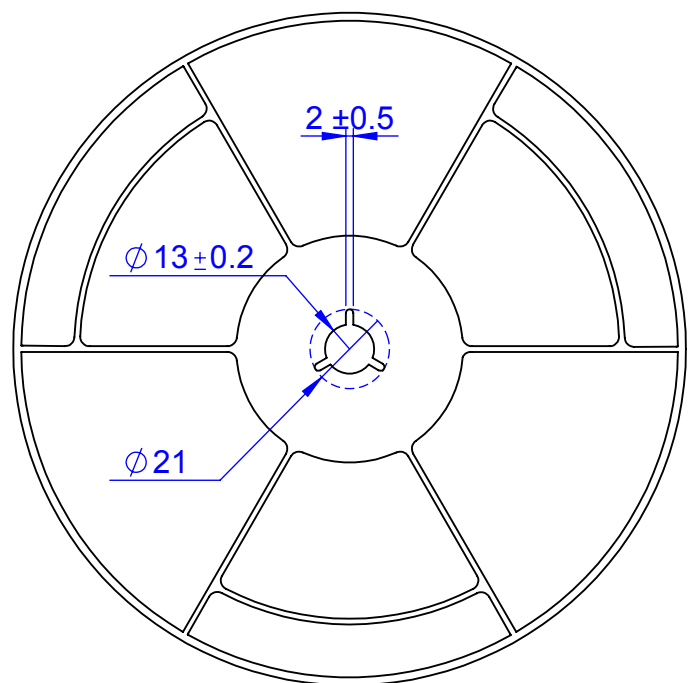

REEL DIMENSIONS

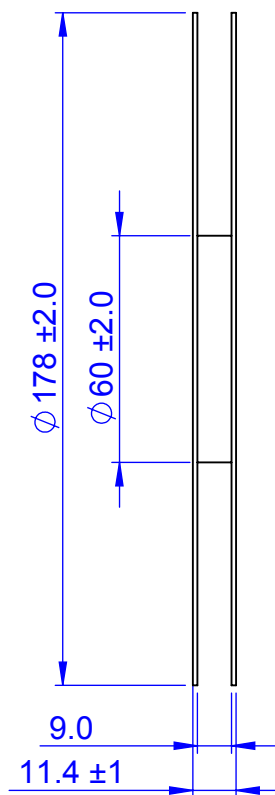

PACK CODE		
CODE	QTY	PACKAGE
P7A	20,000	REEL
P7B	10,000	REEL
P7C	5,000	REEL
P4A	1,000	REEL

APPROVALS	DATE				
DRAWN T. Au	05/17/12				
ENG M. Hart	05/17/12	TITLE SR01005 SMT RESISTOR			
MFG		SCALE	SIZE A	DRAWING NO.	REV
QA				120151	A
CUST		DO NOT SCALE DRAWING			SHEET 2 OF 3
REVISED					

W4P1 CARRIER TAPE DIMENSION

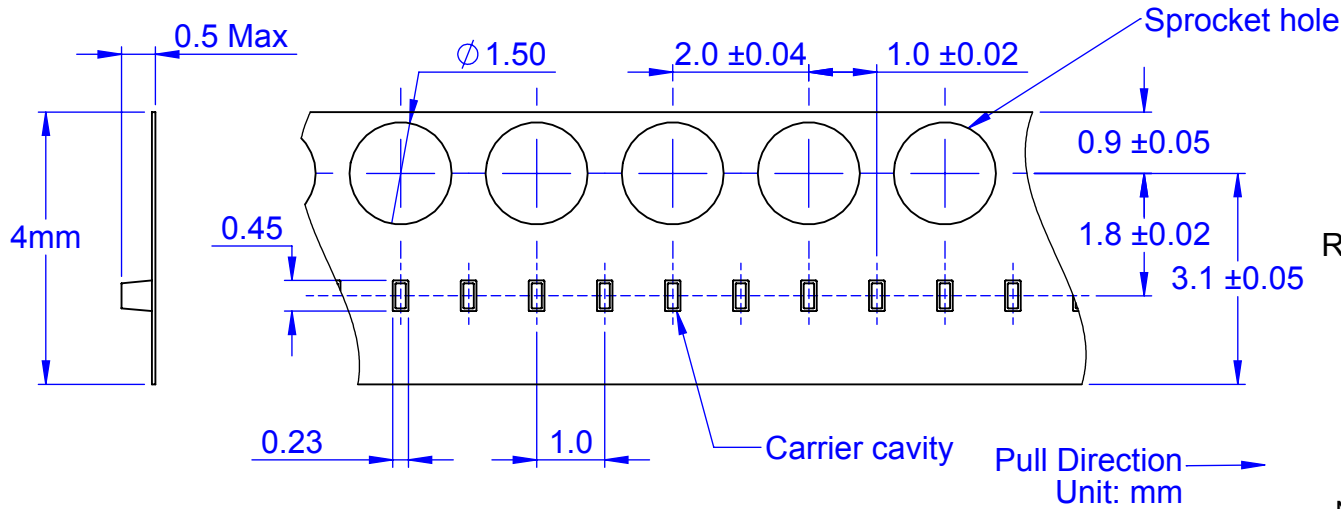

W4P1 TAPE PART NUMBER SYSTEM

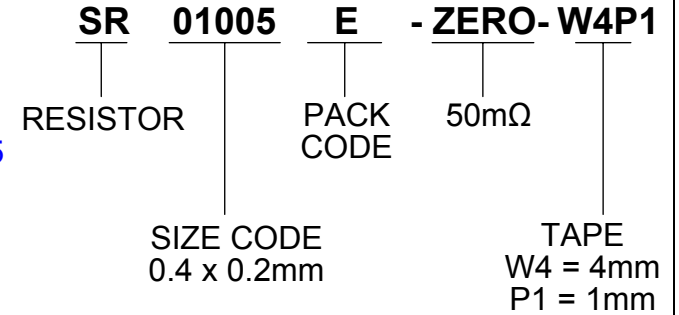

NOTE: For dummy resistor replace ZERO with blank

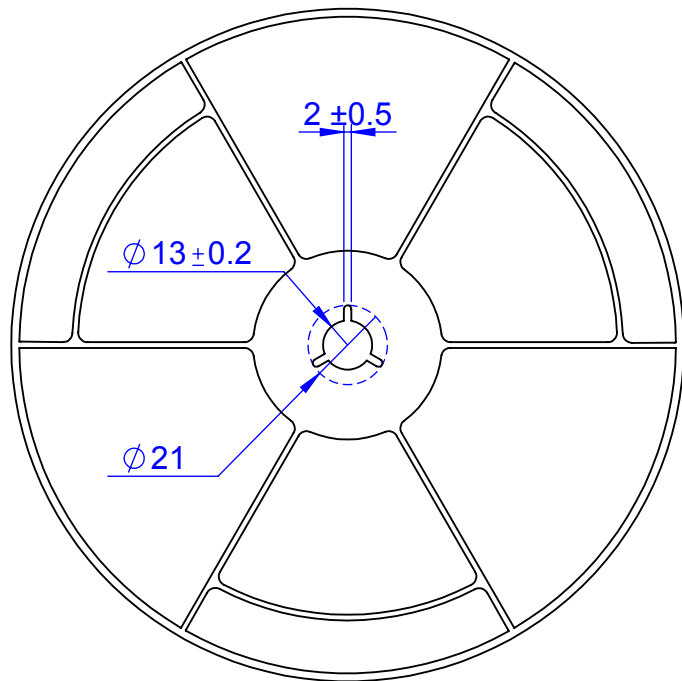

REEL DIMENSIONS

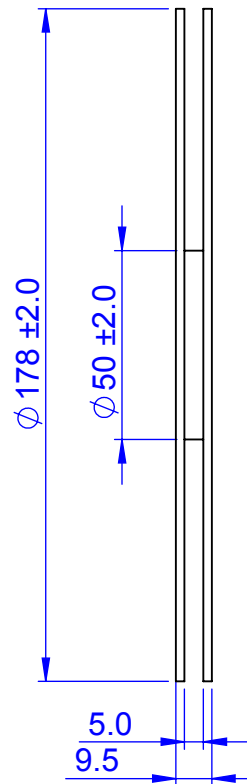

PACK CODE		
CODE	QTY	PACKAGE
E7A	40,000	REEL
E7B	20,000	REEL
E7C	10,000	REEL
E7D	5,000	REEL
E4A	1,000	REEL

APPROVALS	DATE				
DRAWN T. Au	05/17/12				
ENG M. Hart	05/17/12	TITLE SR01005			
MFG		SMT RESISTOR			
QA		SCALE	SIZE	DRAWING NO.	REV
CUST			A	120151	A
REVISED		DO NOT SCALE DRAWING			SHEET 3 OF 3