

**SIDE**

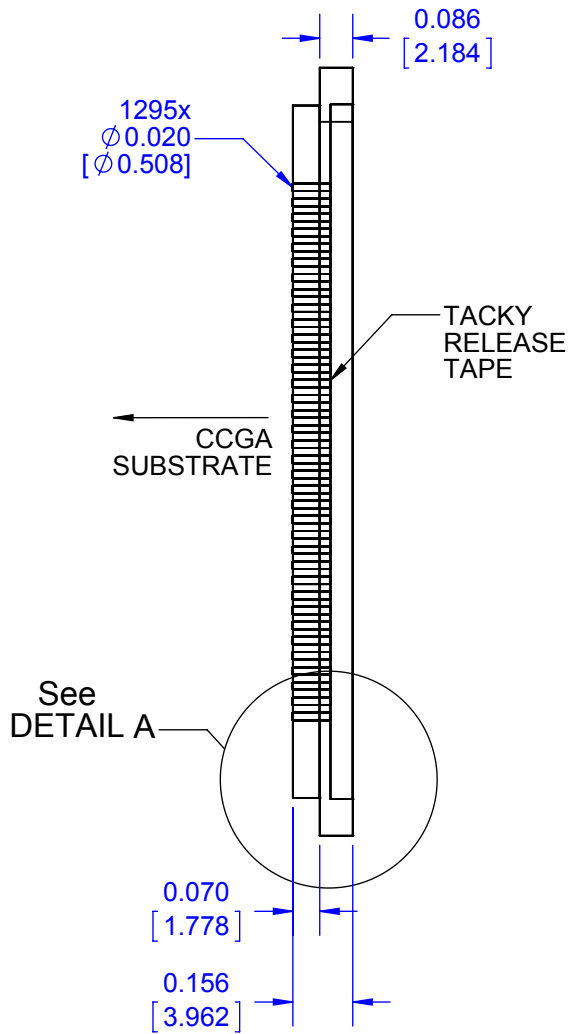

**TOP VIEW**

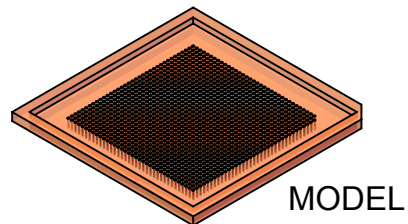
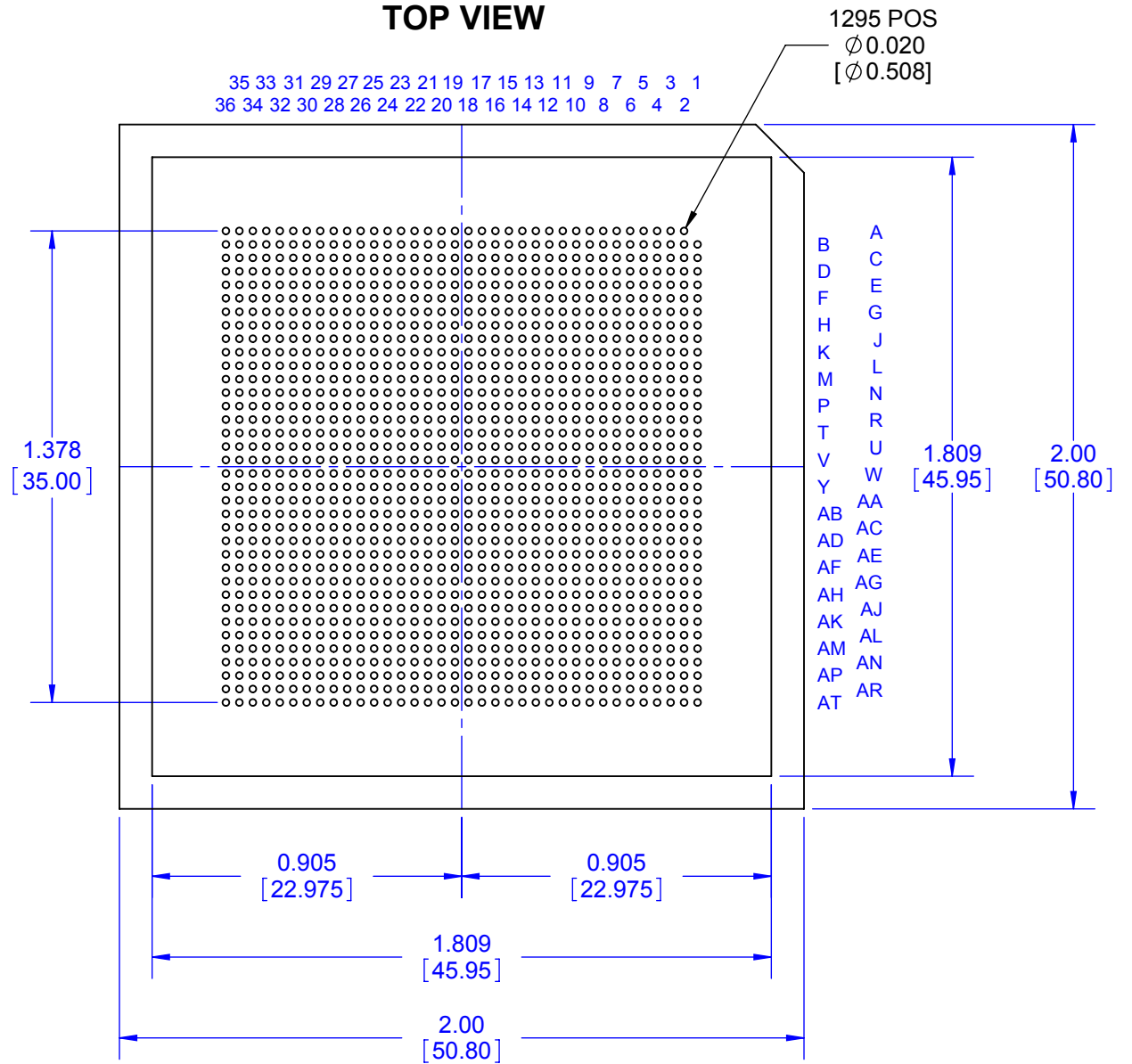

NOTES:  
1. DIMENSIONS INCHES [MM].  
2. SHOWN WITH MAXIMUM ARRAY.

<b>TopLine®</b>			
TITLE PP1295A Pin-PACK™ Ø0.38mm CCGA COLUMN CARRIER			
SCALE 2:1	SIZE A	DRAWING NO. 001361	REV A
DO NOT SCALE DRAWING			SHEET 1 OF 8

# DETAIL A

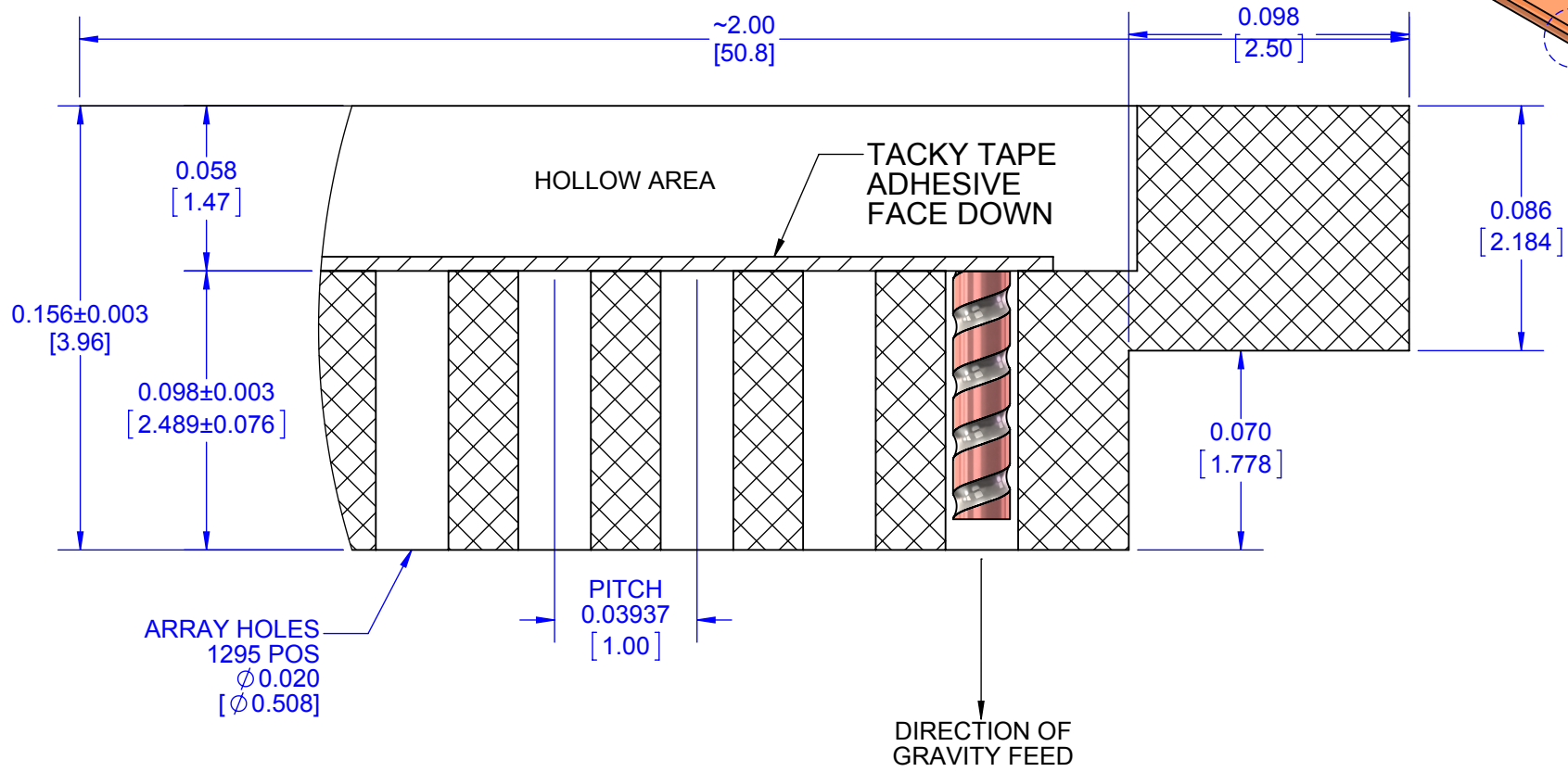
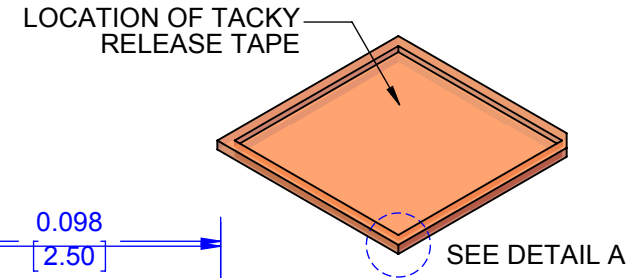

## EXAMPLES OF COLUMNS

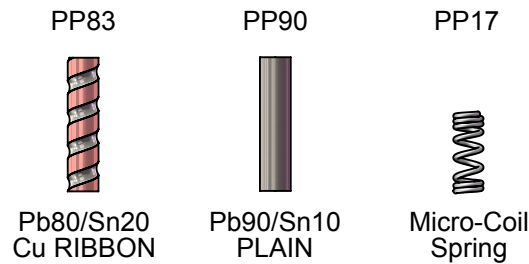

NOTES:  
1. DIMENSIONS INCHES [MM].

<b>TopLine®</b>			
TITLE PP1295A Pin-PACK™ Ø0.38mm CCGA COLUMN CARRIER			
SCALE 16:1	SIZE A	DRAWING NO. 001361	REV A
DO NOT SCALE DRAWING			SHEET 2 OF 8

**PART NUMBER TABLE**

PIN-PACK™	Pins	Pitch	Matrix	COLUMN BEFORE TRIM				Empty DWG	Filled DWG
				Alloy	Construction	Ø Dia	Length		
PP83C1295E15x87A PP90U1295E15x87A PP17P1295E16x40A	1295	1.00mm	36x36	Pb80 Pb90 MCS	Cu Ribbon Plain Micro Coil	0.38mm	2.2mm 2.2mm 1.0mm	001361	831361 901361 171361

36 35 34 33 32 31 30 29 28 27 26 25 24 23 22 21 20 19 18 17 16 15 14 13 12 11 10 9 8 7 6 5 4 3 2 1

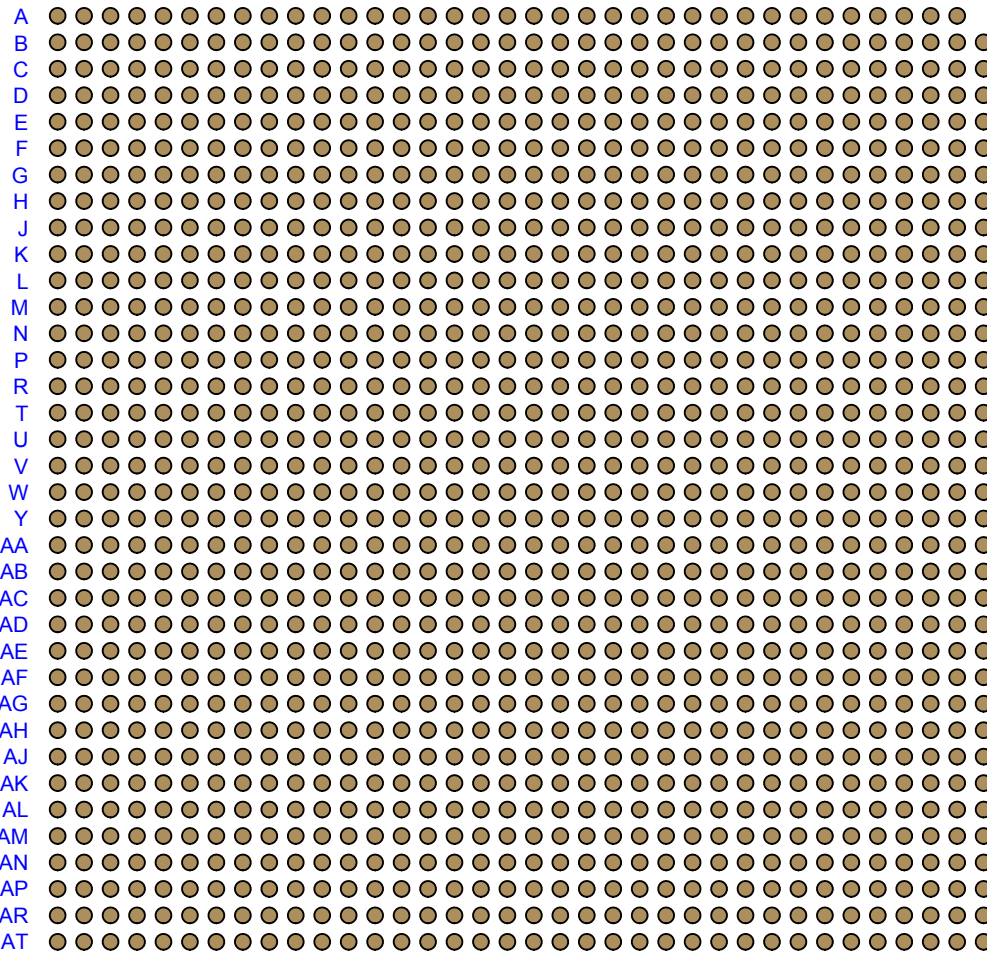

**EXAMPLES OF COLUMNS**

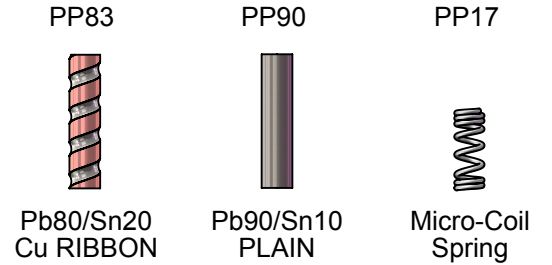

<b>TopLine®</b>			
TITLE PP1295A Pin-PACK™ Ø0.38mm CCGA COLUMN CARRIER			
SCALE NONE	SIZE A	DRAWING NO. 001361	REV A
DO NOT SCALE DRAWING			SHEET 3 OF 8

# PIN-PACK™ PART NUMBERING SYSTEM

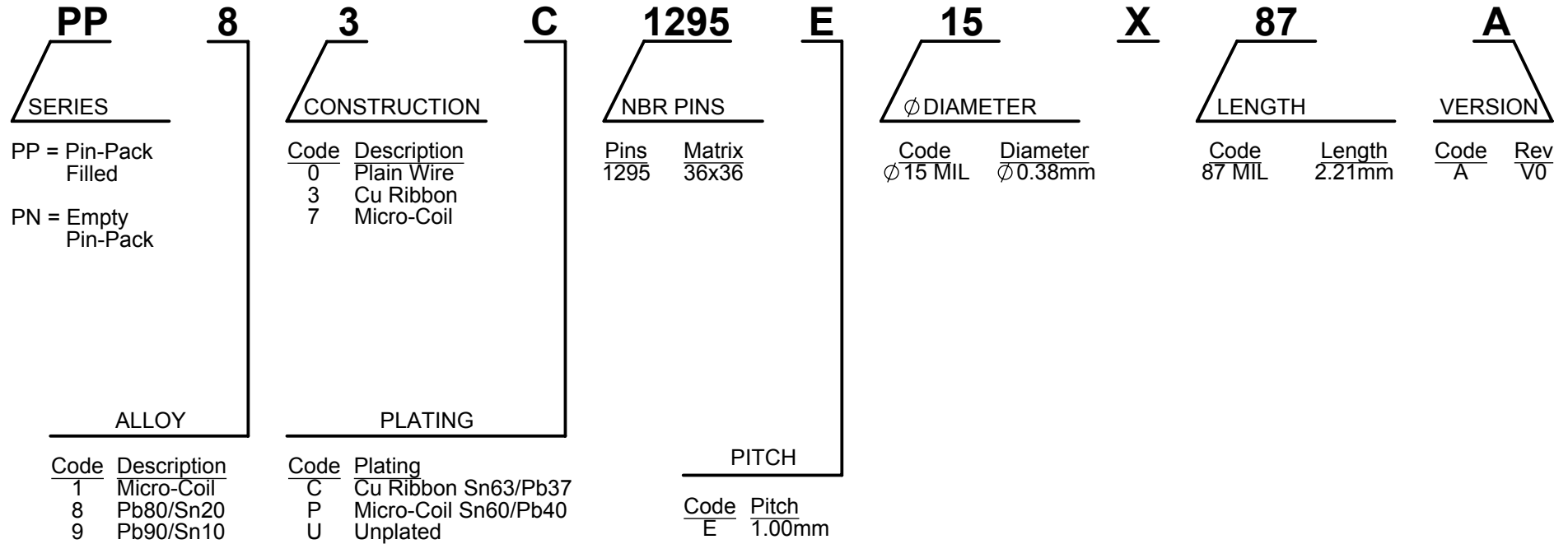

## EXAMPLES OF COLUMNS

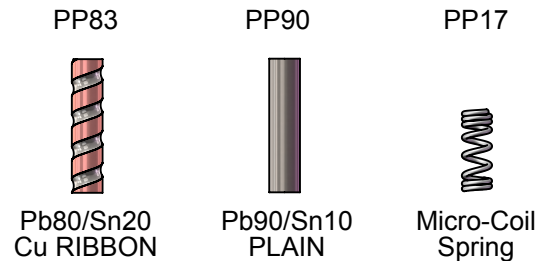

NOTE 1: PP83 and PP93 REQUIRES TRIMMING TO FINISHED LENGTH.  
 NOTE 2: COLUMN 2.21mm TO BE TRIMMED TO 2.11mm AFTER ATTACHMENT.

<b>TopLine®</b>			
TITLE PP1295A Pin-PACK™ Ø0.38mm CCGA COLUMN CARRIER			
SCALE 10:1	SIZE A	DRAWING NO. 001361	REV A
DO NOT SCALE DRAWING			SHEET 4 OF 8

# PIN-PACK™ DRAWING NUMBERING SYSTEM

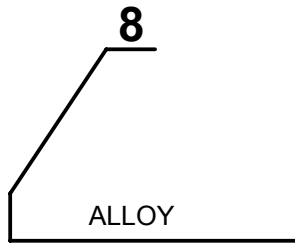

Code	Description
00	Empty
1	Micro-Coil
8	Pb80/Sn20
9	Pb90/Sn10

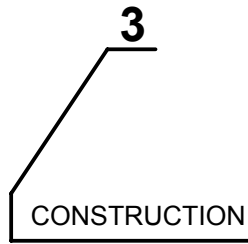

Code	Description
0	Plain Wire
3	Cu Ribbon
7	Micro-Coil

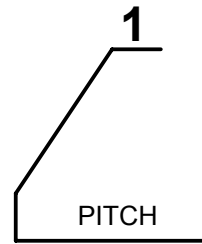

Code	Pitch
1	1.0mm

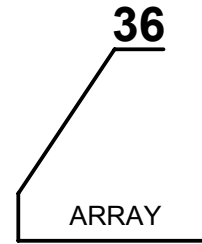

Code	Matrix
36	36x36

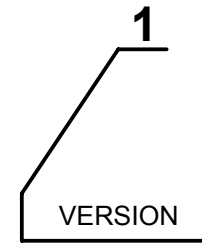

Code	Rev
1	1295 PINS 0.38mm

## EXAMPLES OF COLUMNS

PP83



Pb80/Sn20  
Cu RIBBON

PP90



Pb90/Sn10  
PLAIN

PP17



Micro-Coil  
Spring

**TopLine®**

TITLE PP1295A Pin-PACK™ Ø0.38mm  
CCGA COLUMN CARRIER

SCALE	SIZE	DRAWING NO.	REV
10:1	A	001361	A

DO NOT SCALE DRAWING

SHEET 5 OF 8

# PIN-PACK™ OUTLINE

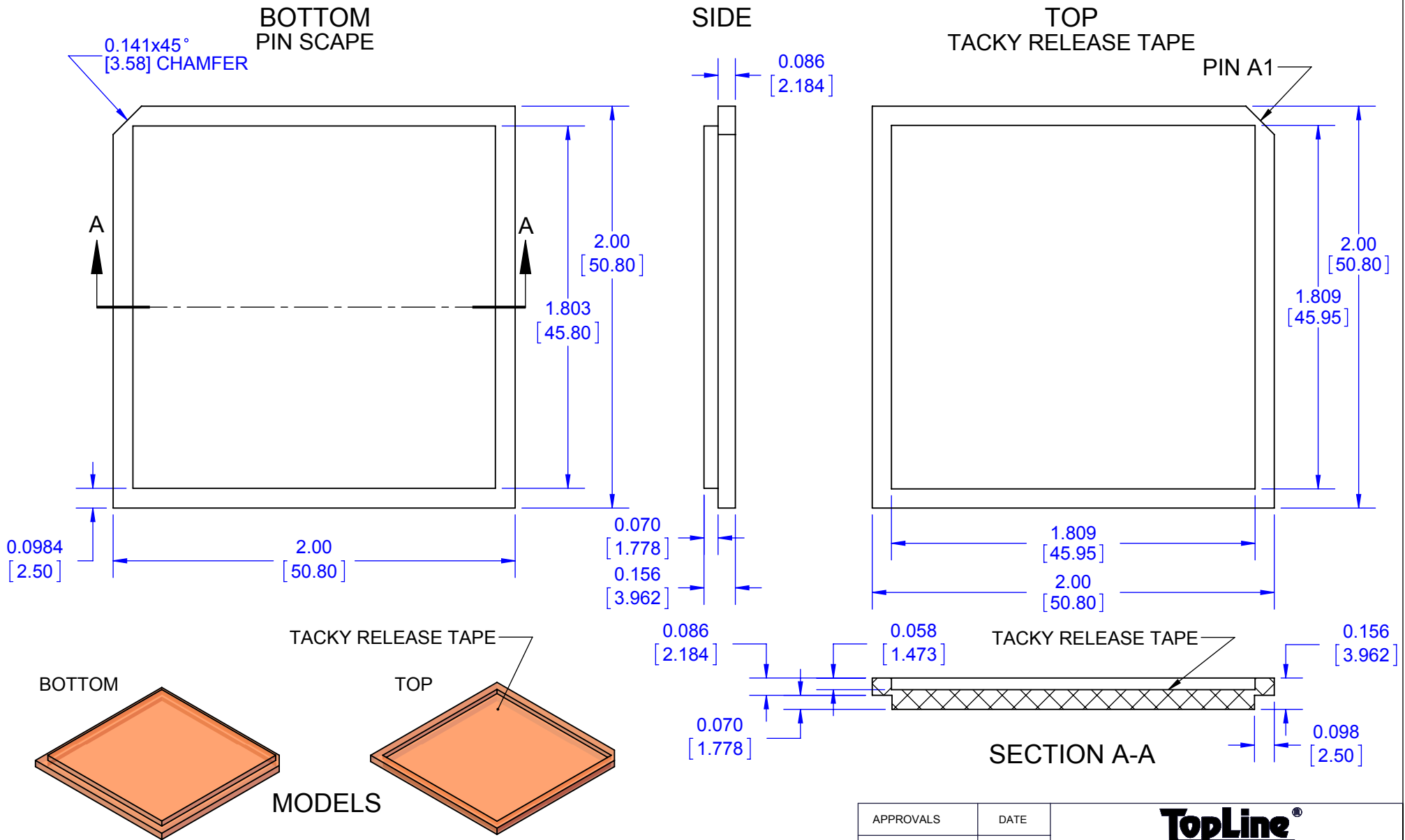

- NOTES:**
1. DIMENSIONS INCHES [MM].
  2. SHOWN WITHOUT HOLES FOR CLARITY.
  3. PIN-PACK™ IS TRADEMARK OF TOPLINE.
  4. PIN-PACK™ PATENT PENDING.

APPROVALS	DATE	<b>TopLine®</b>			
DRAWN T.Au	05/05/15				
ENG M. Hart	05/05/15	TITLE PP1295A Pin-PACK™ Ø0.38mm CCGA COLUMN CARRIER			
MFG		SCALE	SIZE	DRAWING NO.	REV
QA		3:2	A	001361	A
CUST		DO NOT SCALE DRAWING			SHEET 6 OF 8
REVISED					

# TACKY RELEASE TAPE TOP VIEW

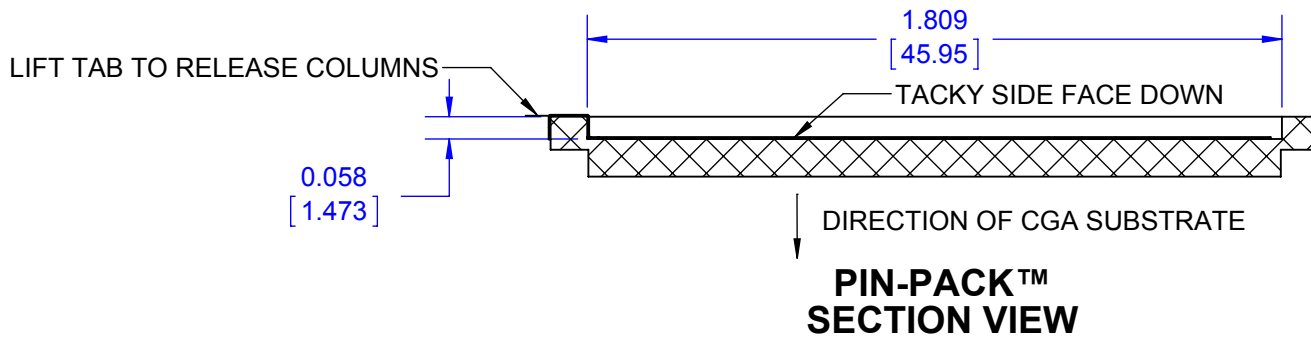
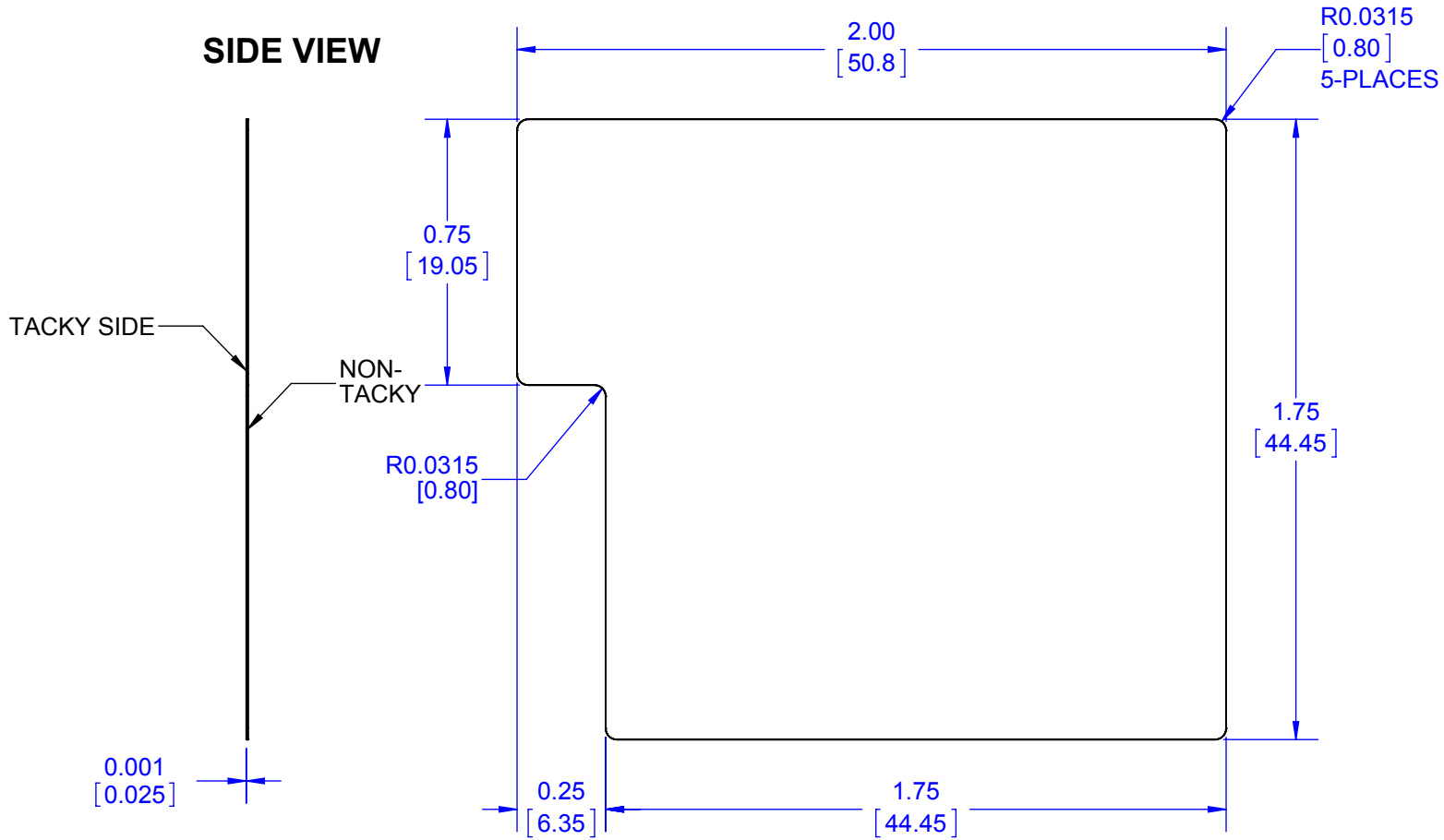

**TopLine®**

TITLE PP1295A Pin-PACK™ Ø0.38mm  
CCGA COLUMN CARRIER

SCALE	SIZE	DRAWING NO.	REV
2:1	A	001361	B

DO NOT SCALE DRAWING

SHEET 7 OF 8

# TACKY RELEASE TAPE MODEL

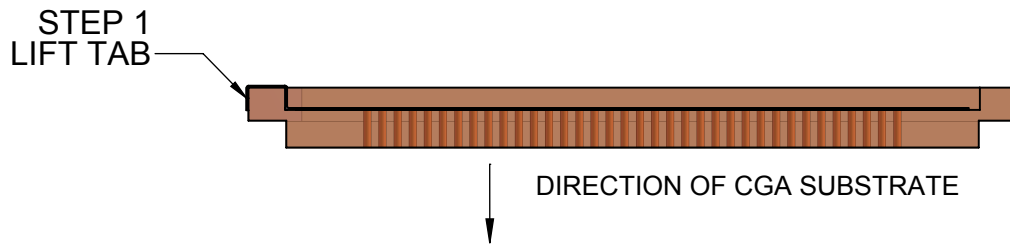
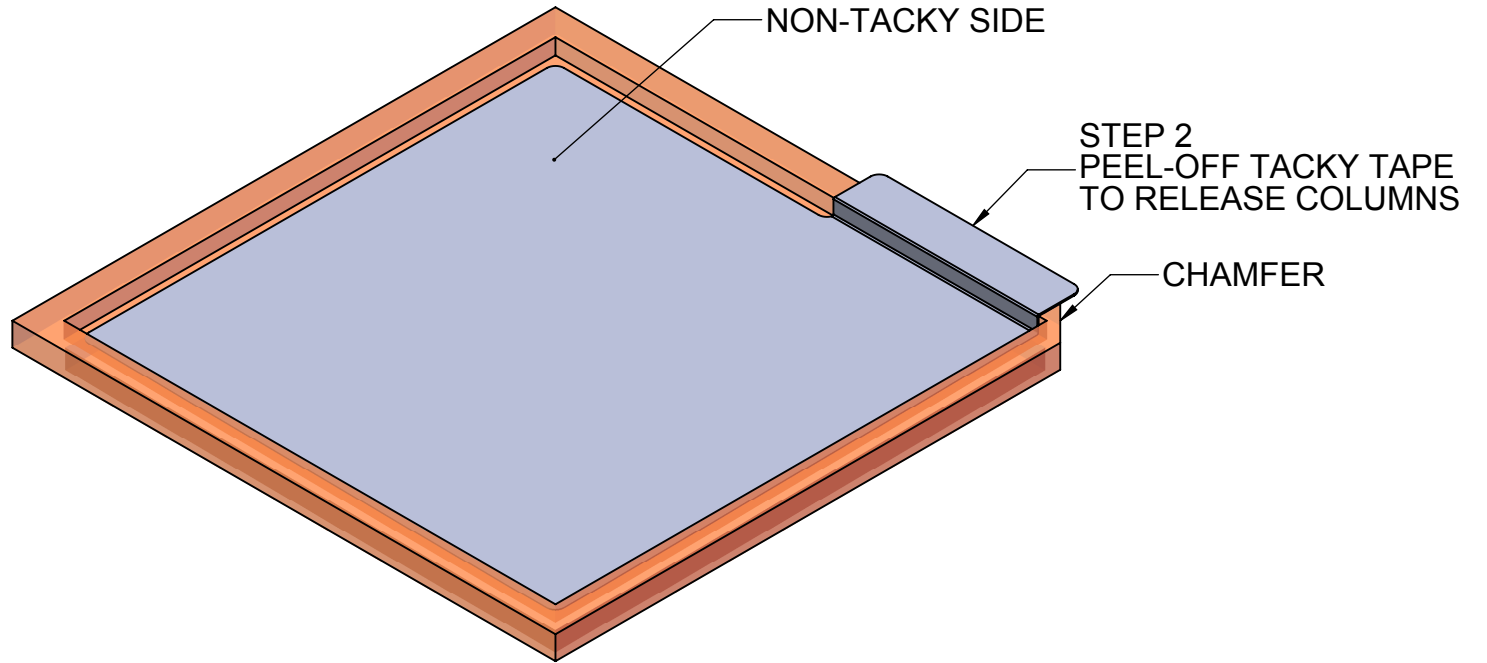

**TopLine**<sup>®</sup>

TITLE PP1295A Pin-PACK™  $\varnothing$ 0.38mm  
CCGA COLUMN CARRIER

SCALE	SIZE	DRAWING NO.	REV
1.5:1	A	001361	B

DO NOT SCALE DRAWING

SHEET 8 OF 8