

SIDE

TOP VIEW

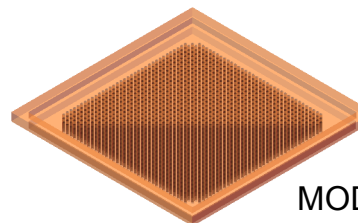
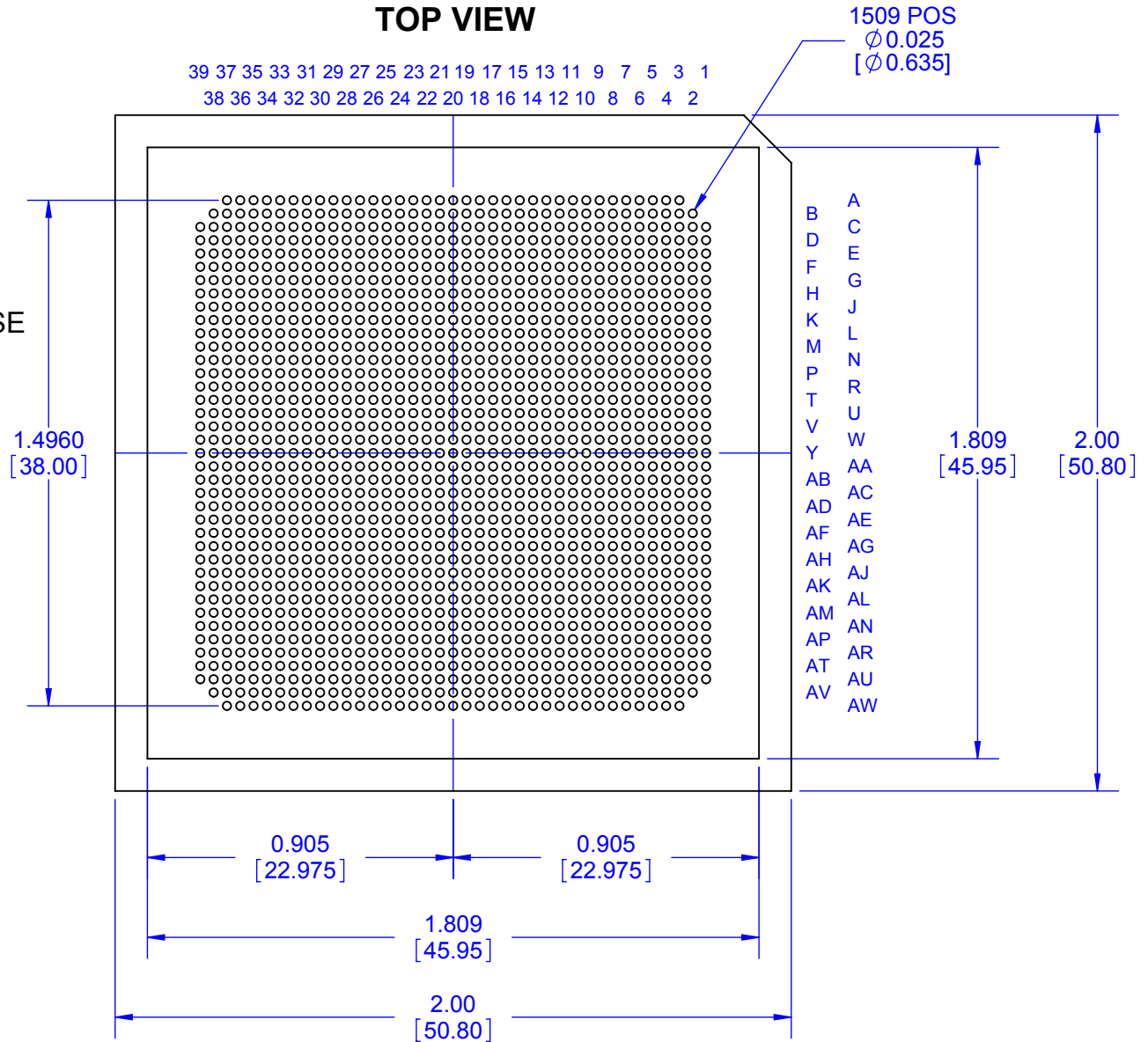
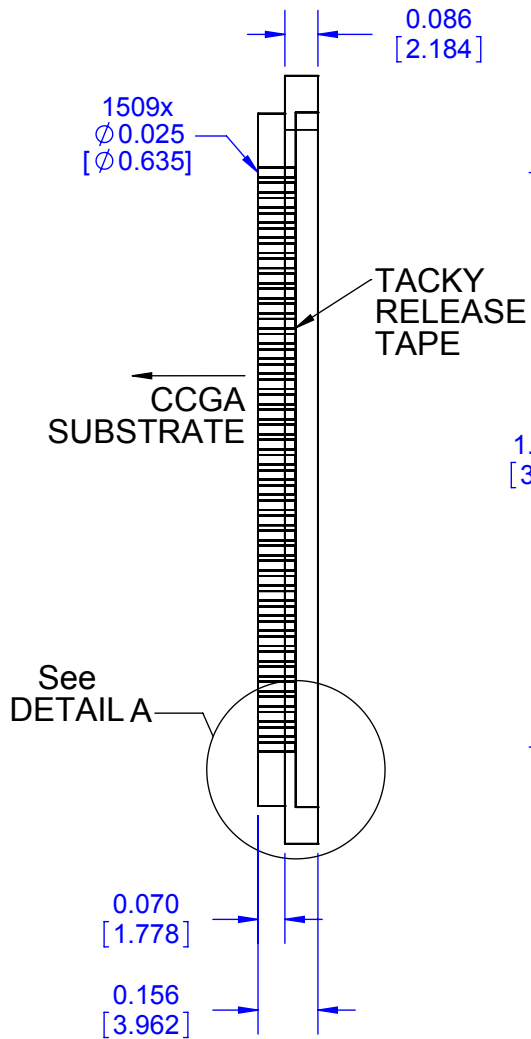

MODEL

NOTES:
 1. DIMENSIONS INCHES [MM].
 2. SHOWN WITH MAXIMUM ARRAY.

| | | | |
|-----------------------------------------------|-----------|-----------------------|--------------|
| TopLine® | | | |
| TITLE PP1509 PIN-PACK™ CCGA COLUMN CARRIER | | | |
| SCALE 2:1 | SIZE A | DRAWING NO. 001394 | REV A |
| DO NOT SCALE DRAWING | | | SHEET 1 OF 8 |

DETAIL A

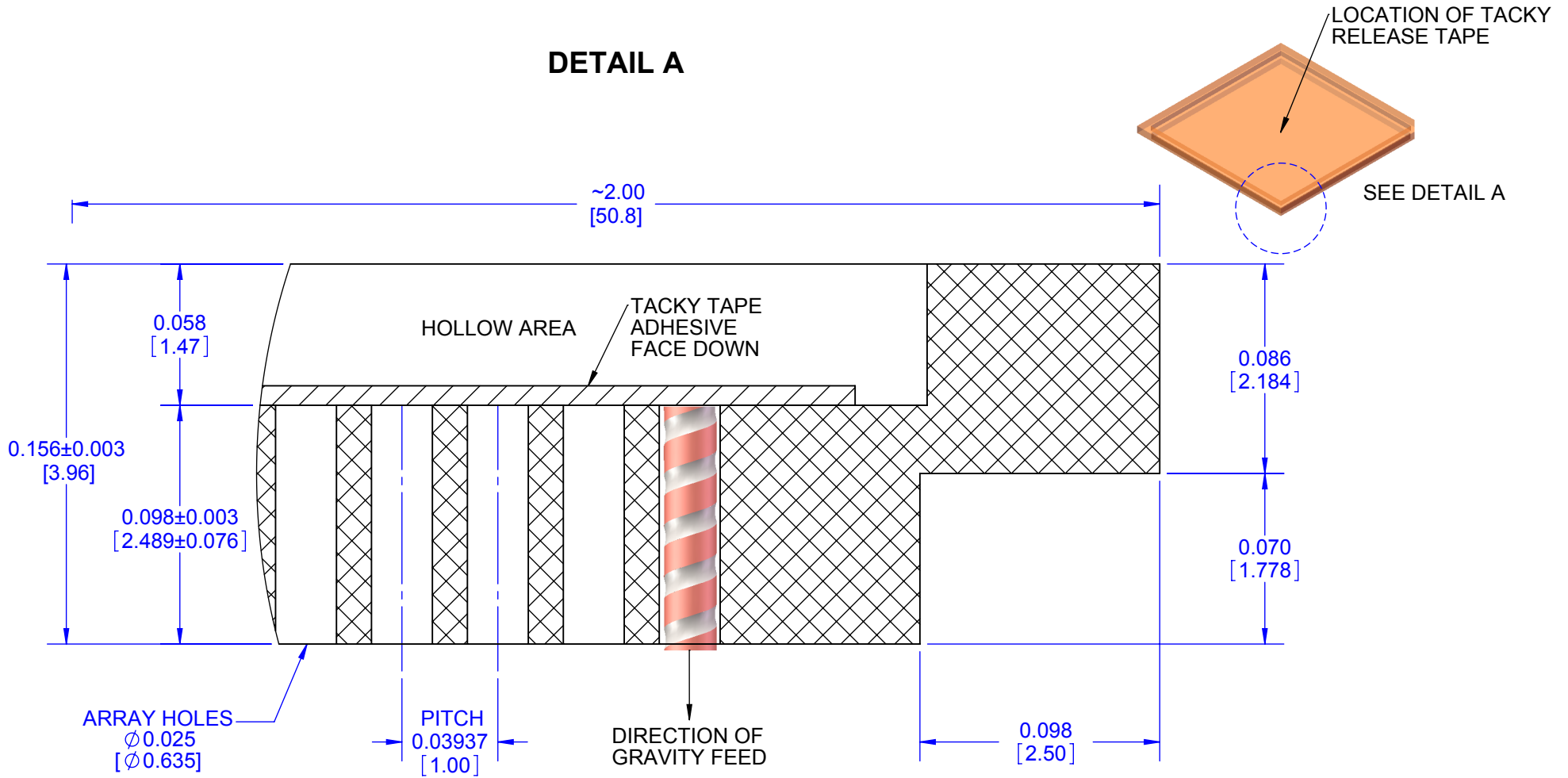

EXAMPLES OF COLUMNS

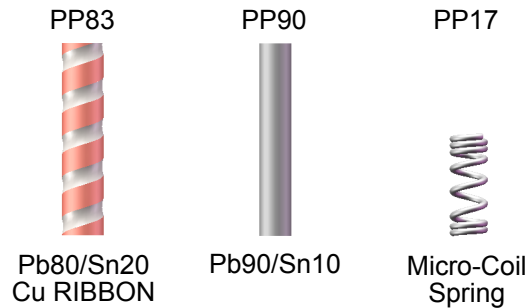

NOTES:
1. DIMENSIONS INCHES [MM].

| | | | |
|-----------------------------------------------|-----------|-----------------------|--------------|
| TopLine® | | | |
| TITLE PP1509 PIN-PACK™ CCGA COLUMN CARRIER | | | |
| SCALE 16:1 | SIZE A | DRAWING NO. 001394 | REV A |
| DO NOT SCALE DRAWING | | | SHEET 2 OF 8 |

PART NUMBER TABLE

| PIN-PACK™ | Pins | Pitch | Matrix | COLUMN | | | | Empty DWG | Filled DWG |
|------------------------------------------------------------|------|-------|--------|---------------------|----------------------------------|--------|----------------------------|-----------|----------------------------|
| | | | | Alloy | Construction | ∅ Dia | Length | | |
| PP83C1509E20x100A PP90U1509E20x100A PP17P1509E20x50A | 1509 | 1.0mm | 39x39 | Pb80 Pb90 MCS | Cu Ribbon Plain Micro Coil | 0.51mm | 2.54mm 2.54mm 1.27mm | 001394 | 831394 901394 171394 |

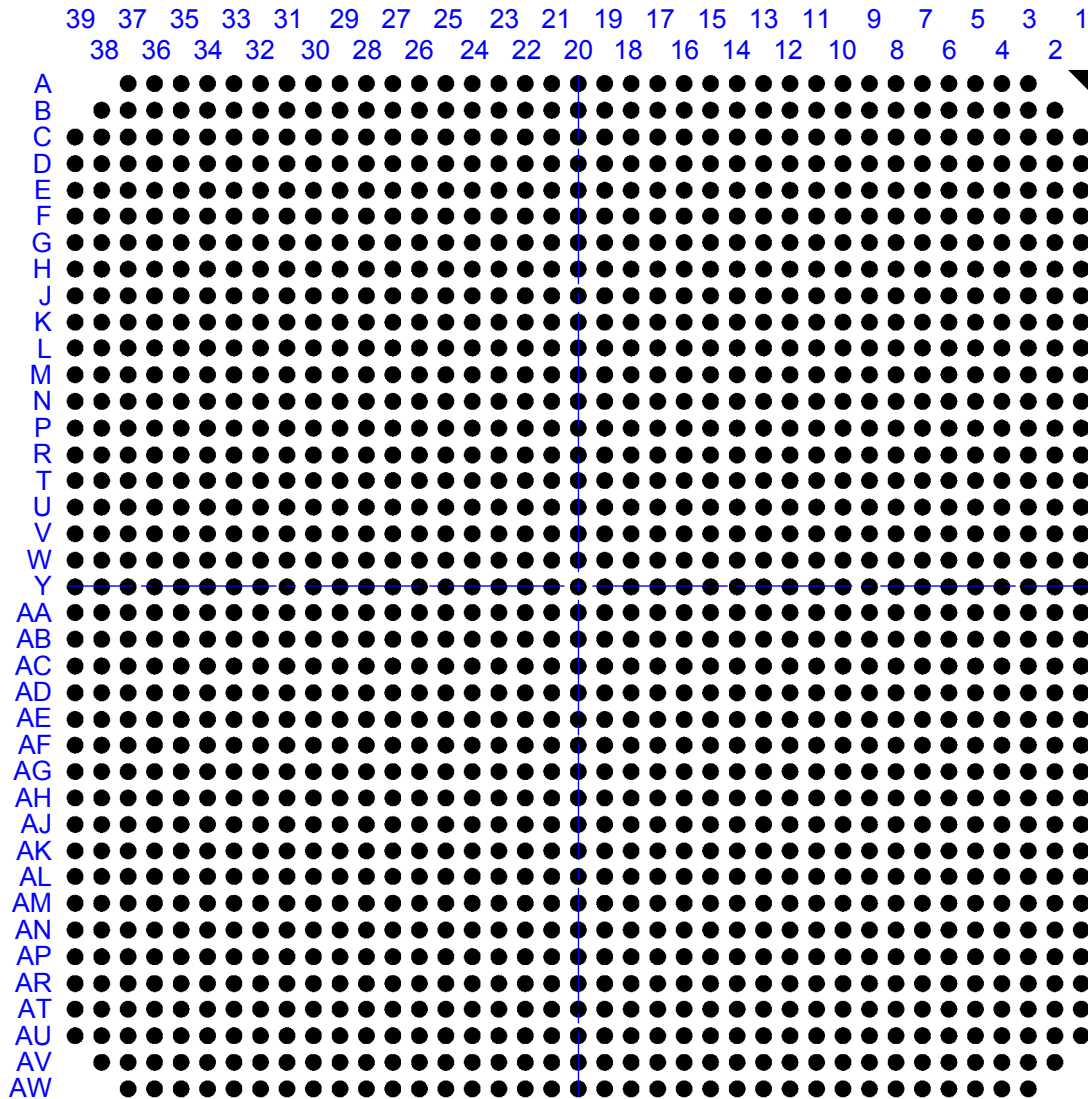

EXAMPLES OF COLUMNS

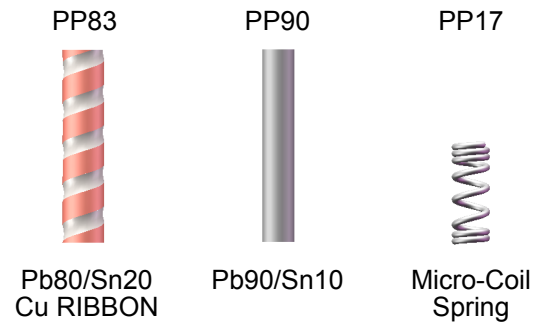

| | | | |
|--------------------------------------------------|-----------|-----------------------|--------------|
| TITLE PP1509 PIN-PACK™ CCGA COLUMN CARRIER | | | |
| SCALE NONE | SIZE A | DRAWING NO. 001394 | REV A |
| DO NOT SCALE DRAWING | | | SHEET 3 OF 8 |

PIN-PACK™ PART NUMBERING SYSTEM

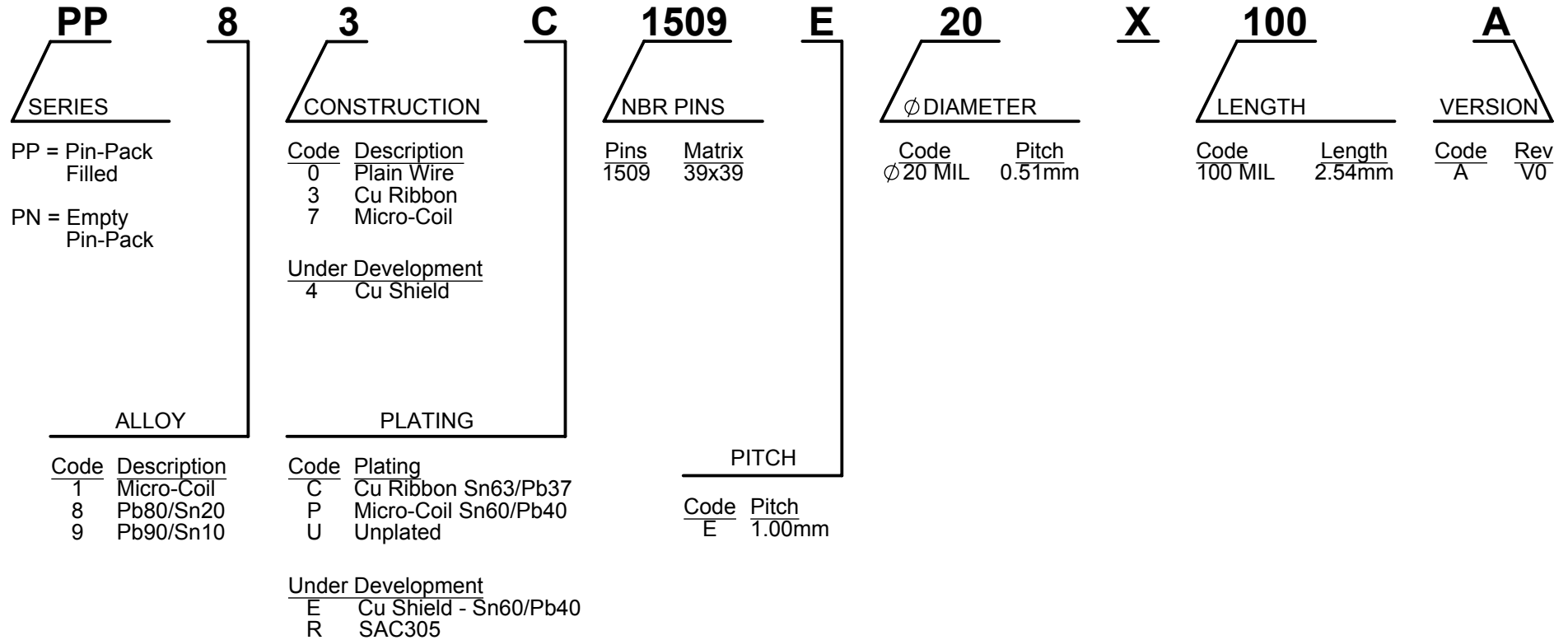

EXAMPLES OF COLUMNS

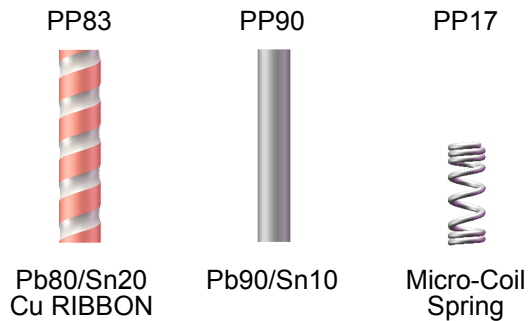

NOTE 1: PP83, PP90 and PP93 REQUIRES TRIMMING TO FINISHED LENGTH.
NOTE 2: COLUMN 2.54mm TO BE TRIMMED TO 2.21mm AFTER ATTACHMENT.

| | | | |
|----------------------------------------------------|-----------|-----------------------|--------------|
| TopLine® | | | |
| TITLE PP1509 PIN-PACK™ CCGA COLUMN CARRIER | | | |
| SCALE 10:1 | SIZE A | DRAWING NO. 001394 | REV A |
| DO NOT SCALE DRAWING | | | SHEET 4 OF 8 |

PIN-PACK™ DRAWING NUMBERING SYSTEM

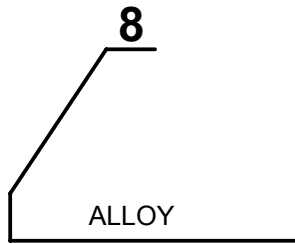

| Code | Description |
|------|-------------|
| 00 | Empty |
| 1 | Micro-Coil |
| 8 | Pb80/Sn20 |
| 9 | Pb90/Sn10 |

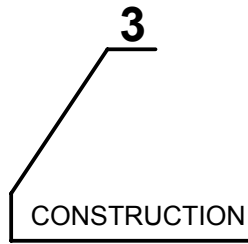

| Code | Description |
|------|-------------|
| 0 | Plain Wire |
| 3 | Cu Ribbon |
| 7 | Micro-Coil |

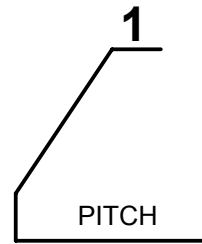

| Code | Pitch |
|------|-------|
| 1 | 1.0mm |

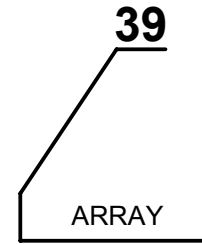

| Code | Matrix |
|------|--------|
| 39 | 39x39 |

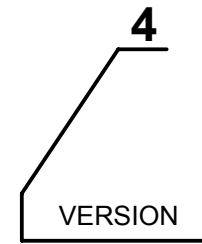

| Code | Rev |
|------|-----------|
| 4 | 1509 PINS |

Under Development

| | |
|---|----------------|
| 4 | Cu + Sn60/Pb40 |
| 5 | Cu + SAC |
| 6 | Sn60/Pb40 |

EXAMPLES OF COLUMNS

PP83



Pb80/Sn20
Cu RIBBON

PP90



Pb90/Sn10

PP17



Micro-Coil
Spring

TopLine®

TITLE PP1509 PIN-PACK™
CCGA COLUMN CARRIER

| SCALE | SIZE | DRAWING NO. | REV |
|-------|------|-------------|-----|
| 10:1 | A | 001394 | A |

DO NOT SCALE DRAWING

SHEET 5 OF 8

PIN-PACK™ OUTLINE

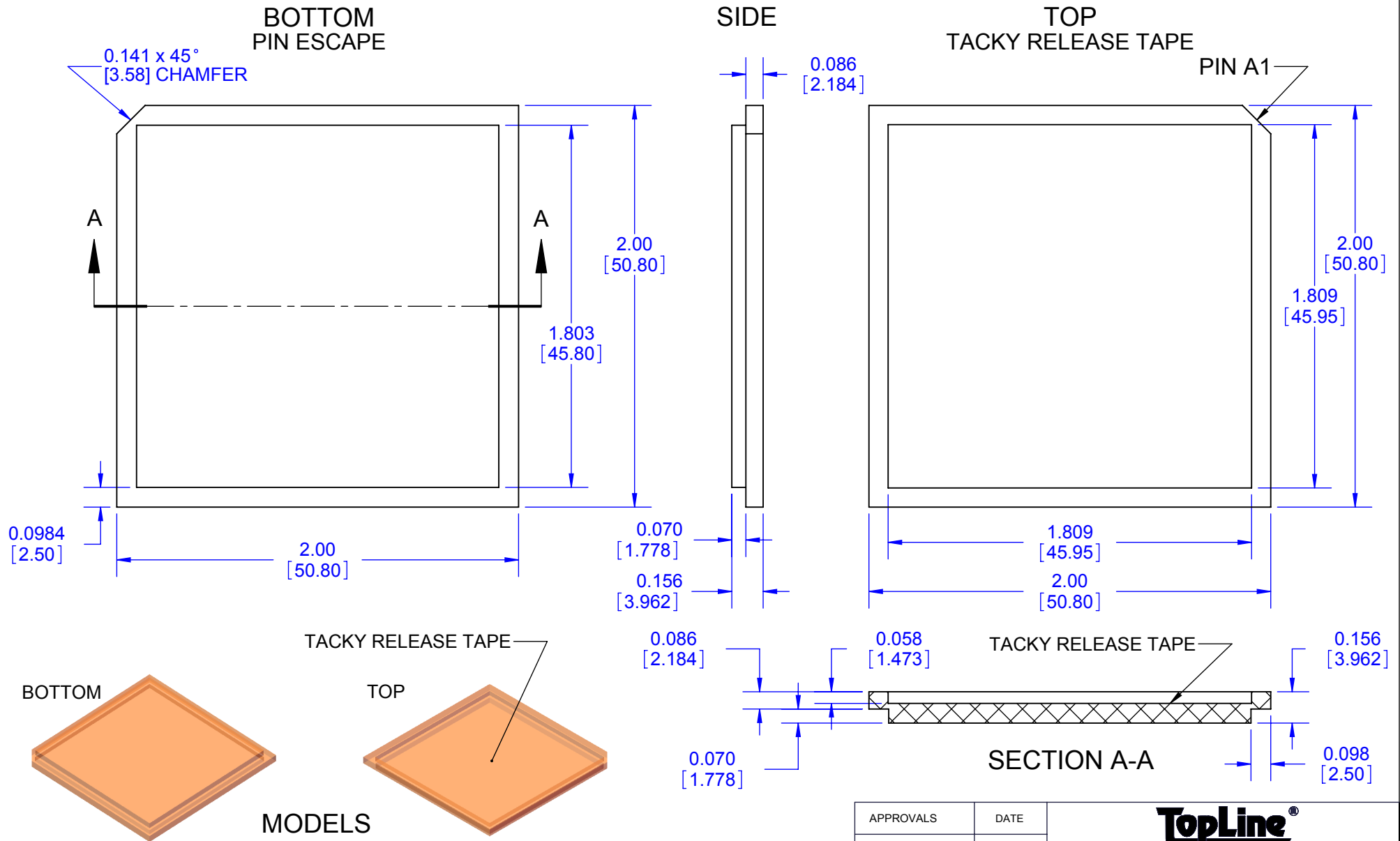

- NOTES:**
1. DIMENSIONS INCHES [MM].
 2. SHOWN WITHOUT HOLES FOR CLARITY.
 3. PIN-PACK™ IS TRADEMARK OF TOPLINE.
 4. PIN-PACK™ PATENT PENDING.

| | | | | | |
|-------------|----------|-----------------------------------------------|------|-------------|--------------|
| APPROVALS | DATE | TopLine® | | | |
| DRAWN T.Au | 10/29/14 | | | | |
| ENG M. Hart | 10/29/14 | TITLE PP1509 PIN-PACK™ CCGA COLUMN CARRIER | | | |
| MFG | | SCALE | SIZE | DRAWING NO. | REV |
| QA | | 3:2 | A | 001394 | A |
| CUST | | DO NOT SCALE DRAWING | | | SHEET 6 OF 8 |
| REVISED | | | | | |

TACKY RELEASE TAPE TOP VIEW

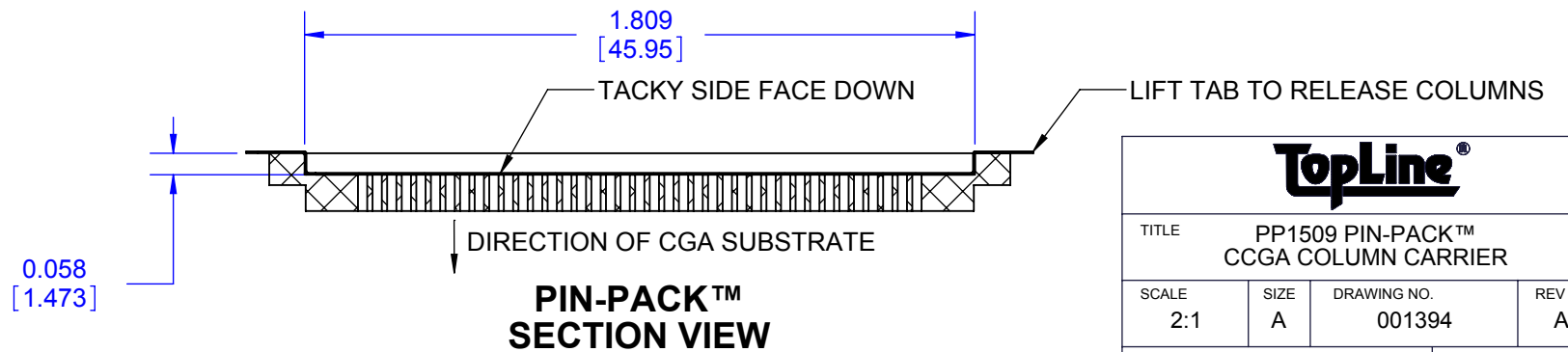
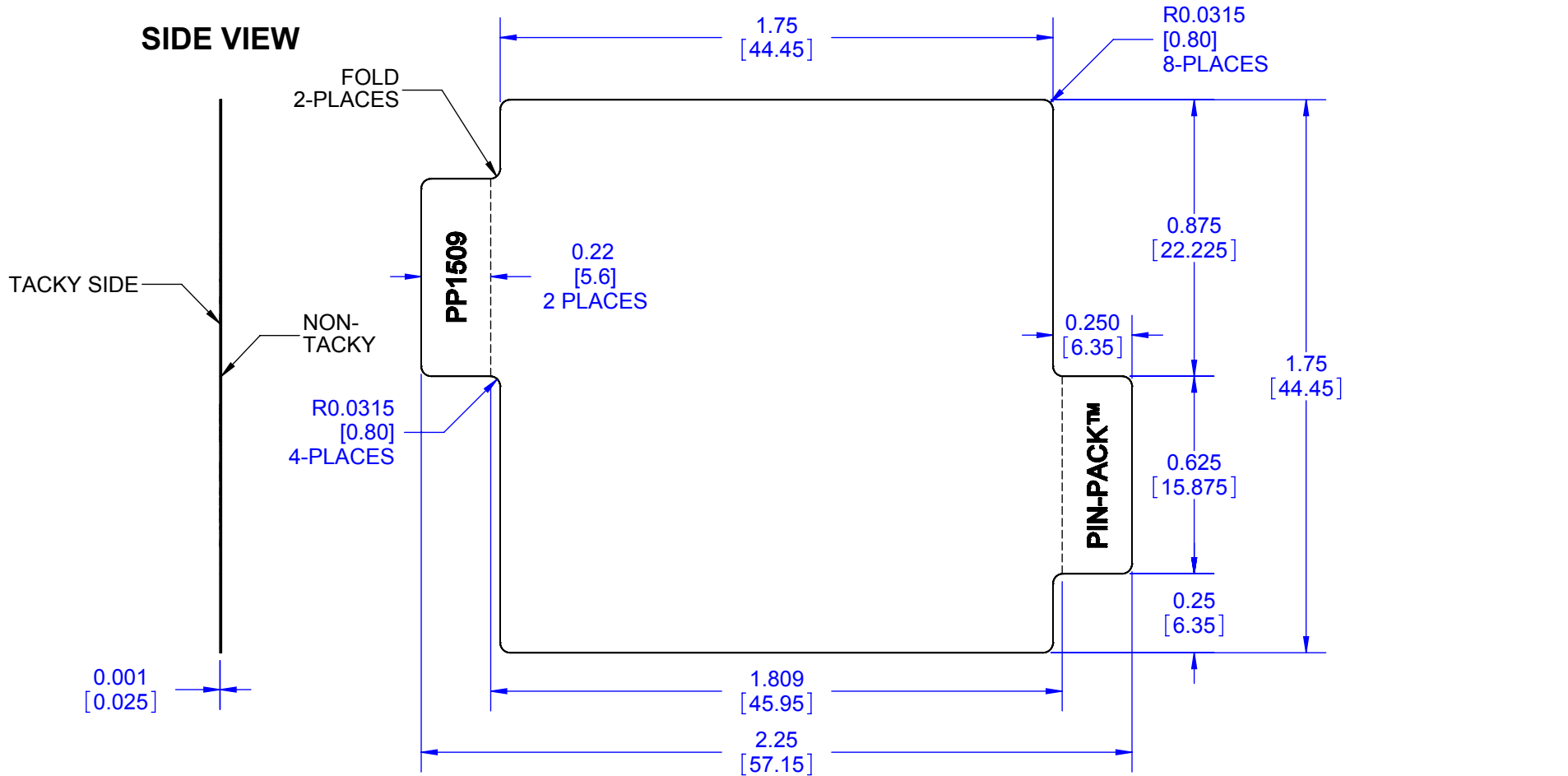

| | | | |
|--------------------------------------------------|-----------|-----------------------|--------------|
| TopLine® | | | |
| TITLE PP1509 PIN-PACK™ CCGA COLUMN CARRIER | | | |
| SCALE 2:1 | SIZE A | DRAWING NO. 001394 | REV A |
| DO NOT SCALE DRAWING | | | SHEET 7 OF 8 |

TACKY RELEASE TAPE MODEL

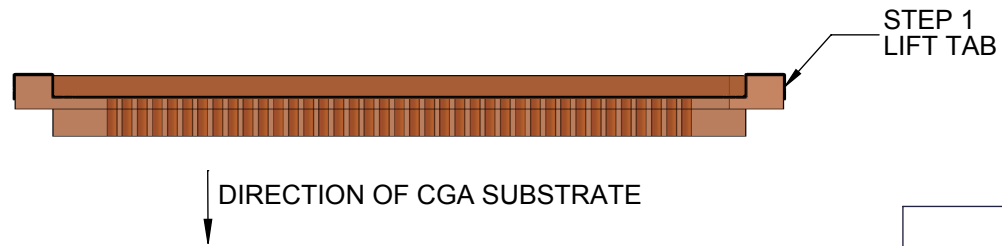
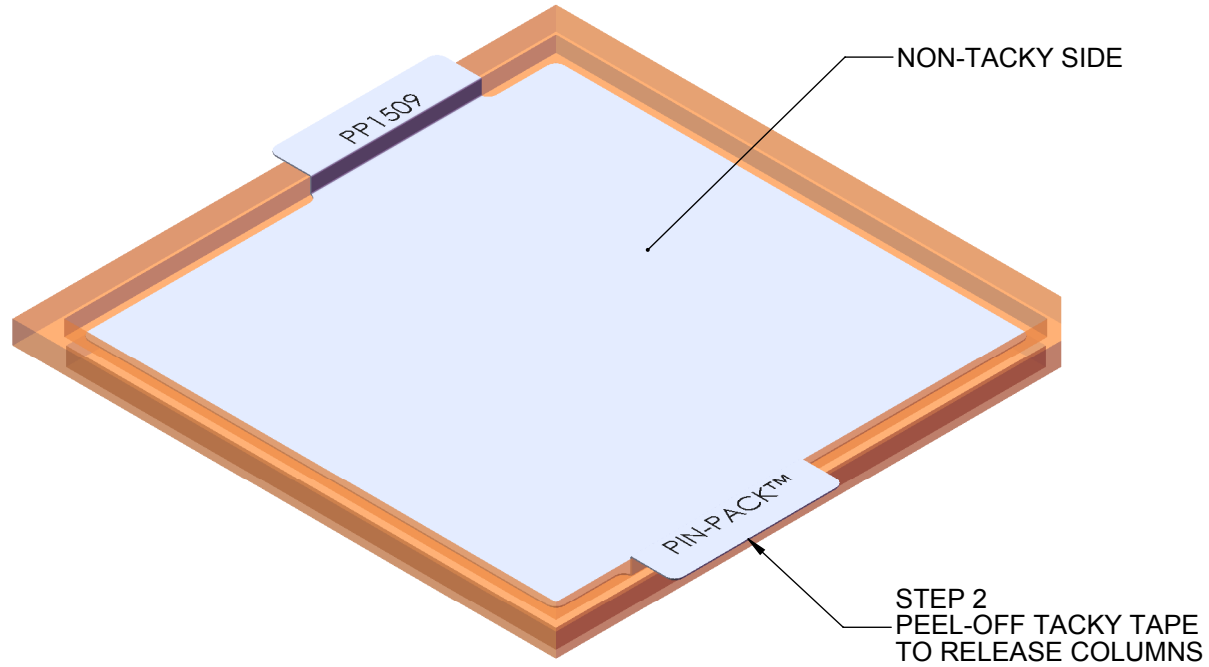

| | | | |
|--------------------------------------------------|------|-------------|--------------|
| TopLine® | | | |
| TITLE PP1509 PIN-PACK™ CCGA COLUMN CARRIER | | | |
| SCALE | SIZE | DRAWING NO. | REV |
| 2:1 | A | 001394 | A |
| DO NOT SCALE DRAWING | | | SHEET 8 OF 8 |