

TOP VIEW

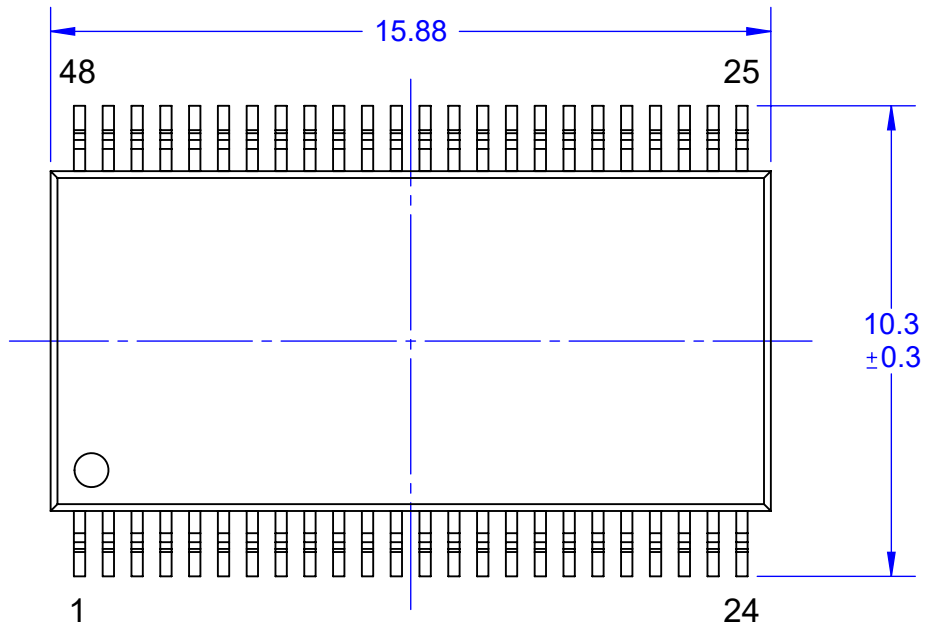

DETAIL A

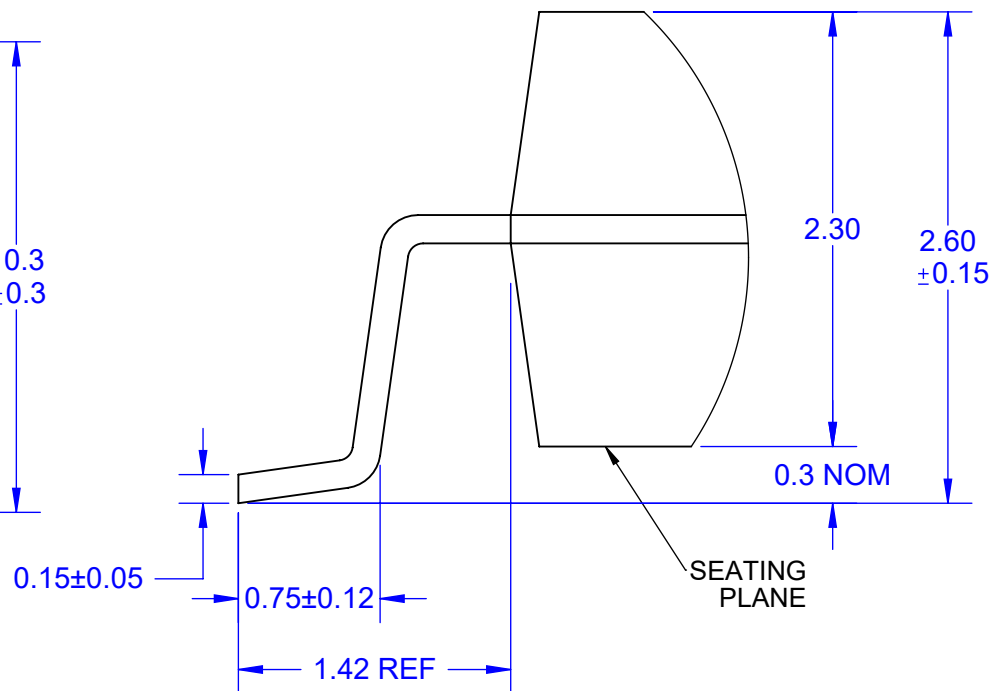

SIDE VIEW

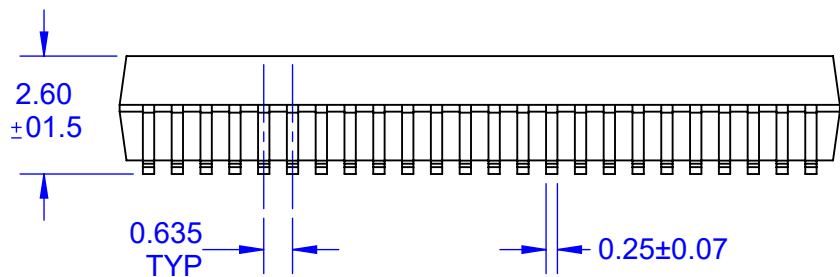

END VIEW

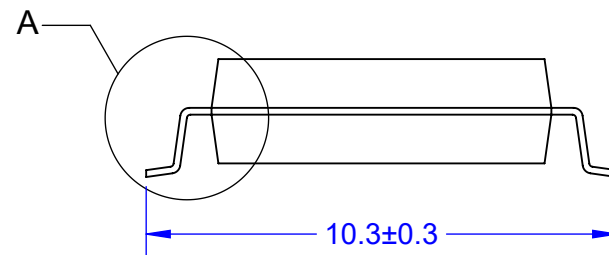

Notes: (Unless Otherwise Specified)

1. DIMENSIONS: MM.
2. SEE DAISY CHAIN JUMPER DIAGRAMS (PAGE 2).
3. SEE PART NUMBER CONFIGURATION (PAGE 3).
4. RECOMMENDED PC BOARD LAYOUT PATTERN (PAGE 5).

APPROVALS	DATE	TopLine®			
DRAWN T.Au	5/29/2023				
ENG M. Hart	5/29/2023	TITLE SSOP48 OUTLINE PACKAGE			
MFG		SCALE	SIZE	DRAWING NO.	REV
QA		6:1	A	124802	A
CUST		DO NOT SCALE DRAWING			SHEET 1 OF 5
REVISED					

**INTERNAL WIRING CIRCUIT (JUMPER)
DAISY CHAIN PART NUMBER SUFFIX TOP VIEW**

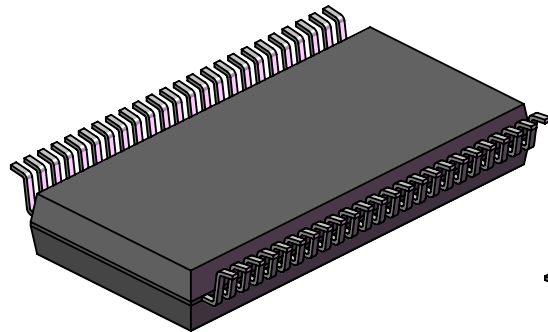
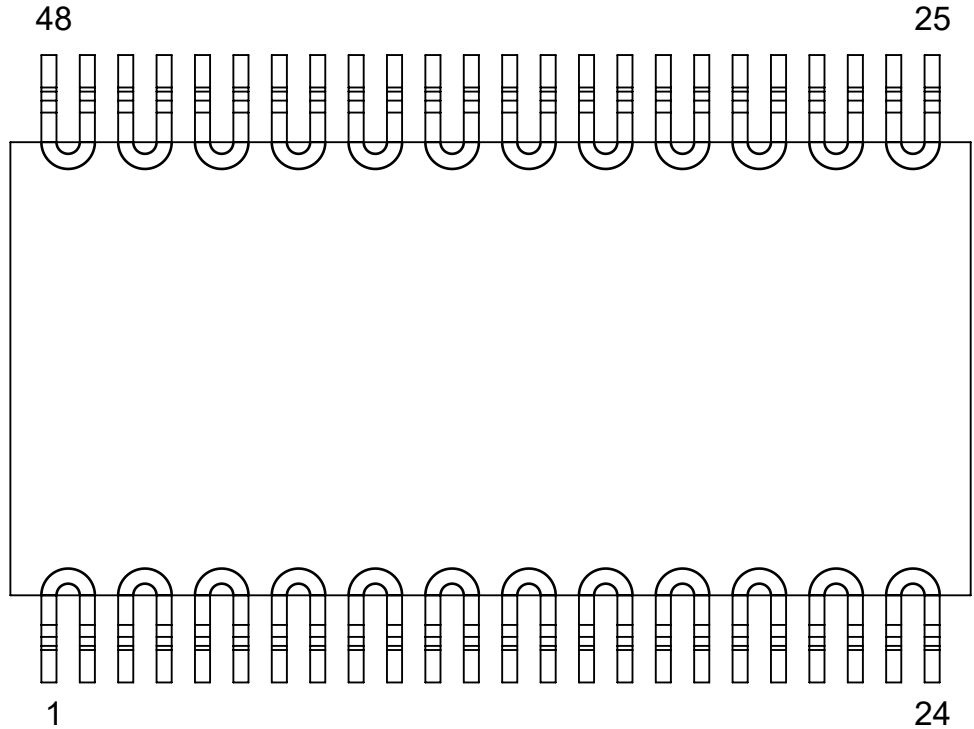

BOTTOM

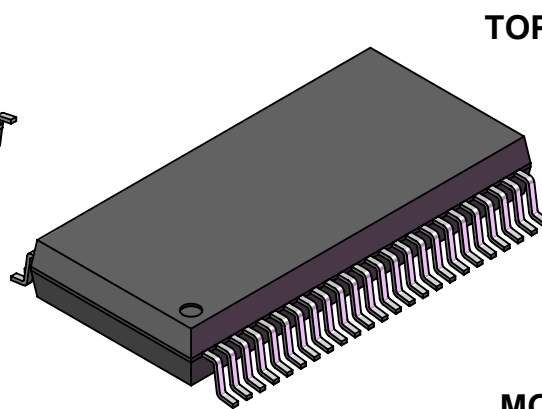

TOP

MODEL

TopLine®			
TITLE		SSOP48 OUTLINE PACKAGE	
SCALE	SIZE	DRAWING NO.	REV
8:1	A	124802	A
DO NOT SCALE DRAWING			SHEET 2 OF 5

PART NUMBERING SYSTEM

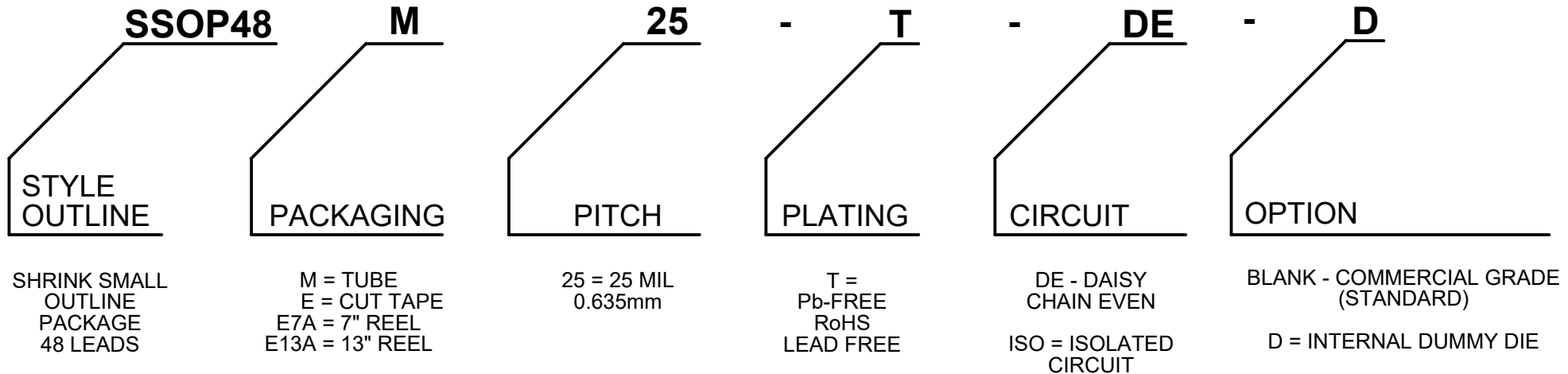

PART NUMBER	SHORTED PINS	NOTES	RoHS Pb-FREE	PACKAGING
SSOP48M48-T	N/A	DUMMY	YES	TUBE
SSOP48M48-T-ISO	NONE	FULLY ISOLATED	YES	TUBE
SSOP48M48-T-DE-D	1~2, 3~4, 5~6, 7~8, 9~10, 11~12, 13~14, 15~16, 17~18, 19~20, 21~22, 23~24, 25~26, 27~28, 29~30, 31~32, 33~34, 35~36, 37~38, 39~40, 41~42, 43~44, 45~46, 47~48	DAISY CHAIN	YES	TUBE
SSOP48E48-T-DE-D	1~2, 3~4, 5~6, 7~8, 9~10, 11~12, 13~14, 15~16, 17~18, 19~20, 21~22, 23~24, 25~26, 27~28, 29~30, 31~32, 33~34, 35~36, 37~38, 39~40, 41~42, 43~44, 45~46, 47~48	DAISY CHAIN	YES	REEL

TopLine®			
TITLE SSOP48 OUTLINE PACKAGE			
SCALE NONE	SIZE A	DRAWING NO. 124802	REV A
DO NOT SCALE DRAWING			SHEET 3 OF 5

TAPE SPECIFICATION SSOP48 SURFACE MOUNT DEVICE

TAPE DIMENSIONS

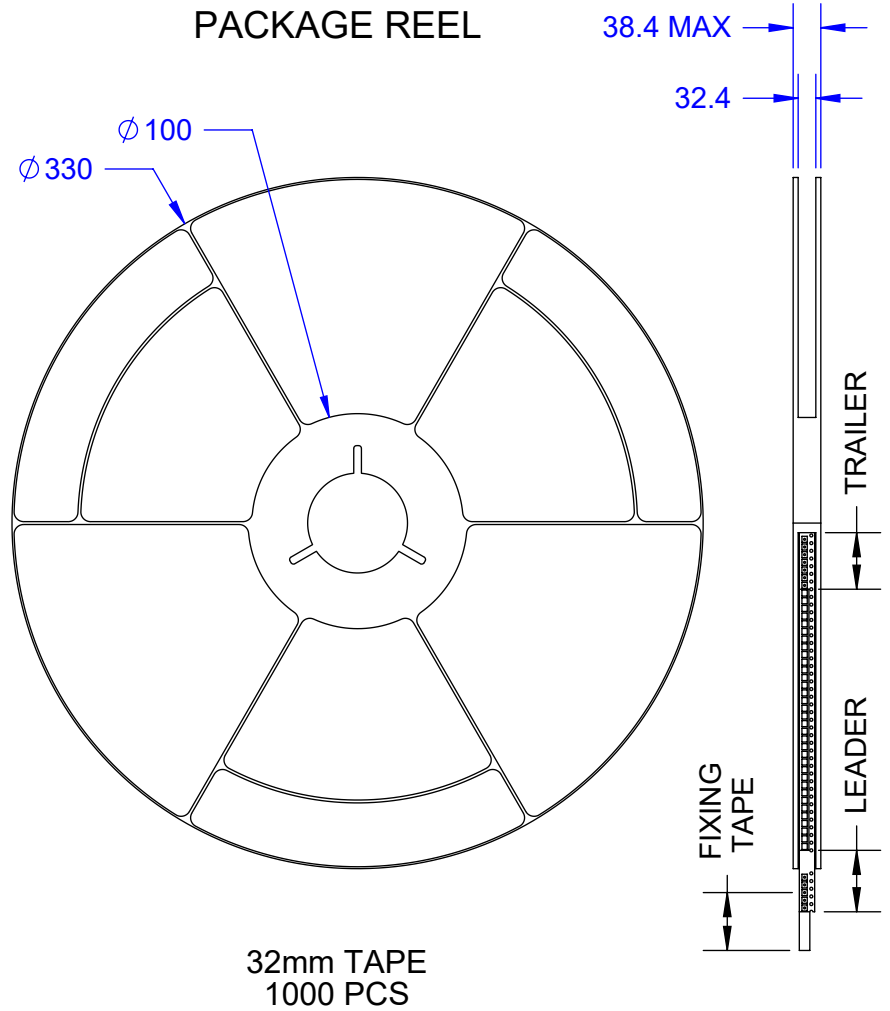
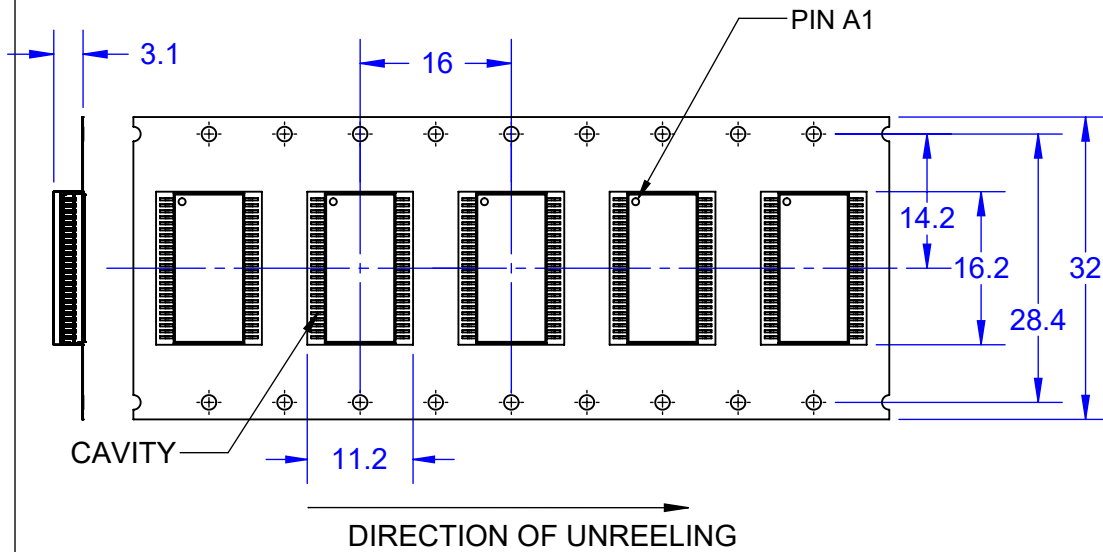

ALL DIMENSIONS: mm.

PRELIMINARY

TopLine[®]			
TITLE SSOP48 OUTLINE PACKAGE			
SCALE 3:2	SIZE A	DRAWING NO. 124802	REV A
DO NOT SCALE DRAWING			SHEET 4 OF 5

PCB BOARD LAND PATTERN

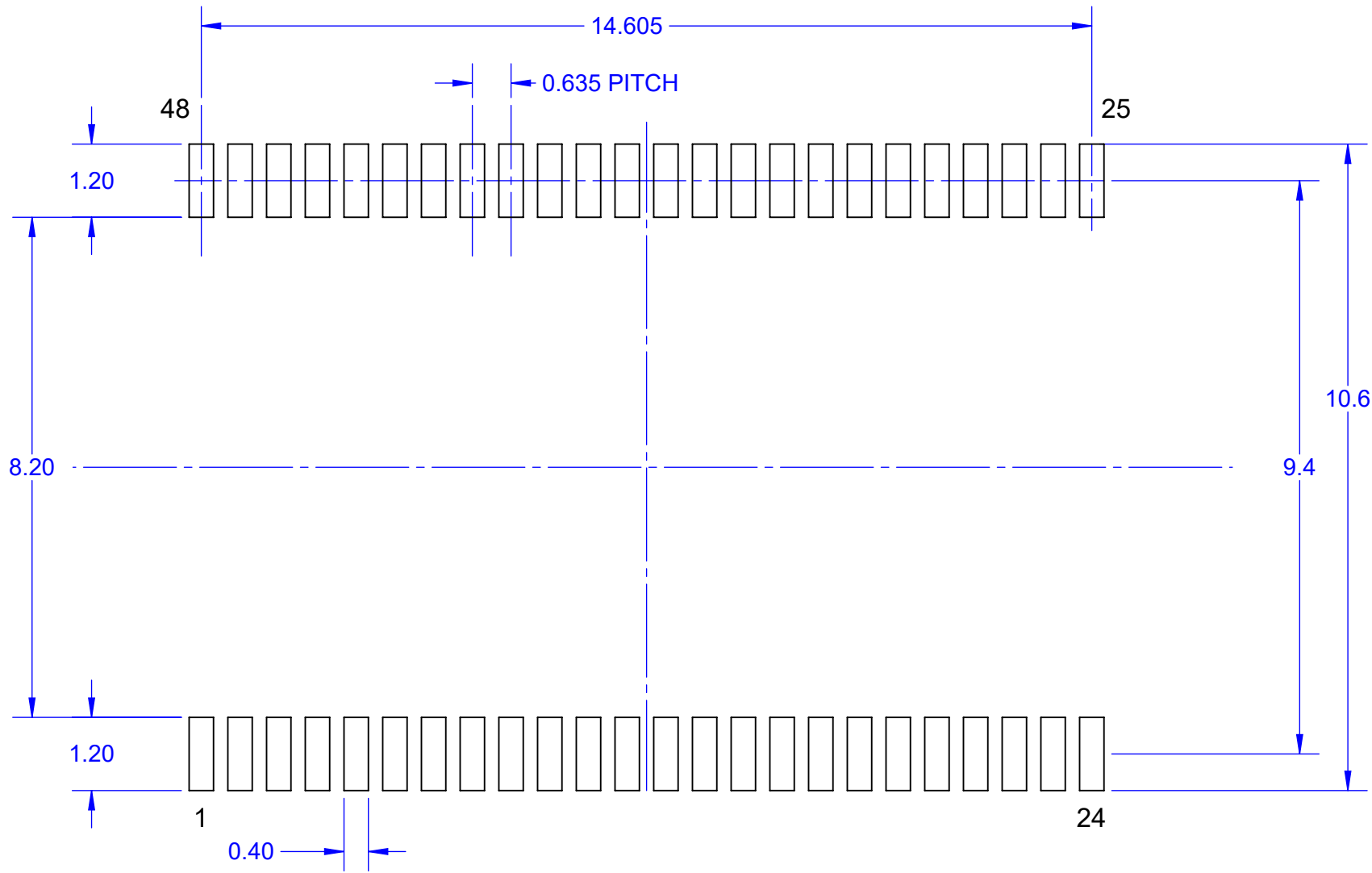

- Notes: (Unless Otherwise Specified)
1. DIMENSIONS: MM.
 2. PCB BOARD DIMENSIONS ARE PRESENTED ONLY AS A GUIDELINE.
 3. DESIGNERS SHOULD USE THEIR OWN EXPERIENCE WHEN DESIGNING PCB.

TopLine[®]			
TITLE		SSOP48 OUTLINE PACKAGE	
SCALE	SIZE	DRAWING NO.	REV
10:1	A	124802	A
DO NOT SCALE DRAWING			SHEET 5 OF 5