

<u>BALLS</u>	<u>PITCH</u>	<u>SIZE</u>	<u>MATRIX</u>	<u>ROWS</u>	<u>CENTER</u>	<u>MAT'L</u>
6	0.5mm	1.5 x 1.0mm	2 x 3	full	na	Wafer Level Si

BALL VIEW

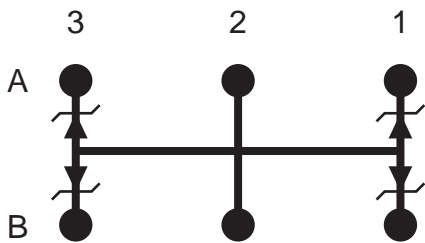

BOTTOM SIDE (TOP X-RAY VIEW)

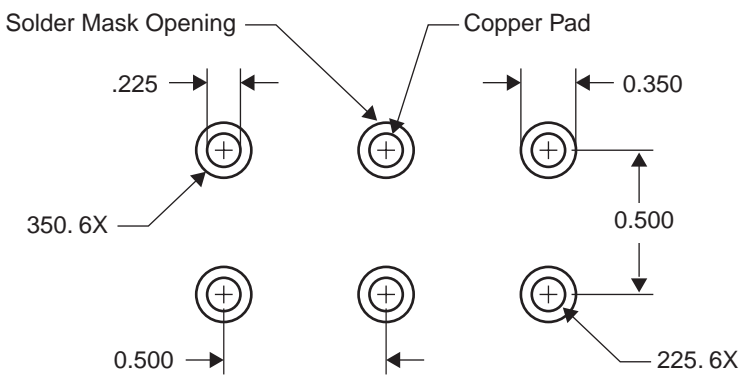
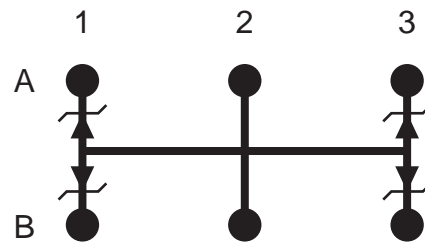

TEST VEHICLE BOARD

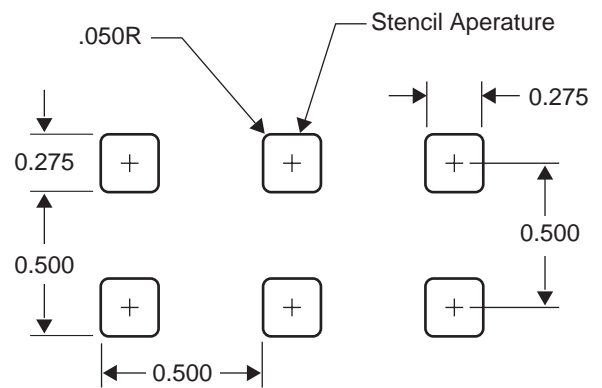

RECOMMENDED STENCIL

WLP6T.5C-DC023D Lead Free



<u>BALLS</u>	<u>PITCH</u>	<u>SIZE</u>	<u>MATRIX</u>	<u>ROWS</u>	<u>CENTER</u>	<u>MAT'L</u>	TEL 1-800-776-9888
6	0.5mm	1.5 x 1.0mm	2 x 3	full	na	Wafer Level Si	info@topline.tv

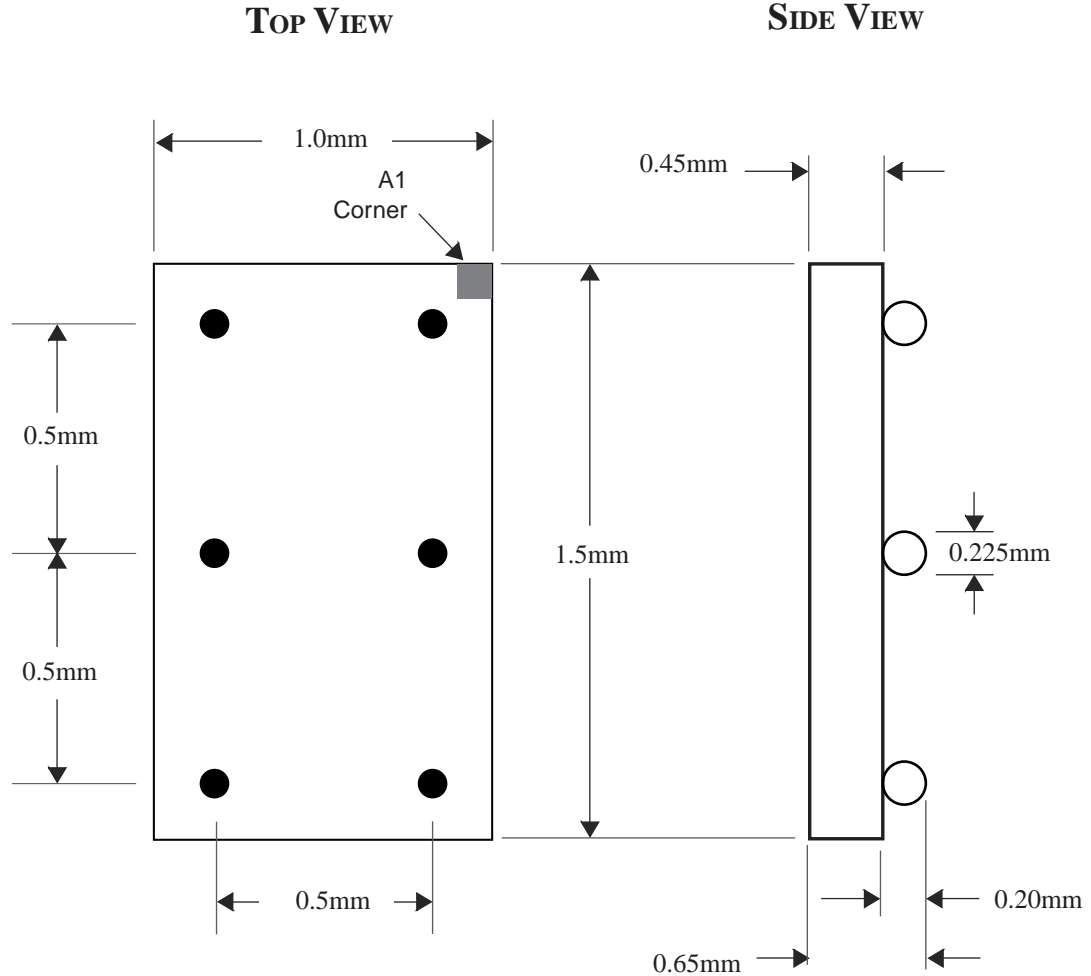

NOTES		REVISIONS		
Note 1	Top marked F45U	Rev	Date	Changes
Note 2	Ball A1 locator mark positioned in corner			
Note 3	Ball Material: Sn95.5/Ag3.8/Cu0.7			
Note 4	Substrate Material: Si			
Note 5	JEDEC MO-211 BB			
		PACKAGING TRAYS		
		Reel Package, Plastic Tape 2mm pitch Reel Quantity: 3000 and 500 - Bulk Tray 100pcs		