

TOP VIEW

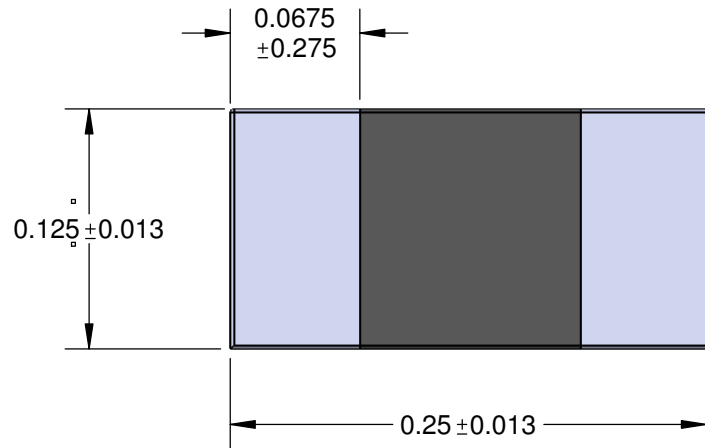

STRUCTURE

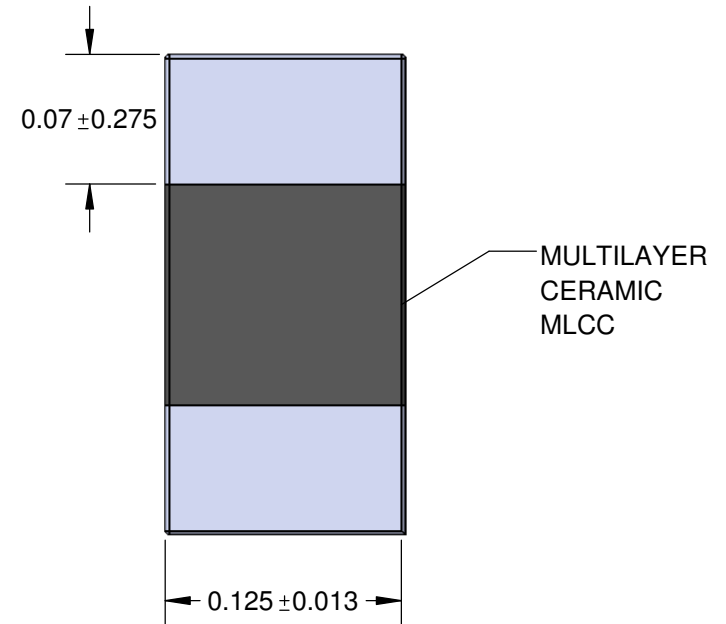

RECOMMENDED PCB PATTERN

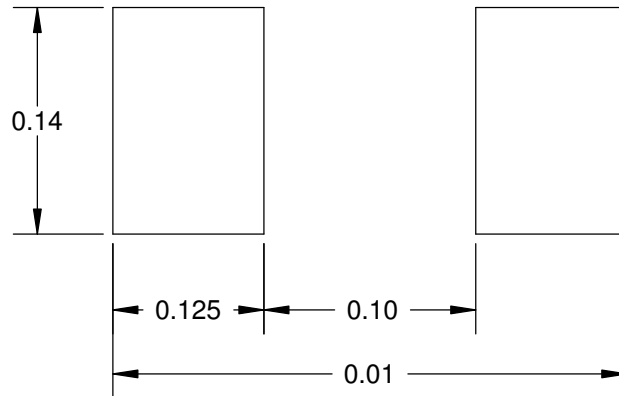

- NOTES:
 1. DIMENSIONS IN mm.
 2. TERMINATION: Tin (Sn).
 3. Pb-FREE AND HALOGEN FREE.

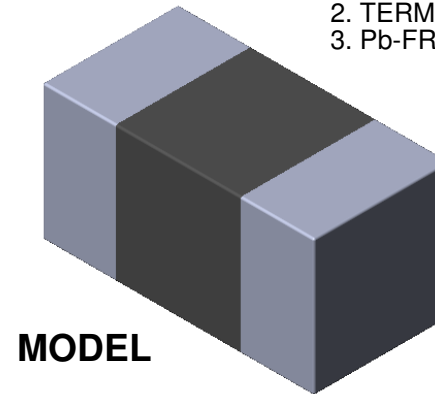

MODEL

PCB DIMENSIONS ARE REPRESENTED ONLY AS A GUIDELINE. DESIGNERS SHOULD USE THEIR OWN KNOWLEDGES BASE WHEN DESIGNING THE PCB.

APPROVALS	DATE	TopLine®			
DRAWN T. Au	12/05/2017				
ENG M. Hart	12/05/2017	TITLE SC008004			
MFG		SMT CAPACITOR			
QA		SCALE	SIZE	DRAWING NO.	REV
CUST		250:1	A	128043	A
REVISED		DO NOT SCALE DRAWING			SHEET 1 OF 2

W4P1 CARRIER TAPE DIMENSION

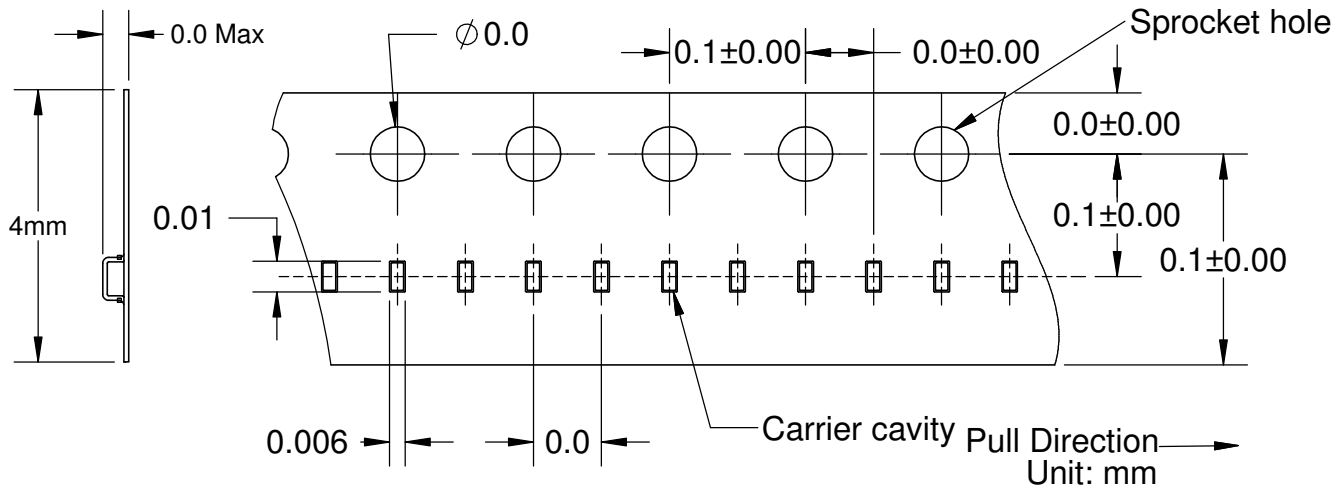

W4P1 TAPE PART NUMBER SYSTEM

SC	008004	E7A	W4P1
CAPACITOR		PACK CODE	
SIZE CODE 0.25 x 0.10mm		TAPE Width W4 = 4mm Pitch P1 = 1mm	

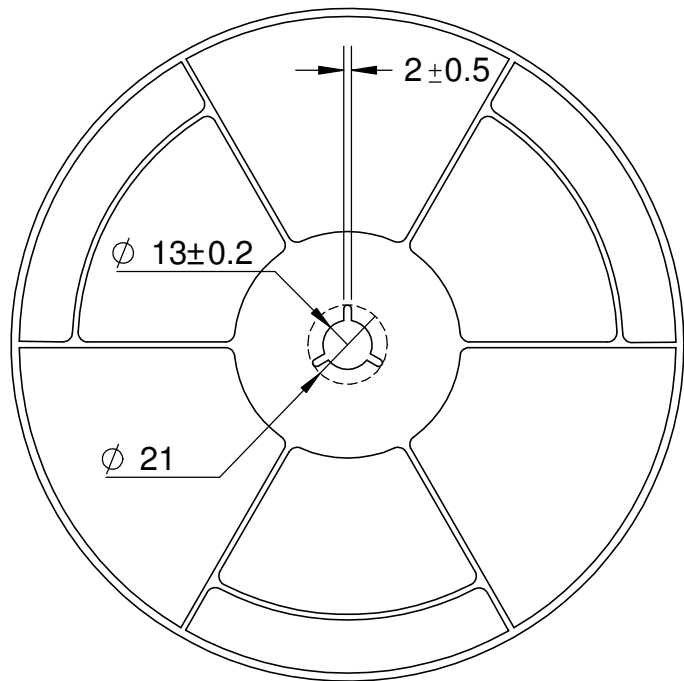

REEL DIMENSIONS

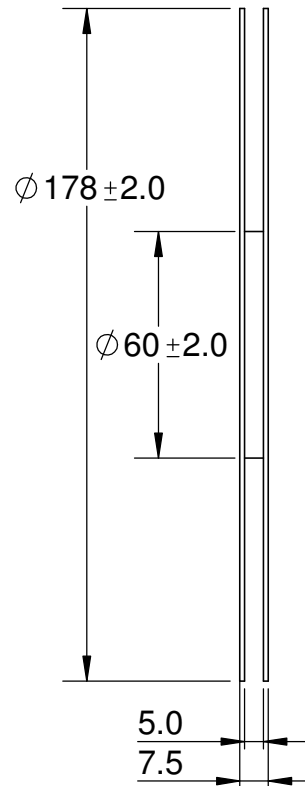

PACK CODE		
CODE	QTY	PACKAGE
E7A	50,000	REEL
E7B	25,000	REEL
E7C	10,000	REEL
E7D	5,000	REEL
E7F	1,000	REEL

TopLine®			
TITLE SC008004 SMT CAPACITOR			
SCALE	SIZE A	DRAWING NO. 128043	REV A
DO NOT SCALE DRAWING			SHEET 2 OF 2