

TOP VIEW

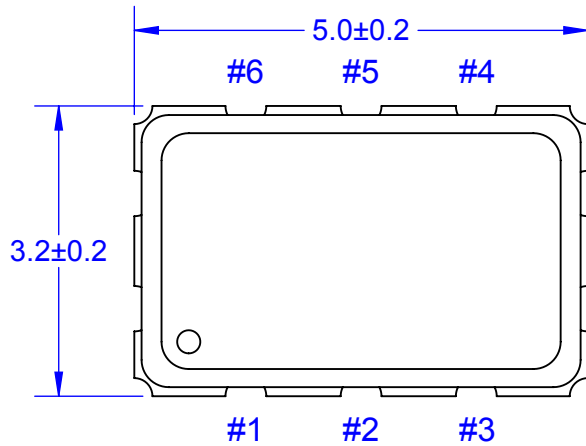

BOTTOM VIEW

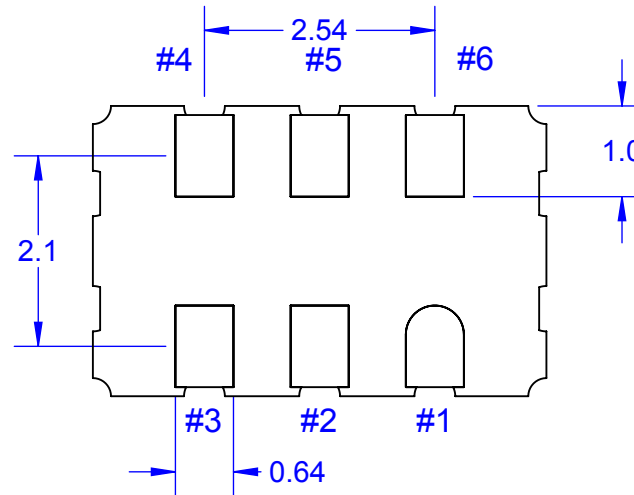

SIDE VIEW

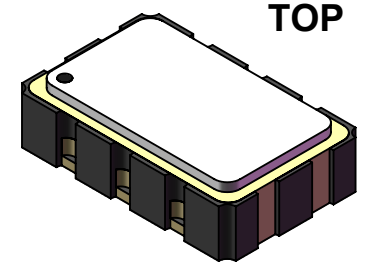
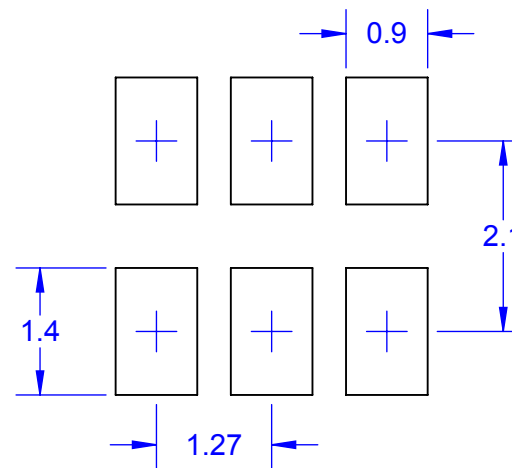
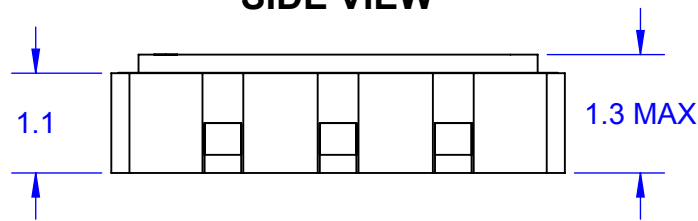

TOP

MODEL

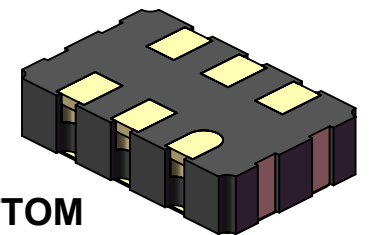

BOTTOM

PCB LAYOUT

PART NUMBER	DAISY CHAIN CONNECTION
LCC6-5.0x3.2-DC1346	PIN 1~2, 3~4, 5~6
LCC6-5.0x3.2	DUMMY PACKAGE UNDEFINED

- NOTES: (Unless Otherwise Specified)
1. DIMENSIONS IN mm.
 2. DAISY CHAIN CONNECTION INSIDE PACKAGE.
 3. PLATING: Ni 1.27~8.89µm Au 0.30~1.00µm.

APPROVALS	DATE				
DRAWN T.Au	07/04/15				
ENG M. Hart	07/04/15	TITLE LCC6 - 5.0 x 3.2 DAISY CHAIN			
MFG		SCALE 12:1	SIZE A	DRAWING NO. 127032	REV A
QA		DO NOT SCALE DRAWING			SHEET 1 OF 2
CUST					
REVISED					

DAISY CHAIN PATTERN

**PACKAGE
TOP VIEW**

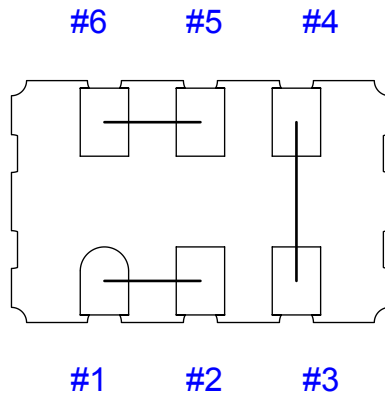

PC BOARD

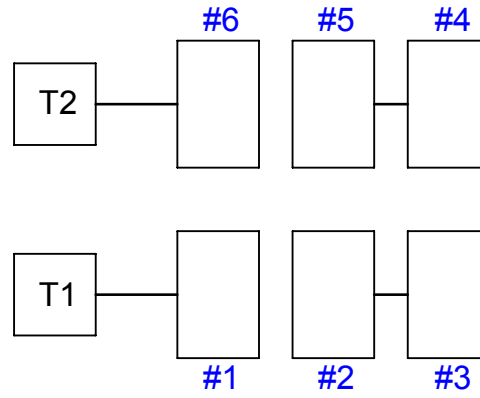

AFTER MOUNTING

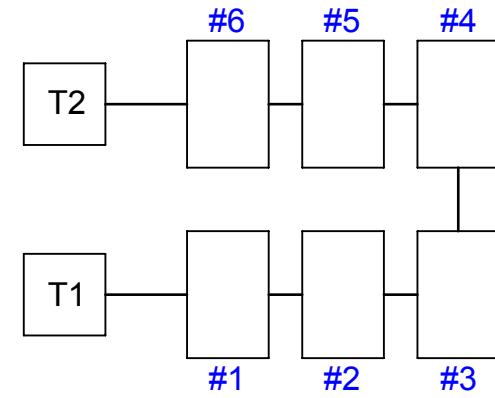

APPROVALS	DATE	TopLine®			
DRAWN T. Au	07/04/15				
ENG M. Hart	07/04/15	TITLE LCC6 - 5.0 x 3.2 DAISY CHAIN			
MFG		SCALE	SIZE	DRAWING NO.	REV
QA		12:1	A	127032	A
CUST		DO NOT SCALE DRAWING			SHEET 2 OF 2
REVISED					