

SIDE

TOP

SIDE

BOTTOM

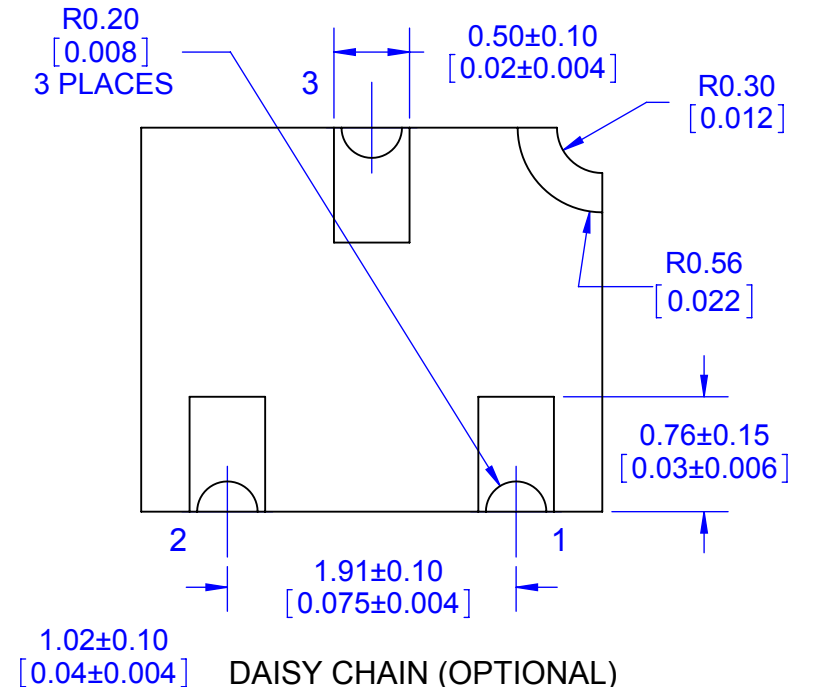
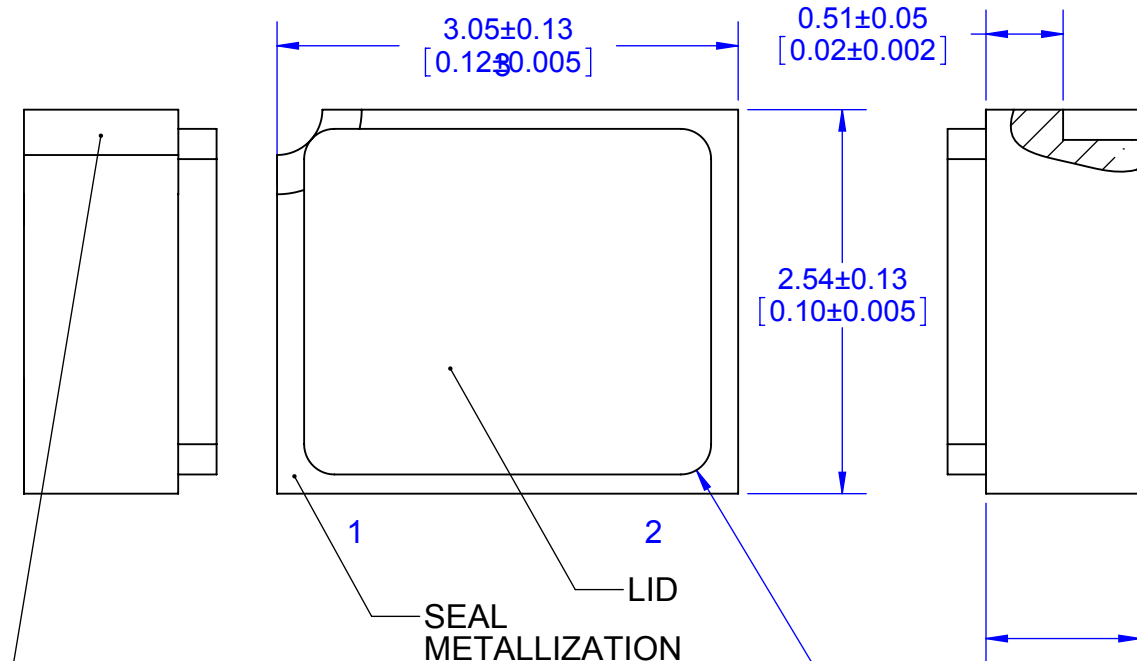

THIS METALLIZATION TO BE ELECTRICALLY CONNECTED TO THE SEAL RING

$R0.20$ [0.008] 4 PLACES

DAISY CHAIN (OPTIONAL)

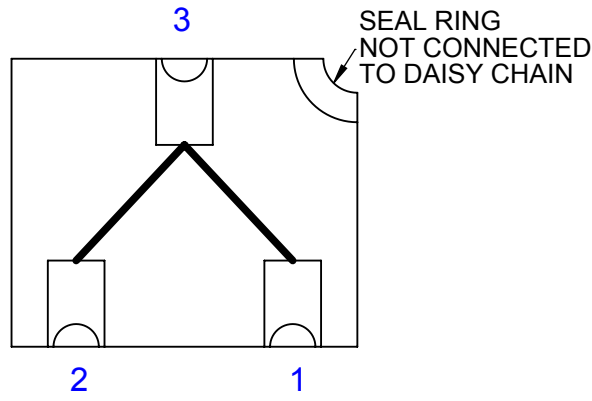

PART NUMBER	LID	PLATING	DAISY CHAIN
LCC3R.12X.10R-N	OPEN UNSEALED	NiAu	NO
LCC3R.12X.10R	SEALED	NiAu	NO
LCC3R.12X.10R-SC	SEALED	SnPb	NO
LCC3R.12X.10R-DC123	SEALED	NiAu	YES
LCC3R.12X.10R-DC123-SC	SEALED	SnPb	YES

Note:
 GOLD PLATE 1.5µm MIN
 OVER 2.0µm NICKEL.
 Except CASTELLATION

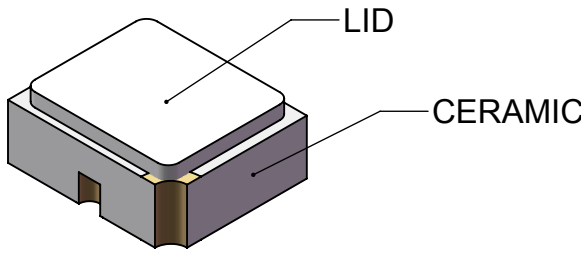
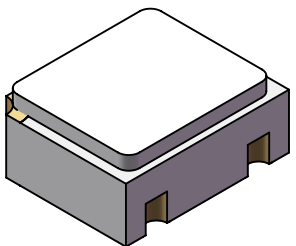

APPROVALS	DATE	TopLine®			
DRAWN T.Au	10/20/14				
ENG M. Hart	10/20/14	TITLE LCC3R GROUND SEAL RING			
MFG		SCALE 20:1	SIZE A	DRAWING NO. 140301	REV A
QA		DO NOT SCALE DRAWING			SHEET 1 OF 1
CUST					
REVISED					