

TOP VIEW

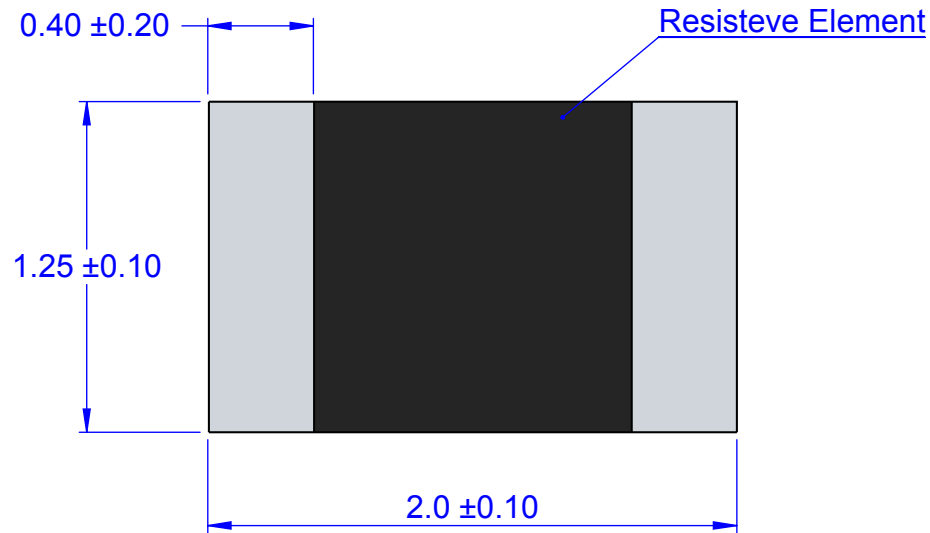

RECOMMENDED PCB PATTERN

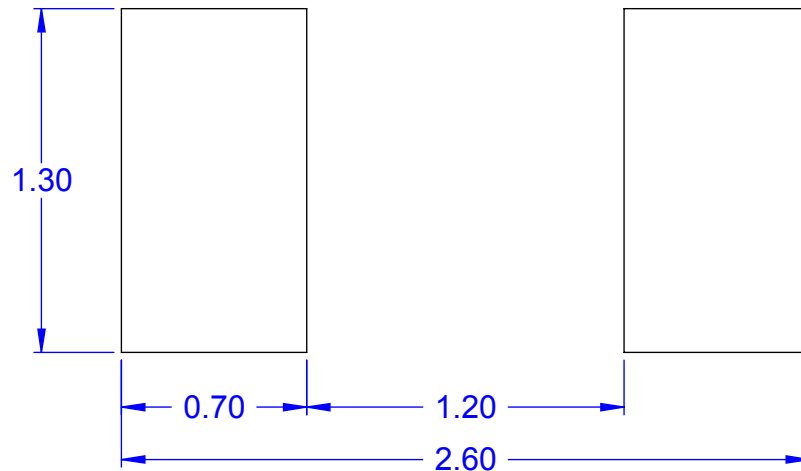

PCB DIMENSIONS ARE PRESENTED ONLY AS A GUIDELINE. DESIGNERS SHOULD USE THEIR OWN KNOWLEDGE BASE WHEN DESIGNING THE PCB.

STRUCTURE

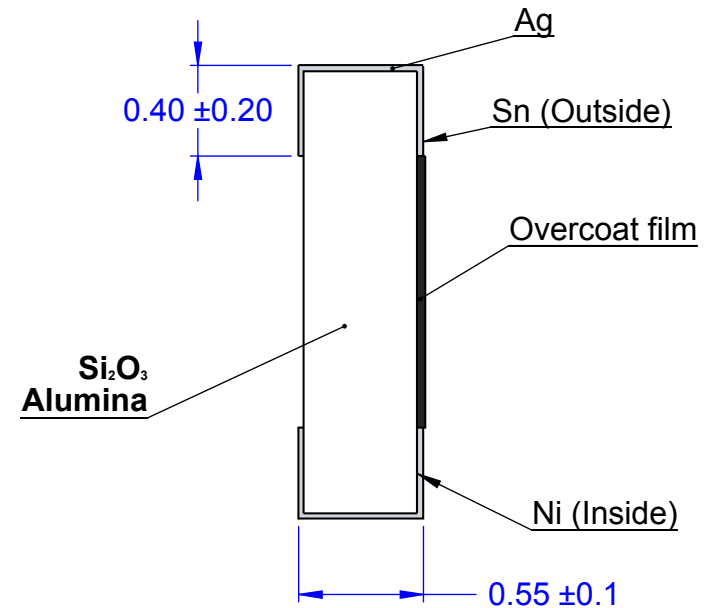

NOTES:

1. DIMENSIONS IN mm.
2. TERMINATION: Tin (Sn).
3. Pb-FREE AND HALOGEN FREE.

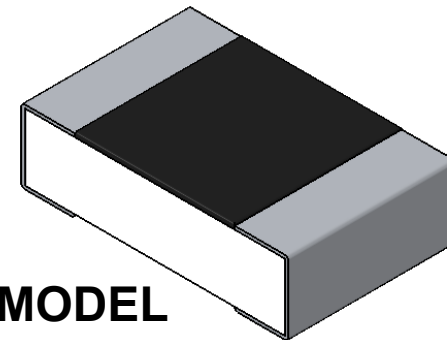

MODEL

| | | | | | |
|-------------|----------|------------------------------|-----------|-----------------------|--------------|
| APPROVALS | DATE | TopLine® | | | |
| DRAWN T. Au | 08/03/12 | | | | |
| ENG M. Hart | 08/03/12 | TITLE SR0805 SMT RESISTOR | | | |
| MFG | | SCALE | SIZE A | DRAWING NO. 120802 | REV A |
| QA | | | | | |
| CUST | | DO NOT SCALE DRAWING | | | SHEET 1 OF 2 |
| REVISED | | | | | |

W8P4 CARRIER TAPE DIMENSION

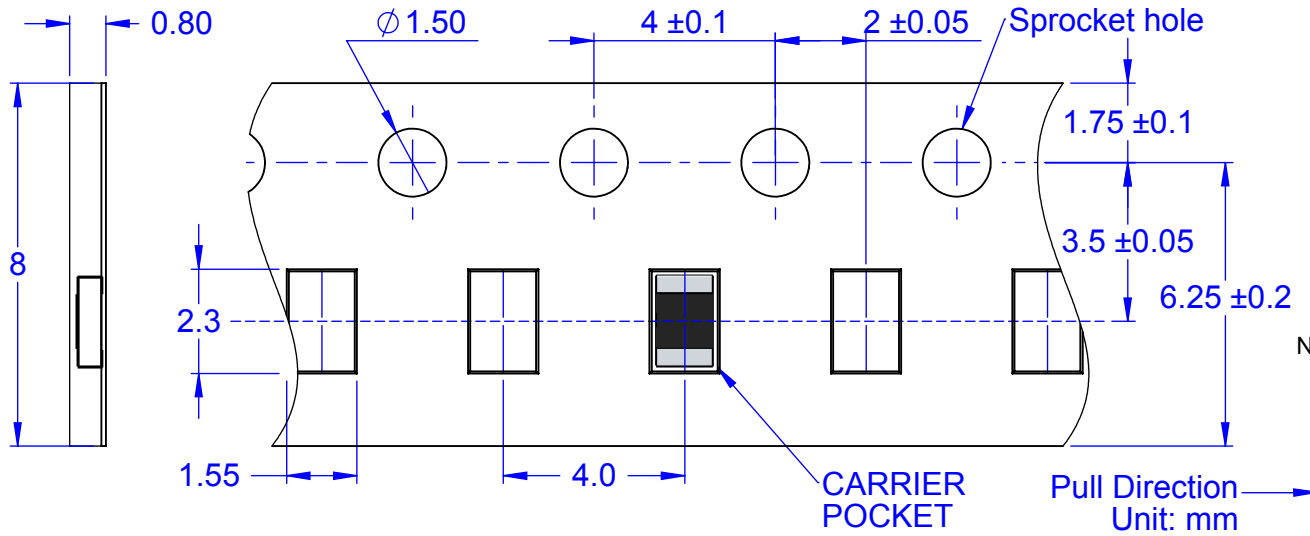

PART NUMBER SYSTEM

SR 0805 P7A - ZERO - TIN

RESISTOR PACK CODE < 50mΩ

SIZE CODE TERMINATION Sn (TIN)

2.0 x 1.25mm

NOTE: For dummy resistor replace ZERO with blank

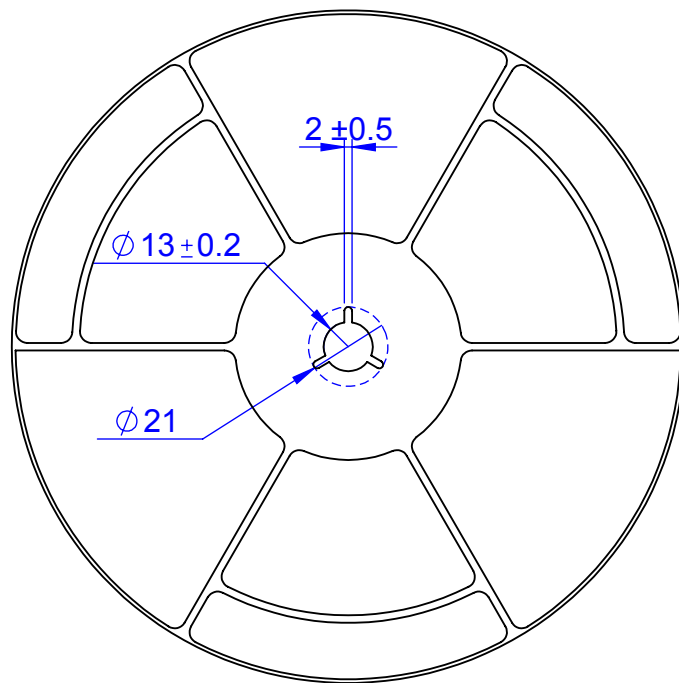

REEL DIMENSIONS

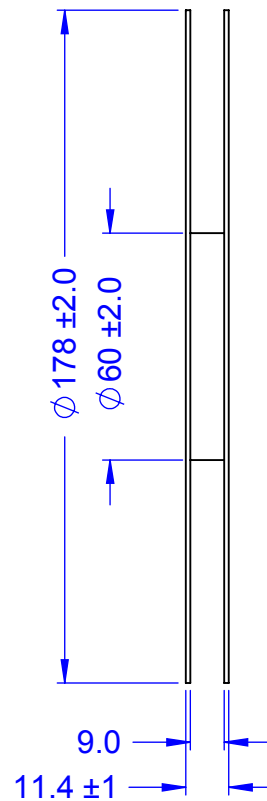

PACK CODE

| CODE | QTY | PACKAGE |
|------|-------|---------|
| P7A | 5,000 | REEL |
| P4A | 1,000 | REEL |

| APPROVALS | DATE |  | | | |
|-------------|----------|---|--|--------|--------------------|
| DRAWN T. Au | 08/03/12 | TITLE SR0805 SMT RESISTOR | | | |
| ENG M. Hart | 08/03/12 | SCALE | | SIZE A | DRAWING NO. 120802 |
| MFG | | | | REV A | |
| QA | | | | | |
| CUST | | | | | |
| REVISED | | DO NOT SCALE DRAWING | | | SHEET 2 OF 2 |