

TOP

SIDE

BOTTOM

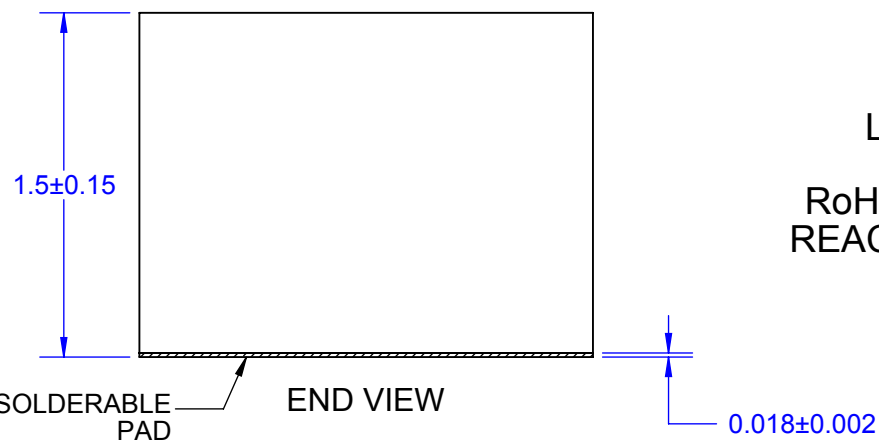
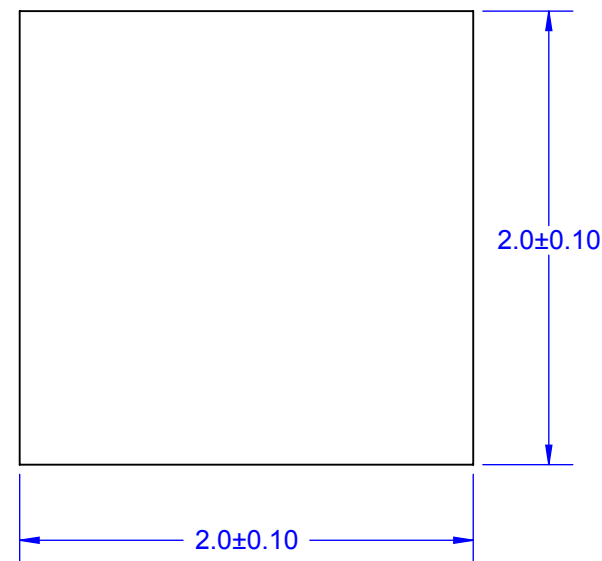
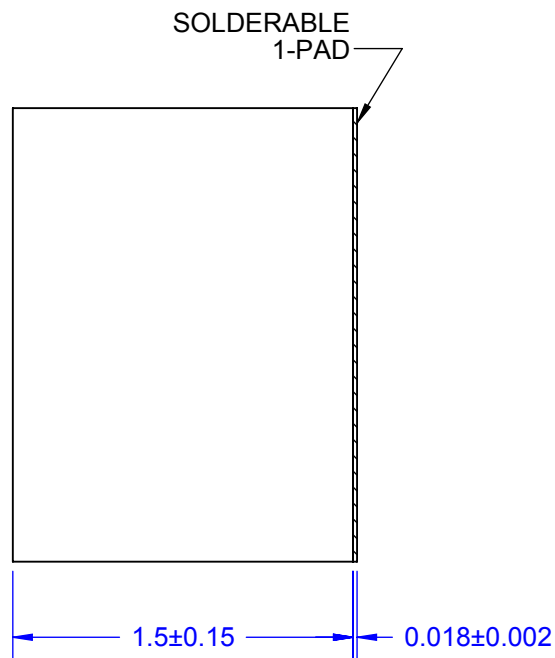
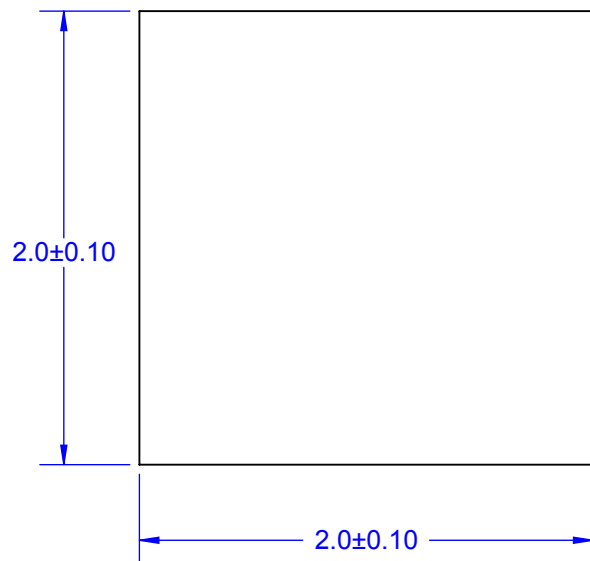

LEAD FREE
Pb-FREE
RoHS COMPLIANT
REACH COMPLIANT

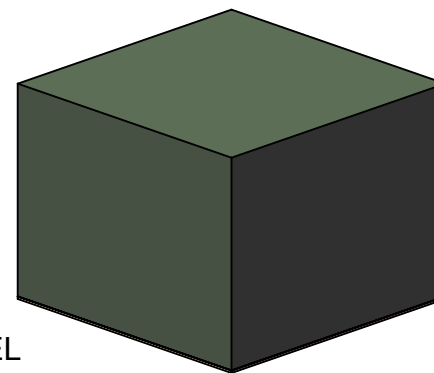

MODEL

Notes: (Unless Otherwise Specified).

- 1) BODY: FR4 (OTHER AVAILABLE).
- 2) TERMINATION: COPPER 0.007-INCH (0.018mm) THICK.
- 3) PLATING: IMMERSION TIN (Sn100).
- 4) NO MARKINGS.
- 5) BOTTOM TERMINAL.
- 6) DIMENSIONS: INCH [MM].

APPROVALS	DATE	TopLine®			
DRAWN T.Au	09/05/14				
ENG M. Hart	09/05/14	TITLE NON-CONDUCTIVE SPACER SSL080860E7A-L-T			
MFG		SCALE	SIZE	DRAWING NO.	REV
QA		30:1	A	080860	A
CUST		DO NOT SCALE DRAWING			SHEET 1 OF 5
REVISED					

PC BOARD LAND PATTERN

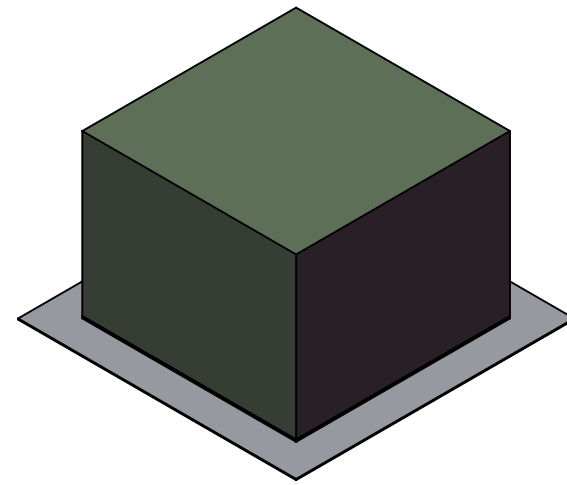
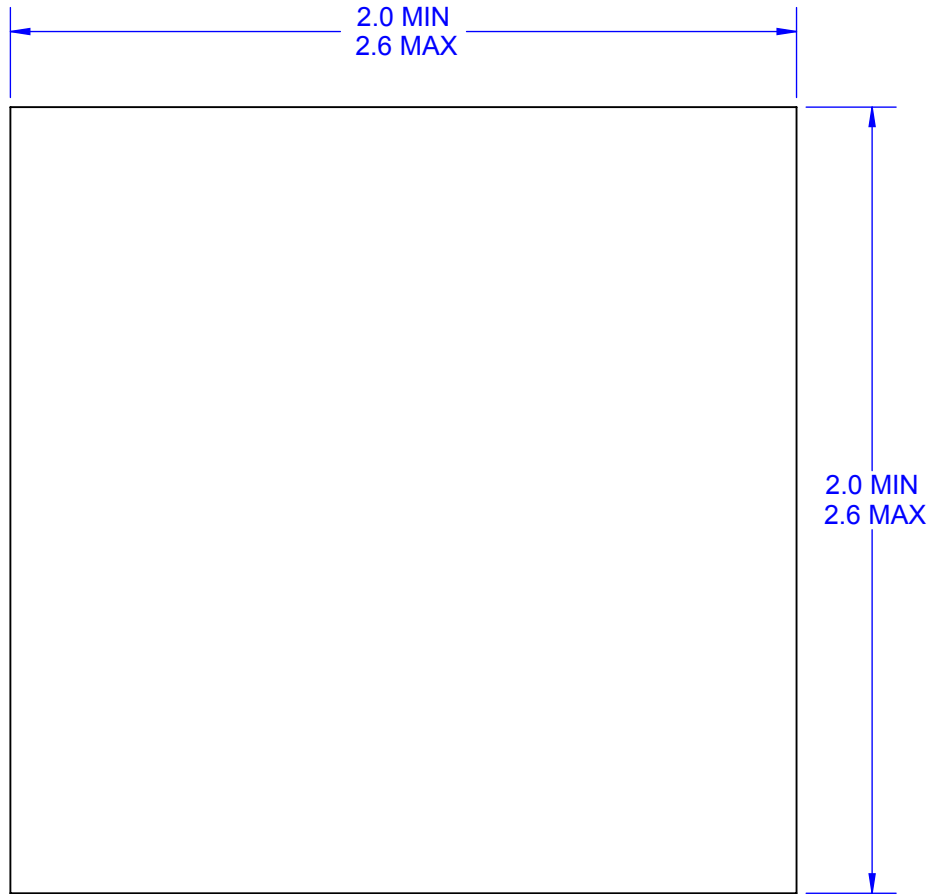

MODEL

Notes: (Unless Otherwise Specified).

- 1) DIMENSION IN mm.
- 2) PCB BOARD DIMENSIONS ARE PRESENTED ONLY AS A GUIDELINE.
DESIGNERS SHOULD USE THEIR OWN EXPERIENCE WHEN DESIGNING PCB.

TopLine®			
TITLE NON-CONDUCTIVE SPACER SSL080860E7A-L-T			
SCALE 40:1	SIZE A	DRAWING NO. 080860	REV A
DO NOT SCALE DRAWING		SHEET 2 OF 5	

PART NUMBERING SYSTEM

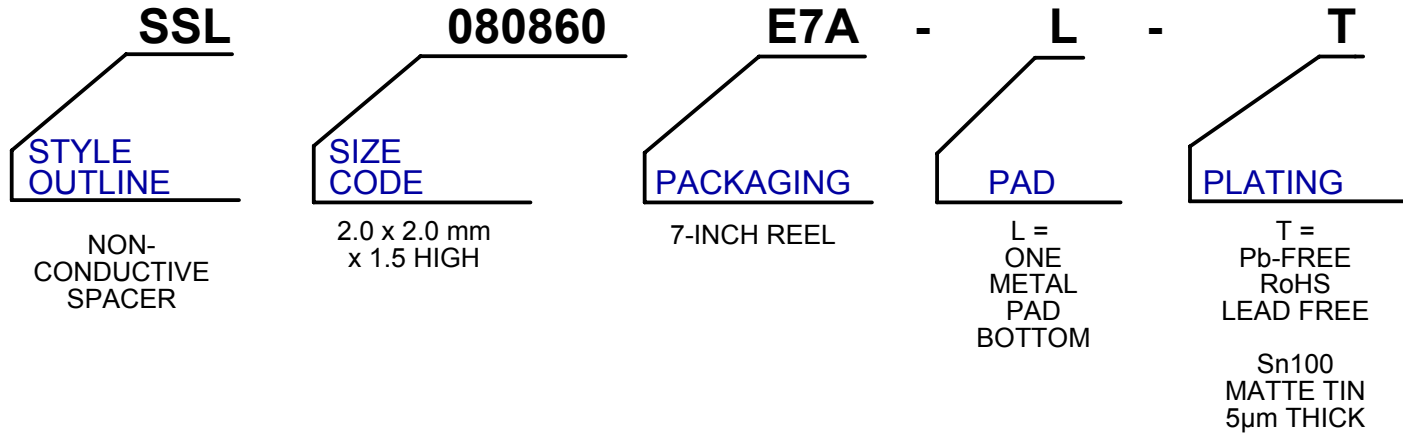

PART NUMBER	REEL QTY	RoHS	MSL LEVEL	APPLICATION	TOP MARK	DWG
SSL080860E7A-L-T	1000	YES	3	SPACER	NONE	080860

TopLine®

TITLE NON-CONDUCTIVE SPACER
SSL080860E7A-L-T

SCALE NONE	SIZE A	DRAWING NO. 080860	REV A
---------------	-----------	-----------------------	----------

DO NOT SCALE DRAWING

SHEET 3 OF 5

W8P4 CARRIER TAPE

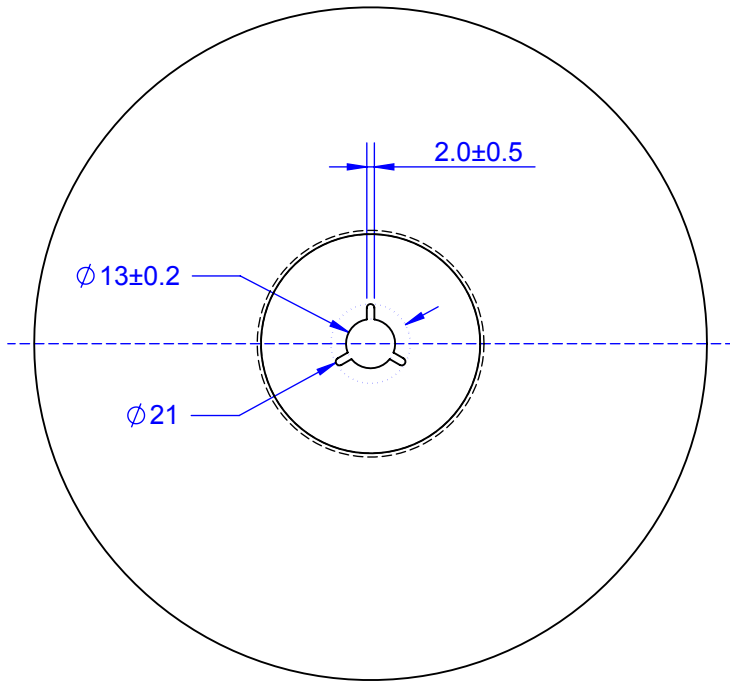
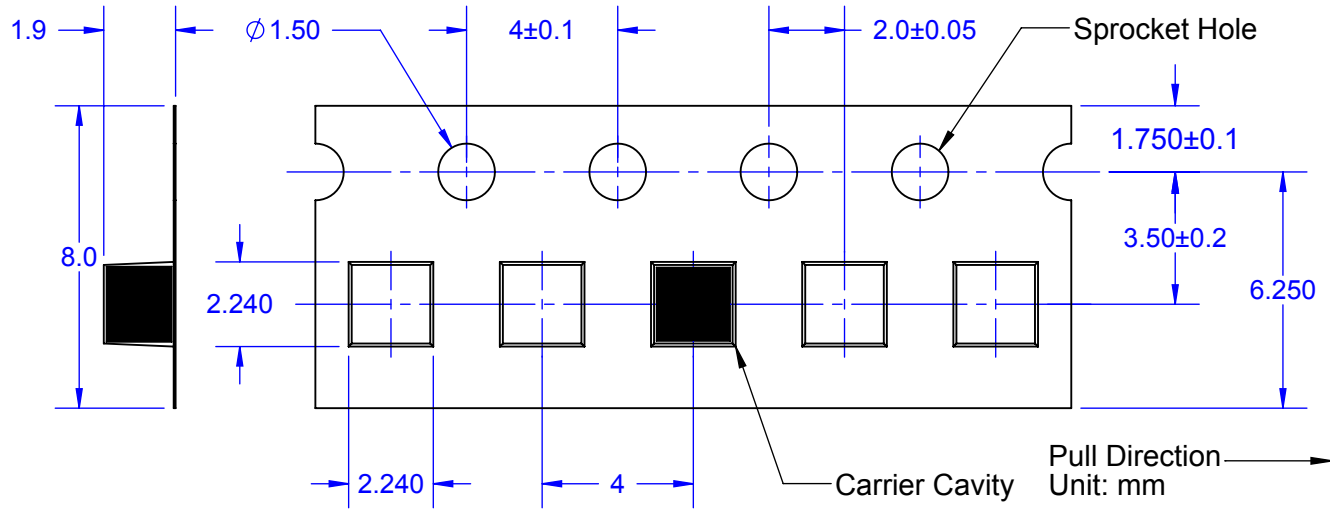

REEL DIMENSIONS

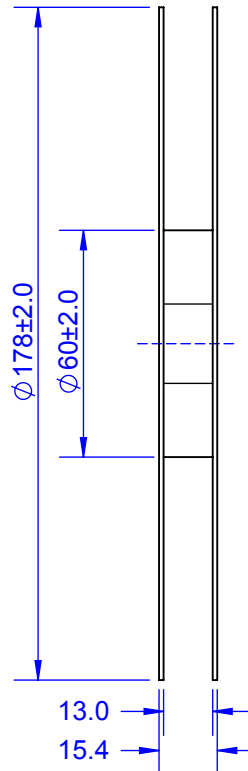

PACK CODE		
CODE	QTY	PACKAGE
E7A	1000	REEL

TopLine[®]

TITLE NON-CONDUCTIVE SPACER
 SSL080860E7A-L-T

SCALE	SIZE	DRAWING NO.	REV
NONE	A	080860	A

DO NOT SCALE DRAWING

SHEET 4 OF 5

LEAD FREE REFLOW PROFILE OF SMD PACKAGE

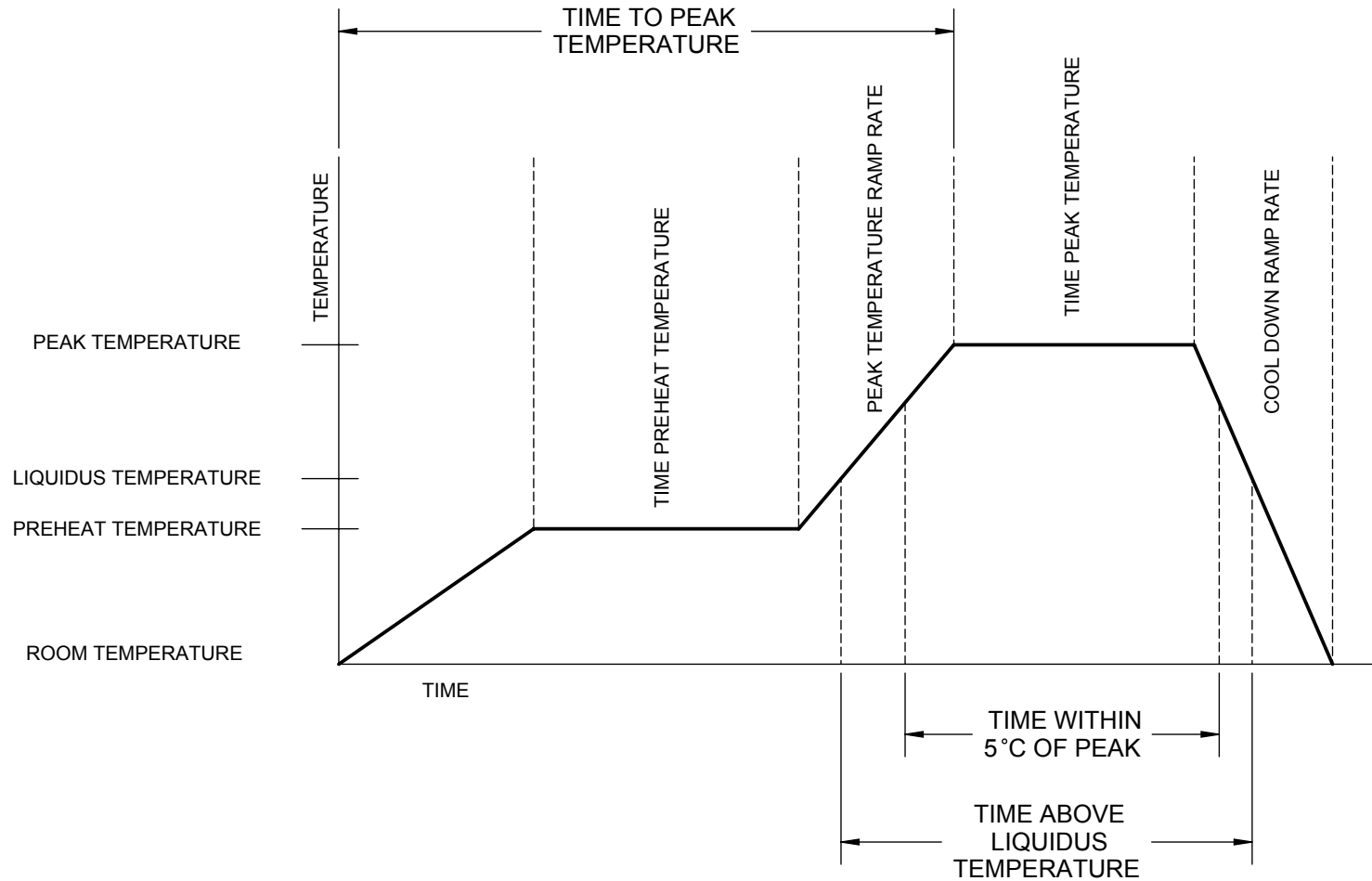

DESCRIPTION	REQUIREMENT
AVERAGE PREHEAT RAMP RATE	3°C /SECOND MAXIMUM
PREHEAT TEMPERATURE	150°C MINIMUM, 200°C MAXIMUM
PREHEAT TIME	60 TO 120 SECONDS
RAMP TO PEAK	3°C /SECOND MAXIMUM
TIME OVER LIQUIDUS (217°C)	60 TO 260 SECONDS
PEAK TEMPERATURE	260°C +0/-5°C
TIME WITHIN 5°C OF PEAK	10 TO 30 SECONDS
RAMP - COOL DOWN	6°C /SECONDS MAXIMUM
TIME 25°C TO PEAK	8 MINUTES MAXIMUM

TopLine®			
TITLE NON-CONDUCTIVE SPACER SSL080860E7A-L-T			
SCALE NONE	SIZE A	DRAWING NO. 080860	REV A
DO NOT SCALE DRAWING			SHEET 5 OF 5