

ÙÒÒ

VUÚ

ÙÒÒ

ÓUVVUT

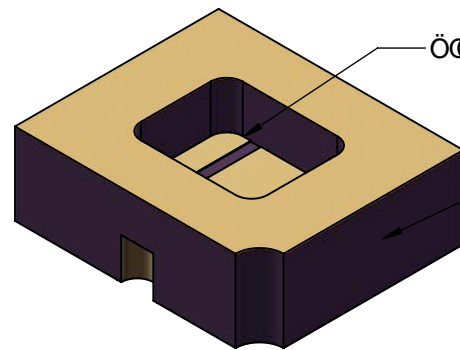
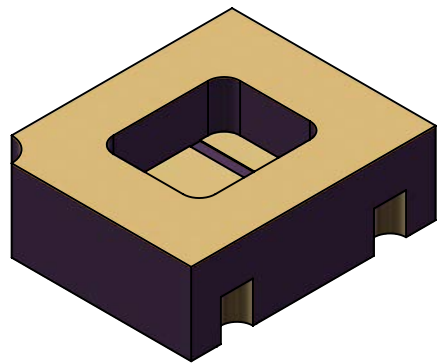
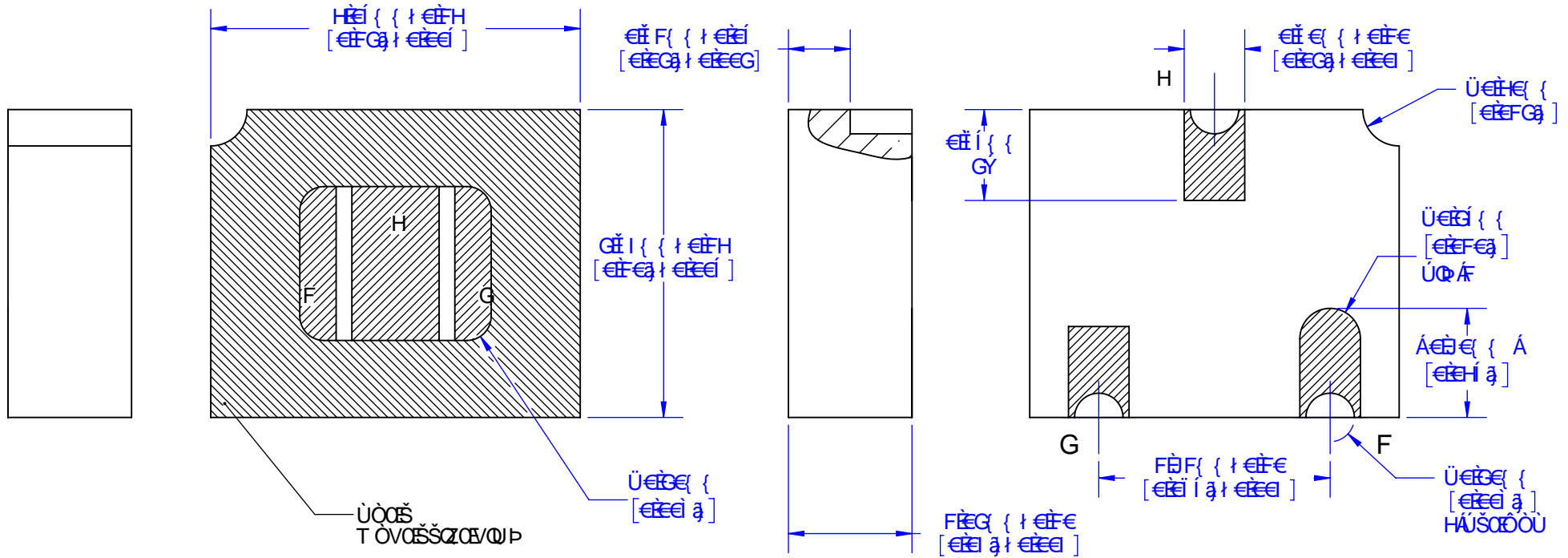

ÖÖ/ÁÖÇXQÿ

ÔÛÖÆ Ô

ΠΙΚ
FÉOUSÁÇE DÚSÖVÁFÉ { Á Ö ÁXÖÚÁÇÉ { Á Ö Á Ö SÖSÉ

αυύυxαsú	öç/ó	TopLine®			
öüçy p VIE	FfEeBGF				
ò-ò T ÈP æc	FfEeBGF	VQ'SÖ ŠÖÖHÉ ÁÖÖÜUVGHÉ PUPÉÜUWPOÖAJÖSÁQÖ			
T ø		úçsö	úçö	öüçy ø ö Æ uÉ	úçx
úçE		GÆF	ÇE	Hfí E-F	ÇE
öwúv					
úçxwöó		öü Æ u V Á ö ç s ö ö ü ç y ø ö			ú ç ö ö v / Æ Á U ç Á

6 CB8 'D5 8 '8-5; F5 A

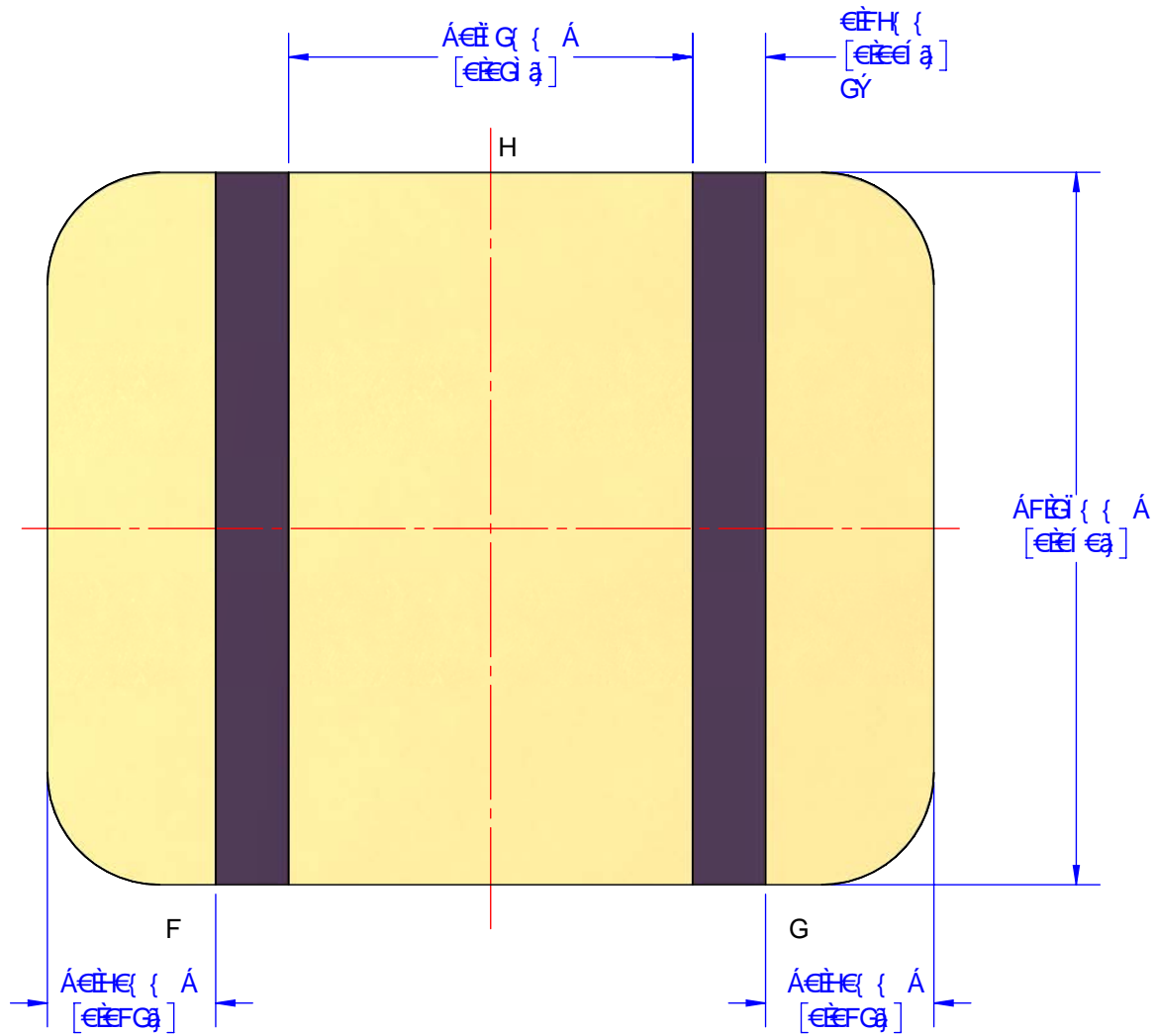

TopLine®			
ΠΡΟΪΟΝΤΑ ΑΥΤΟΜΑΤΩΝ ΚΑΙ ΜΗΧΑΝΩΝ ΠΡΟΪΟΝΤΑ ΑΥΤΟΜΑΤΩΝ ΚΑΙ ΜΗΧΑΝΩΝ			
ΤΙΜΕΣ €	ΤΙΜΕΣ €	ΤΙΜΕΣ €	ΤΙΜΕΣ €
ΟΥΚ ΕΙΝΑΙ ΕΠΙΧΕΙΡΗΣΙΑΚΟ ΠΡΟΪΟΝΤΑ		ΟΥΚ ΕΙΝΑΙ ΕΠΙΧΕΙΡΗΣΙΑΚΟ ΠΡΟΪΟΝΤΑ	

AC89 @G

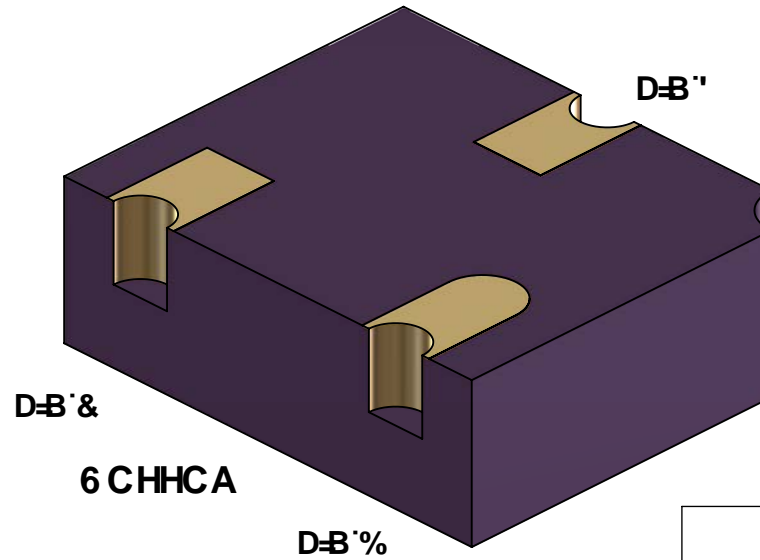
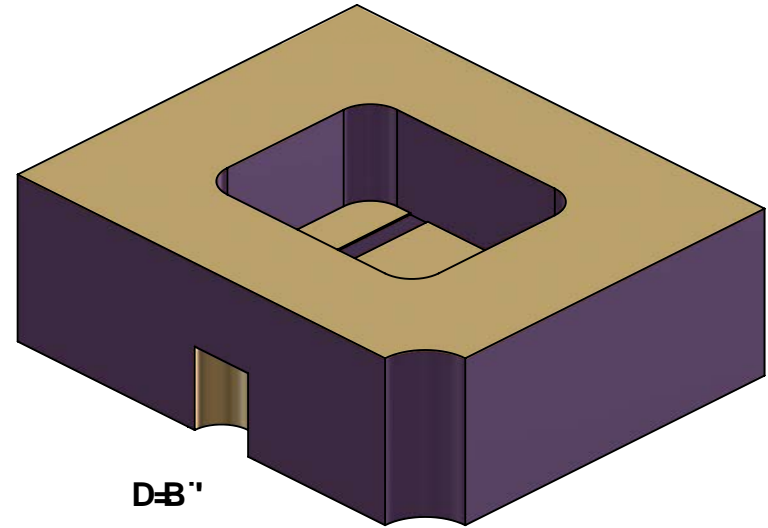
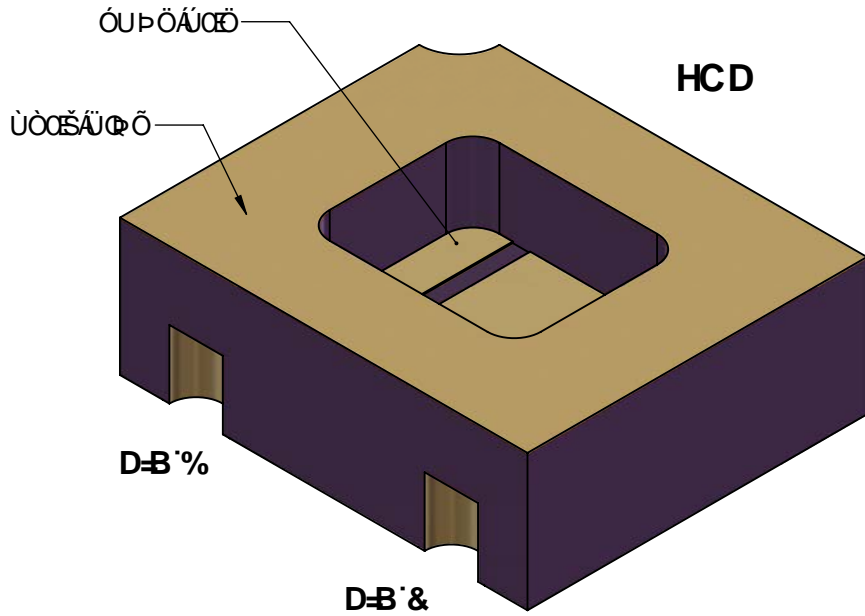

TopLine®			
ναισό ŠÓÔÈ ÆÓÒÙÙUVGÈ ΡΥΡΕÓÙÙWΡÓÓΑΝΟÇŠΑΦÕ			
ÚÒÇŠ Í Í Κ	Úαò Ç	ÓΥΑΥ ΦÕΑΥΕ ΗΓÍ ΕΓ	Úòχ Ç
ÓΥΑΥ VÁÚÓÇŠÓÓÚΑΥ ΦÕ			ÚΡÓÓVÁΗÚÇÁ

D7`6 C5 F8`@5 B8`D5 HH9 FB

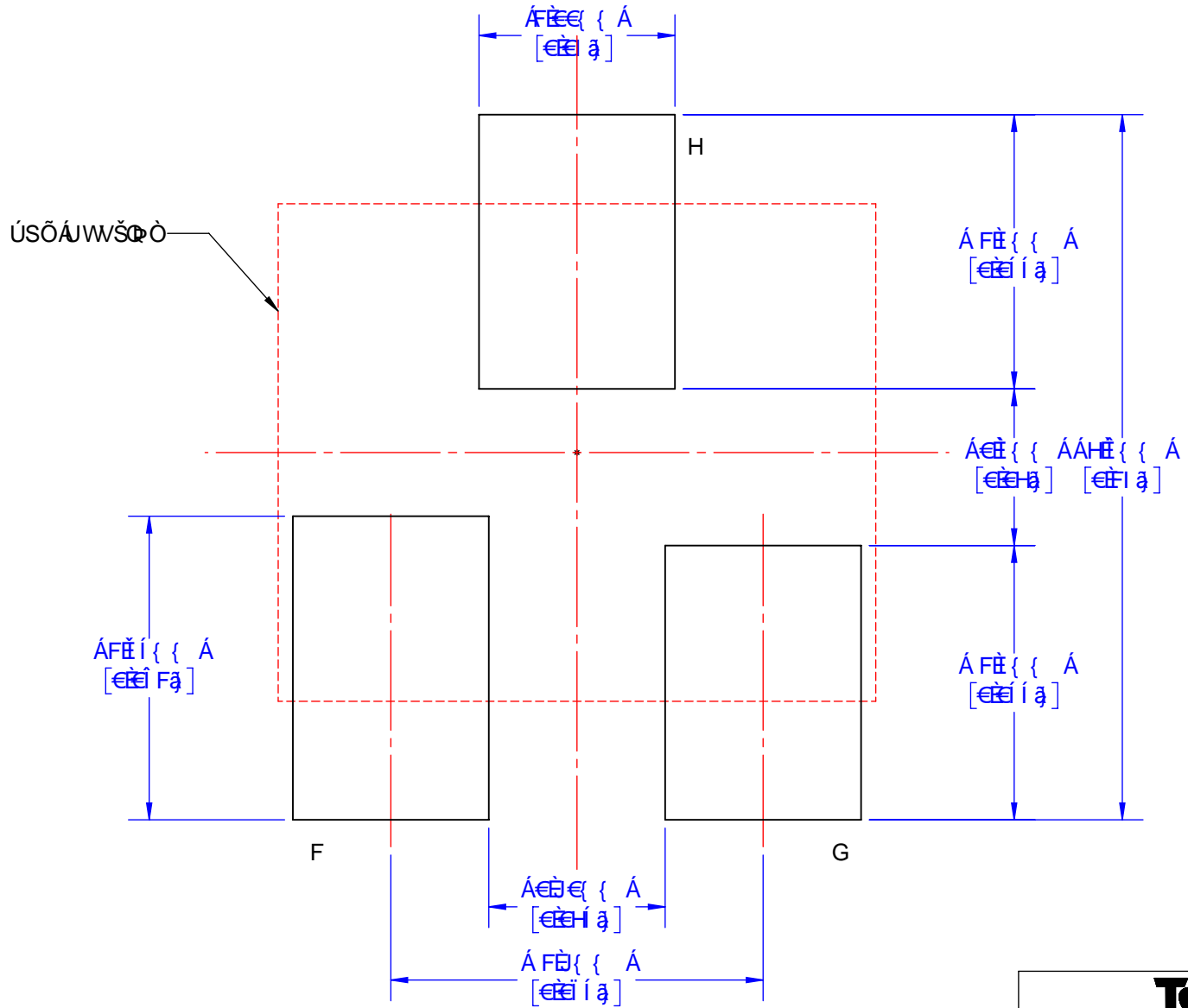

TopLine®			
$\text{V}\text{A}\text{S}\text{O}$ $\text{S}\text{O}\text{O}\text{H}\text{E}\text{A}\text{I}\text{O}\text{O}\text{U}\text{U}\text{V}\text{G}\text{H}\text{E}$ $\text{P}\text{U}\text{P}\text{E}\text{O}\text{U}\text{U}\text{W}\text{P}\text{O}\text{O}\text{A}\text{J}\text{O}\text{O}\text{S}\text{A}\text{J}\text{O}\text{O}$			
$\text{U}\text{O}\text{A}\text{S}\text{O}$ HEF	UAO CE	$\text{O}\text{U}\text{A}\text{Y}\text{O}\text{O}\text{A}\text{U}\text{E}$ HF E-F	UOX CE
$\text{O}\text{U}\text{A}\text{U}\text{V}\text{A}\text{U}\text{O}\text{A}\text{S}\text{O}\text{O}\text{U}\text{A}\text{Y}\text{O}\text{O}$			$\text{U}\text{P}\text{O}\text{O}\text{V}\text{A}\text{A}\text{U}\text{O}\text{A}$

7 CA6 C' @8 fCDH-CB5 @

6 CHCA

G-89

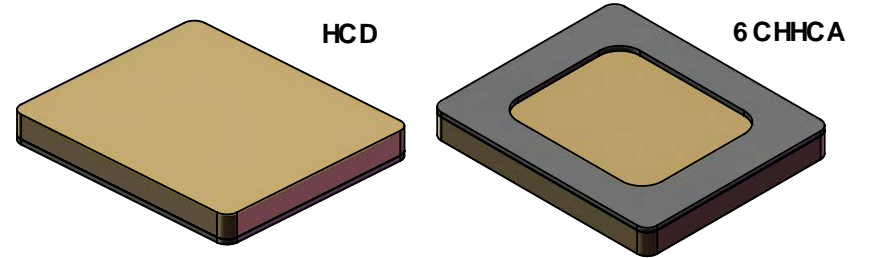
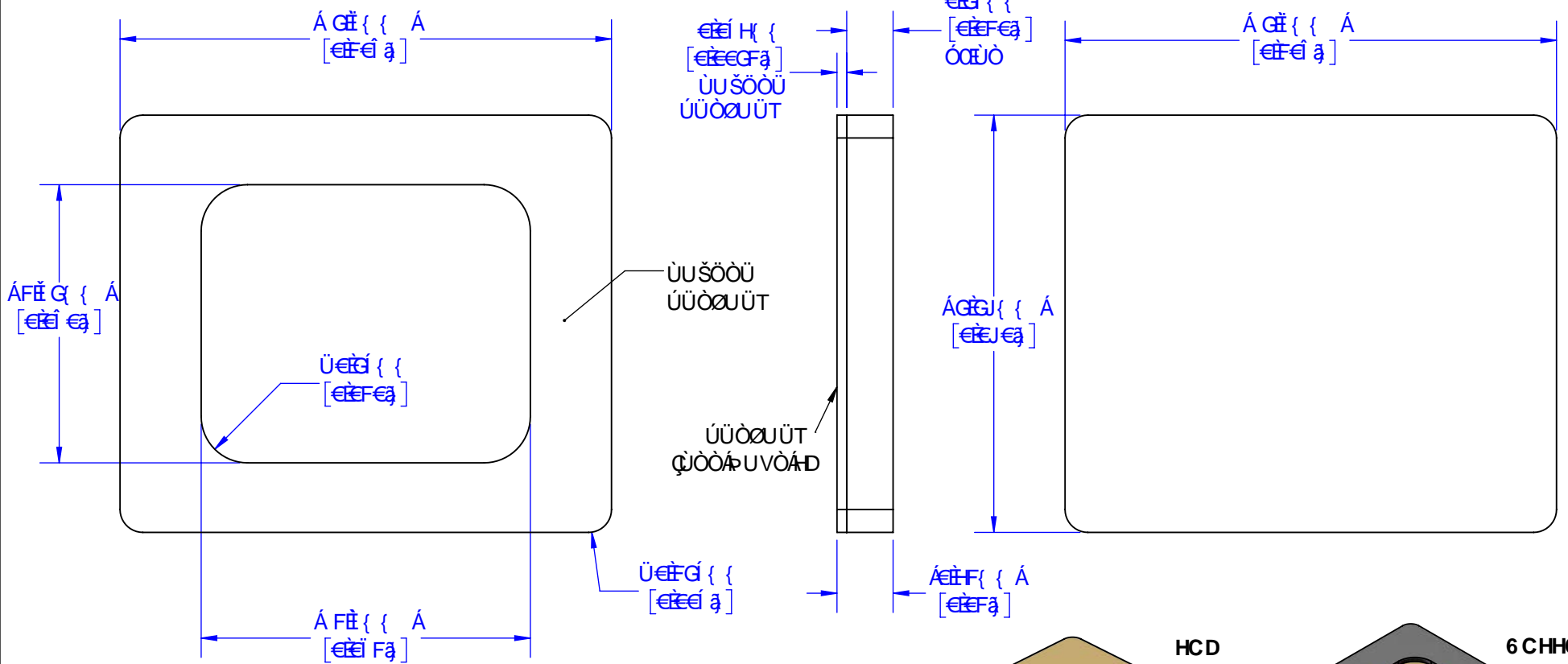

ΠΥΛΟΥΚ
 ΕΠΙΧΕΙΡΗΣΗ ΤΩΝ ΟΡΓΑΝΩΣΕΩΝ ΚΑΙ ΕΠΙΧΕΙΡΗΣΕΩΝ
 ΓΕΩΣΤΡΑΤΗΓΙΚΗΣ ΚΑΙ ΕΠΙΧΕΙΡΗΣΕΩΝ ΟΡΓΑΝΩΣΕΩΝ
 ΚΑΙ ΕΠΙΧΕΙΡΗΣΕΩΝ ΟΡΓΑΝΩΣΕΩΝ
 ΗΜΕΤΕΣ ΟΥΣ ΑΝΤΙΣΤΟΙΧΩΝ ΚΑΙ ΑΝΤΙΣΤΟΙΧΩΝ
 ΙΣΤΟΡΙΑ ΤΩΝ ΟΡΓΑΝΩΣΕΩΝ ΚΑΙ ΕΠΙΧΕΙΡΗΣΕΩΝ

AC89 @

TopLine®			
VARSO		ΟΣΤΕΙΝΕ OUT OUSO	
UOS0 HEF	UZO CE	OUAY O O K UE FHFG I	UX CE
OU KUV AU OASO OUY O O			UP OVA AU ZA

UOZA FG I P