

DIMENSION AND WEIGHT (MASS) TABLE

H HEIGHT ±10%	PCB MASS NOM	TUNGSTEN BALLS IN CAVITY				Est. PID MASS	SCREW ADJUST	SCREW HEX HEAD
		∅ DIA	Per Ball	QTY	MASS			
4.0mm	4.0g	1.5mm	0.031g	13	0.40g	~1.2g	2-56	0.035"

**U.S. PATENTS 10041558,
10021779, 10704639,
10704639, D842351**

NOTES: (Unless Otherwise Specified).

1. DIMENSIONS: mm.

2. MOUNTING: Glue or Adhesive.

3. Alternative mounting screws. See DWG 129401

APPROVALS	DATE	TopLine®			
DRAWN T. Au	5/31/2023	TITLE FA0.4SQ10x4.0A PID VIBRATION DAMPER			
ENG M. Hart	5/31/2023				
MFG		SCALE 1:1	SIZE A	DRAWING NO. 139401	REV A
QA		DO NOT SCALE DRAWING		SHEET 1 OF 3	
CUST					
REVISED					

MODEL

TOP

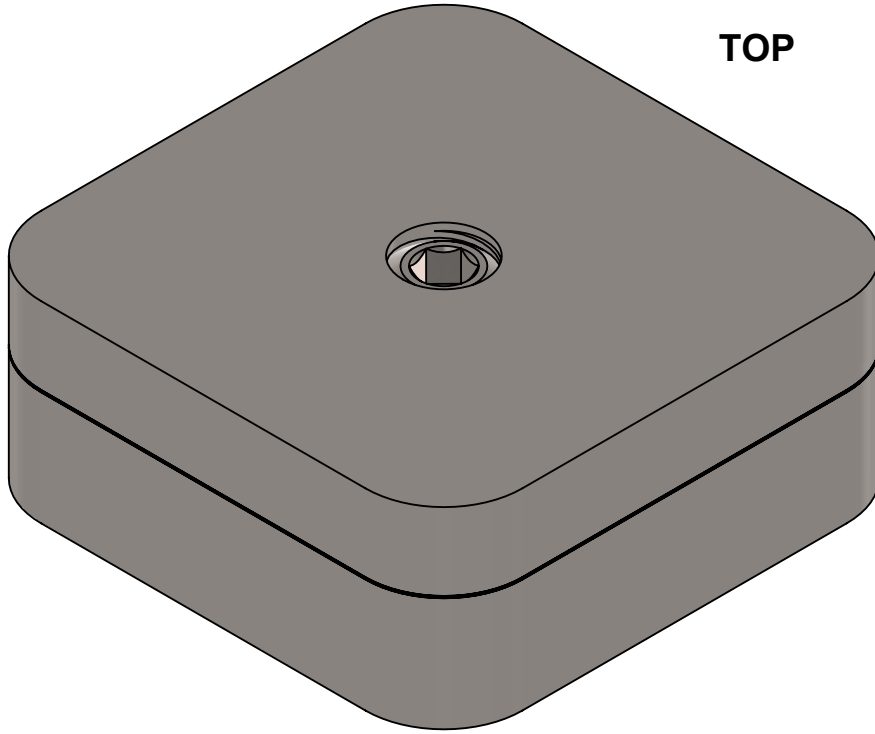

BOTTOM

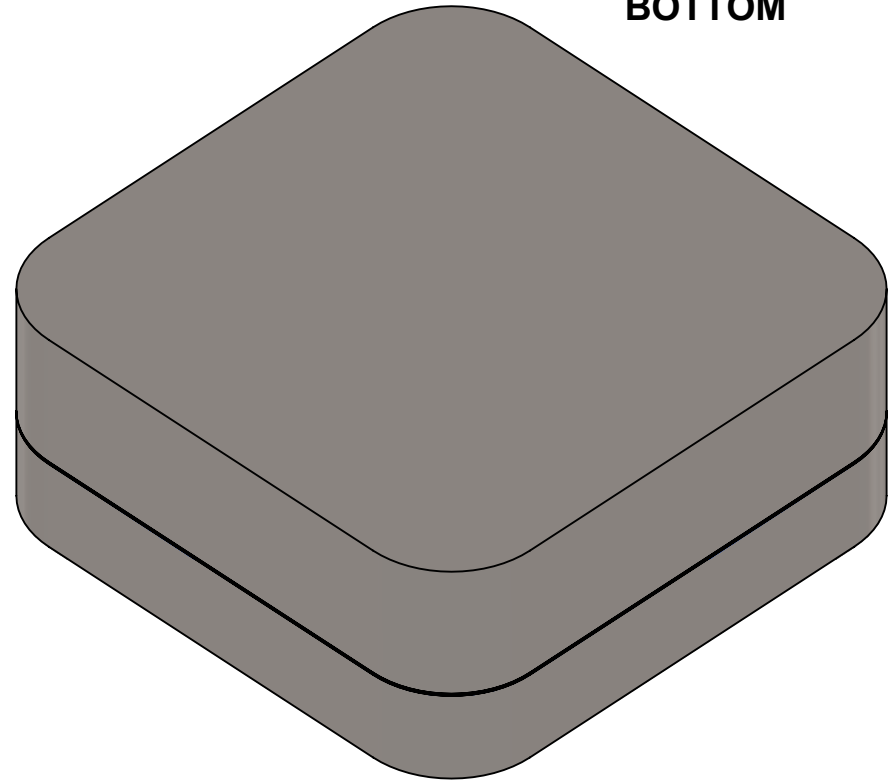

NOTES:

1. CONTACT TOPLINE FOR OTHER MOUNTING OPTIONS.

TopLine®

TITLE FA0.4SQ10x4.0A
PID VIBRATION DAMPER

SCALE 3:2	SIZE A	DRAWING NO. 139401	REV A
--------------	-----------	-----------------------	----------

DO NOT SCALE DRAWING

SHEET 2 OF 3

<u>F</u>	<u>A</u>	<u>0.4</u>	<u>SQ</u>	<u>10x</u>	<u>4.0</u>	<u>A</u>
Series	Mounting on PCB	Tungsten Payload Grams	Exterior Shape	XY Size	Height	Version/Option
Filled	Mounting Style	Code Grams	Code Shape	Code Size	Code Height	Code Version
F = FR4	A = ADHESIVE GLUE S = SCREW MOUNT	0.4 = 0.4gm Other Mass Available	SQ Square R Rectangle C Cylindrical T Toroid Z Custom	10X = 10mm SQ Other Sizes Available	4.0 = 4.0mm Other Sizes Available	A = STANDARD Other Version Available

Order Number

<u>1</u>	<u>3</u>	<u>940</u>	<u>1</u>
DESCRIPTION	Mount Style	Mass (gm) 9 = Decimal	Option Code
<u>Code</u> <u>Description</u>	<u>Code</u> <u>Description</u>	<u>Code</u> <u>MASS</u>	<u>Code</u> <u>Option</u>
1 = Filled PID	2 = Screw 3 = Adhesive 9 = Custom 0 = Master DWG	940 = 0.4 gm	1 = VERSION A

TopLine®

TITLE FA0.4SQ10x4.0A
PID VIBRATION DAMPER

SCALE NONE	SIZE A	DRAWING NO. 139401	REV A
---------------	-----------	-----------------------	----------

DO NOT SCALE DRAWING

SHEET 3 OF 3