

**STREETS AND AVENUES
INDEX FROM FIDUCIALS**

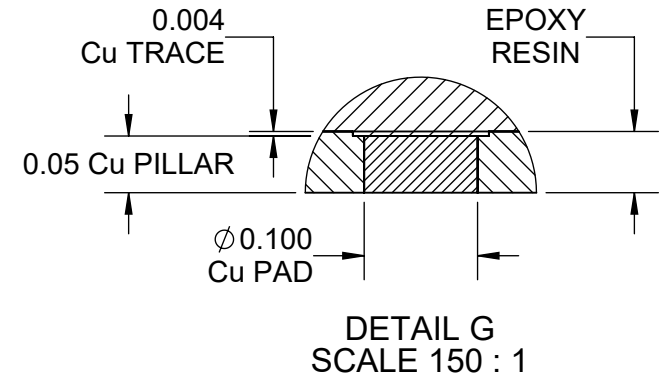
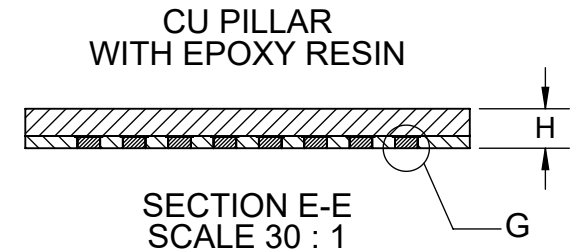
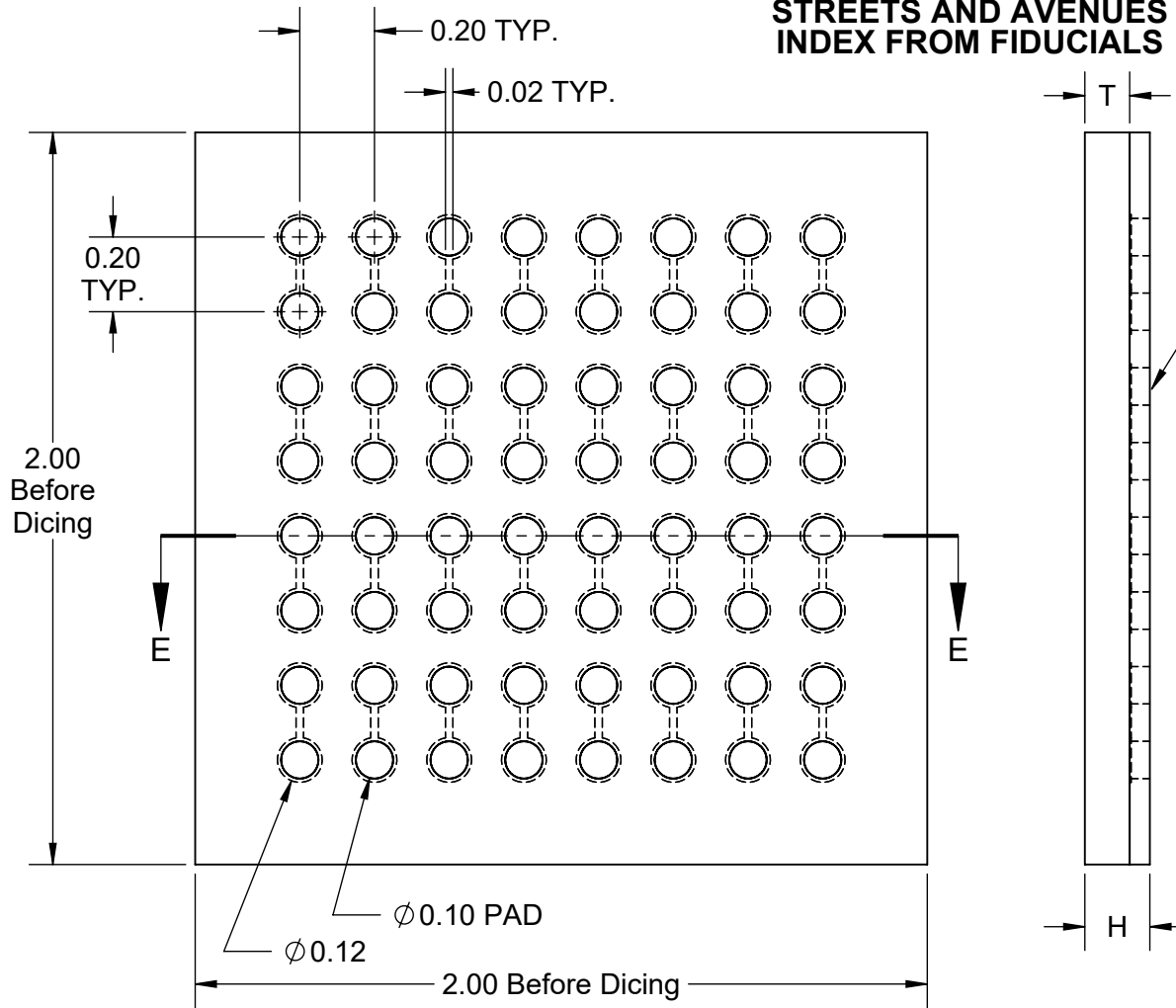

DIE THICKNESS OPTIONS		
CODE	THICKNESS Si DIE (T)	TOTAL THICKNESS WITHOUT BUMPS (H)
2	0.230mm	0.280mm
3	0.310mm	0.360mm
4	0.360mm	0.410mm
6	0.620mm	0.670mm

NOTES:
1. DIMENSIONS MM UNLESS OTHERWISE STATED.

TopLine®			
TITLE eWLP3136T.2-DC567D DAISY CHAIN COPPER PAD DIE			
SCALE 50:1	SIZE A	DRAWING NO. 625670	REV A
DO NOT SCALE DRAWING			SHEET 2 OF 4

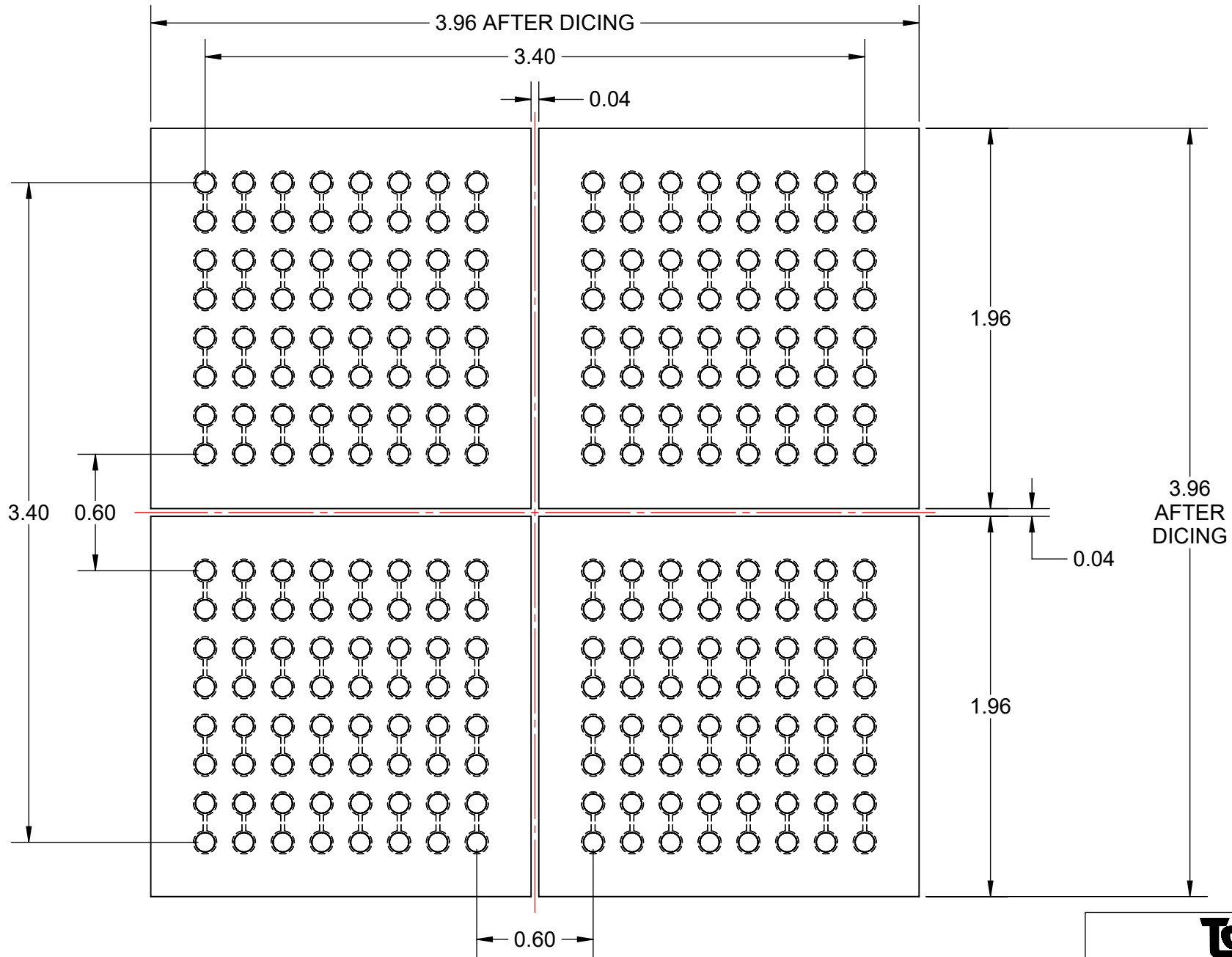

1. DIMENSIONS MM.

TopLine®

TITLE eWLP3136T.2-DC567D
DAISY CHAIN COPPER PAD DIE

SCALE 35:1	SIZE A	DRAWING NO. 625670	REV A
---------------	-----------	-----------------------	----------

DO NOT SCALE DRAWING

SHEET 3 OF 4

PART NUMBERING SYSTEM

eWLP

3136

SERIES

eWLP = COPPER PADS WITHOUT BUMPS

NUMBER OF PADS

PADS	SIZE
64	2.0x2.0mm
256	4.0x4.0mm
576	6.0x6.0mm
1024	8.0x8.0mm
1600	10x10mm
2304	12x12mm
3136	14x14mm
4096	16x16mm
999	Full Wafer

T

.2

-

DC567

D

2



.2 = 0.2mm
200µm



PAD PITCH

DAISY CHAIN DRAWING

PACKAGING

CODE	PACKAGE
W	2" TRAY
T	4" TRAY
E	TAPE & REEL
U	UV TAPE & RING
X	UNSAWN WAFER

DIE THICKNESS

CODE	THICKNESS
2	200µm
3	360µm
6	670µm

PADS FACE UP/DOWN

D = COPPER PADS DOWN
U = COPPER PADS UP



TITLE eWLP3136T.2-DC567D
DAISY CHAIN COPPER PAD DIE

SCALE	SIZE	DRAWING NO.	REV
NONE	A	625670	A

DO NOT SCALE DRAWING

SHEET 4 OF 4