

### TOP VIEW

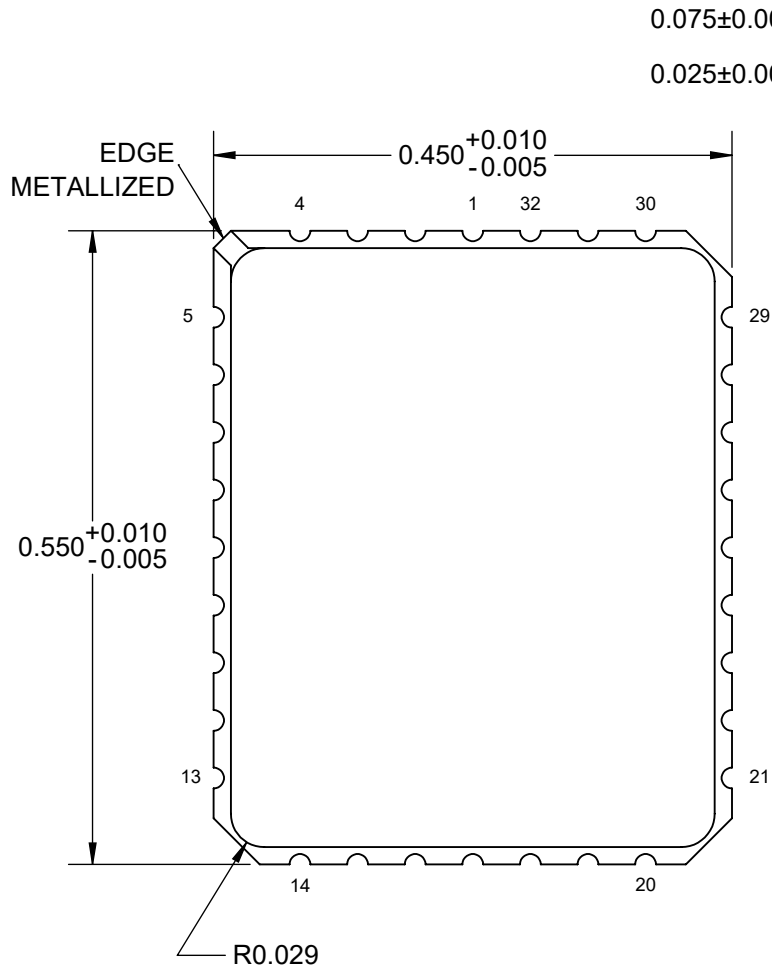

### SIDE VIEW

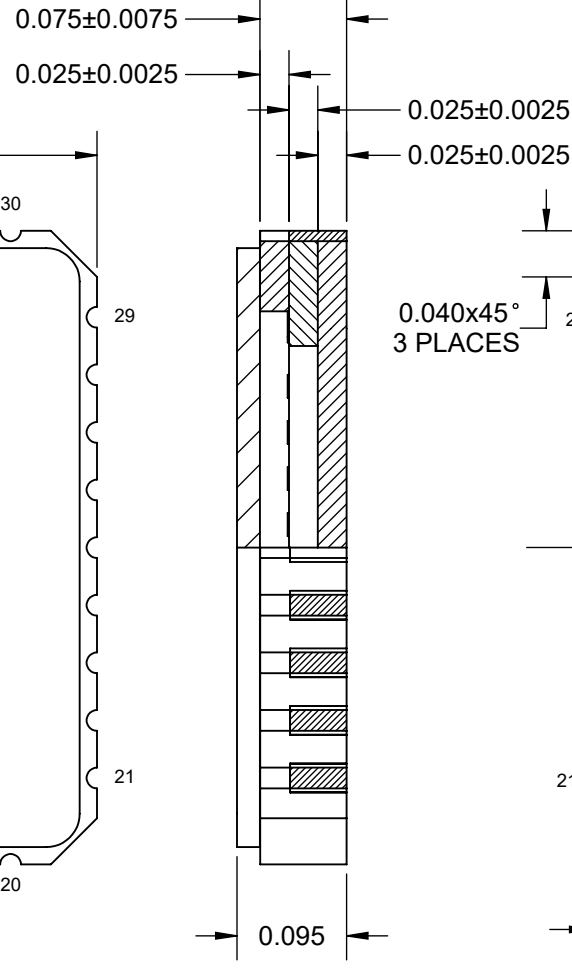

### BOTTOM VIEW

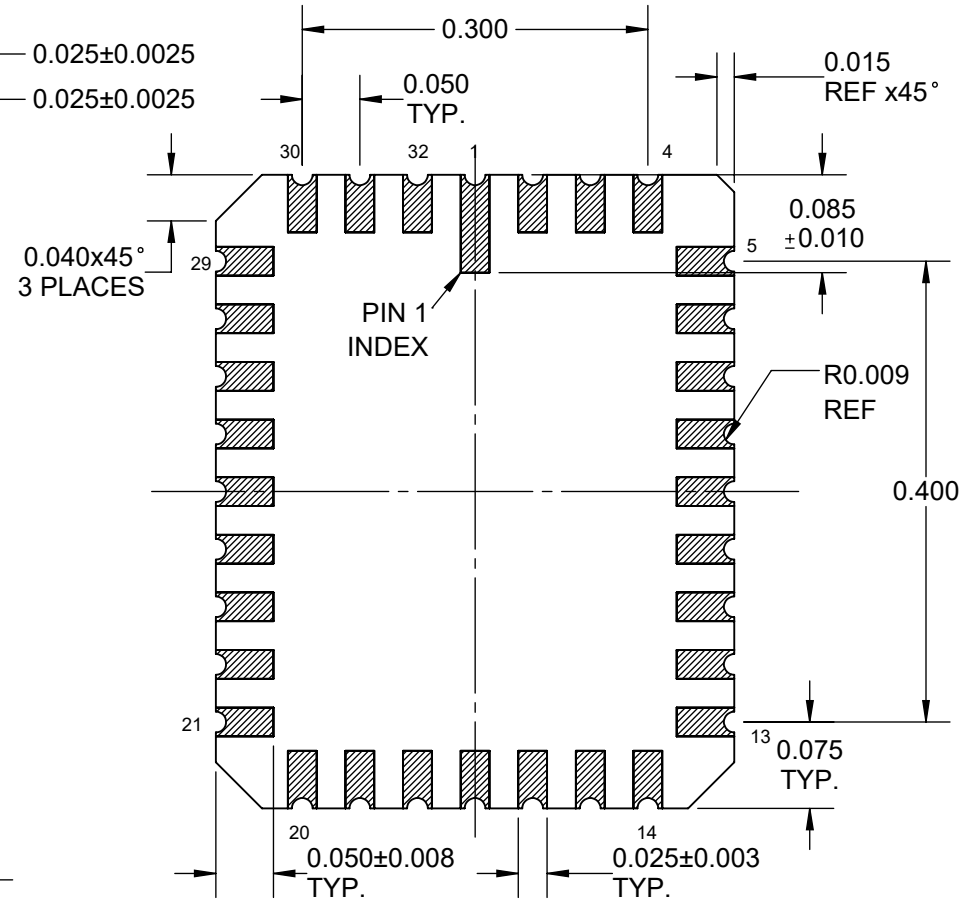

NOTES: (Unless Otherwise Specified).

1) PLATING:

Ni 80 Micro-inch (2.0µm) MIN.

Au60 Micro-inch (1.5µm) MIN.

2) DIMENSIONS IN INCH (Unless Specified).

PART NUMBER	COVER	PLATING	DAISY CHAIN
LCC32B50SQ.45X.55-N	OPEN	NiAu	NO
LCC32B50SQ.45X.55	SEALED	NiAu	NO
LCC32B50SQ.45X.55-SC	SEALED	SnPb	NO
LCC32B50SQ.45X.55-DE	SEALED	NiAu	YES
LCC32B50R.45X.55-DE-SC	SEALED	SnPb	YES

APPROVALS	DATE				
DRAWN T. Au	11/21/2019				
ENG M. Hart	11/21/2019	TITLE LCC32B50R.45x.55			
MFG		SCALE 6:1	SIZE A	DRAWING NO. 143201	REV A
QA					
CUST					
REVISED		DO NOT SCALE DRAWING			SHEET 1 OF 3

# LCC32B50SQ.45x.55-DE DAISY CHAIN

## TOP VIEW

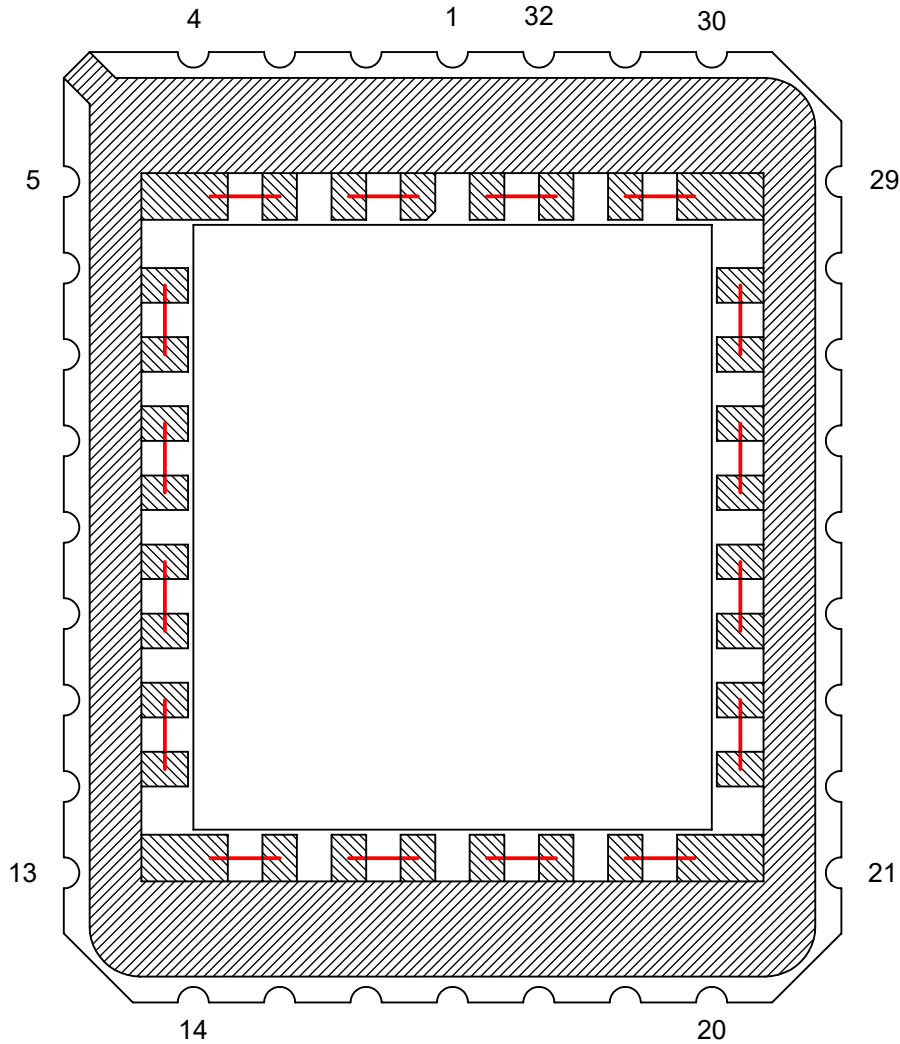

## BOTTOM VIEW

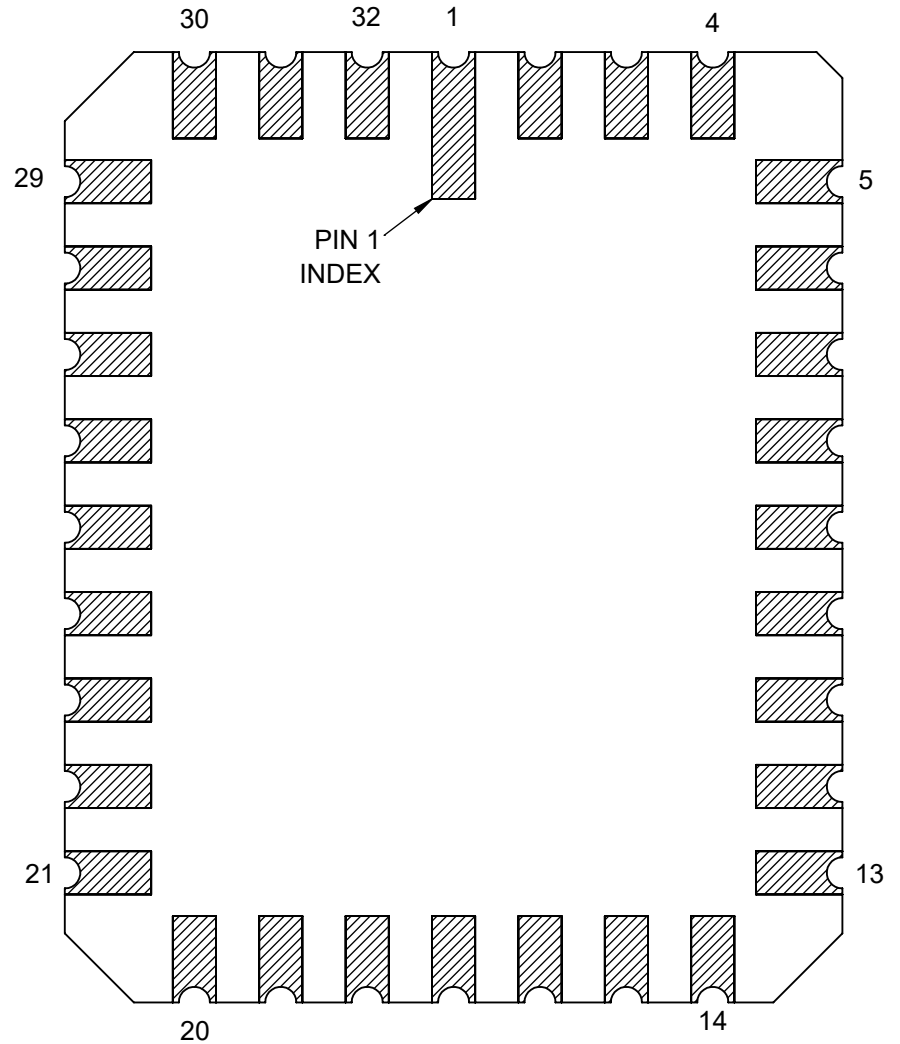

### DAISY CHAIN NET LIST

FROM / TO	FROM / TO	FROM / TO	FROM / TO
1 ~ 2	9 ~ 10	17 ~ 18	25 ~ 26
3 ~ 4	11 ~ 12	19 ~ 20	27 ~ 28
5 ~ 6	13 ~ 14	21 ~ 22	29 ~ 30
7 ~ 8	15 ~ 16	23 ~ 24	31 ~ 32

**TopLine®**

TITLE  
LCC32B50R.45X.55

SCALE 9:1	SIZE A	DRAWING NO. 143201	REV A
--------------	-----------	-----------------------	----------

DO NOT SCALE DRAWING

SHEET 2 OF 3

# MODEL

TOP

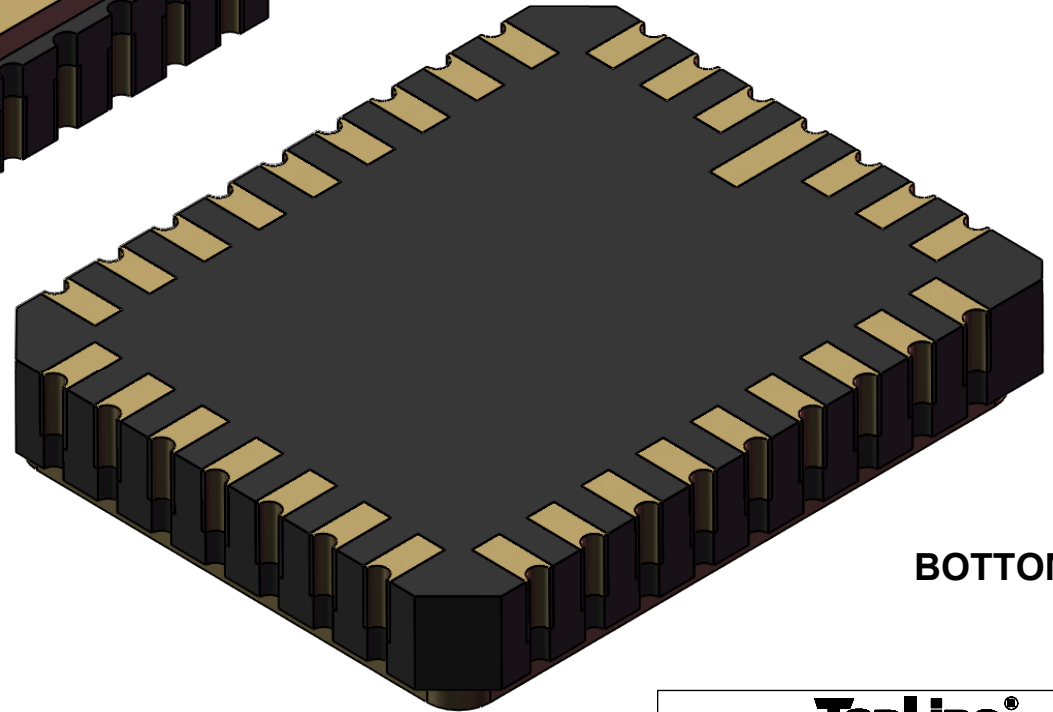
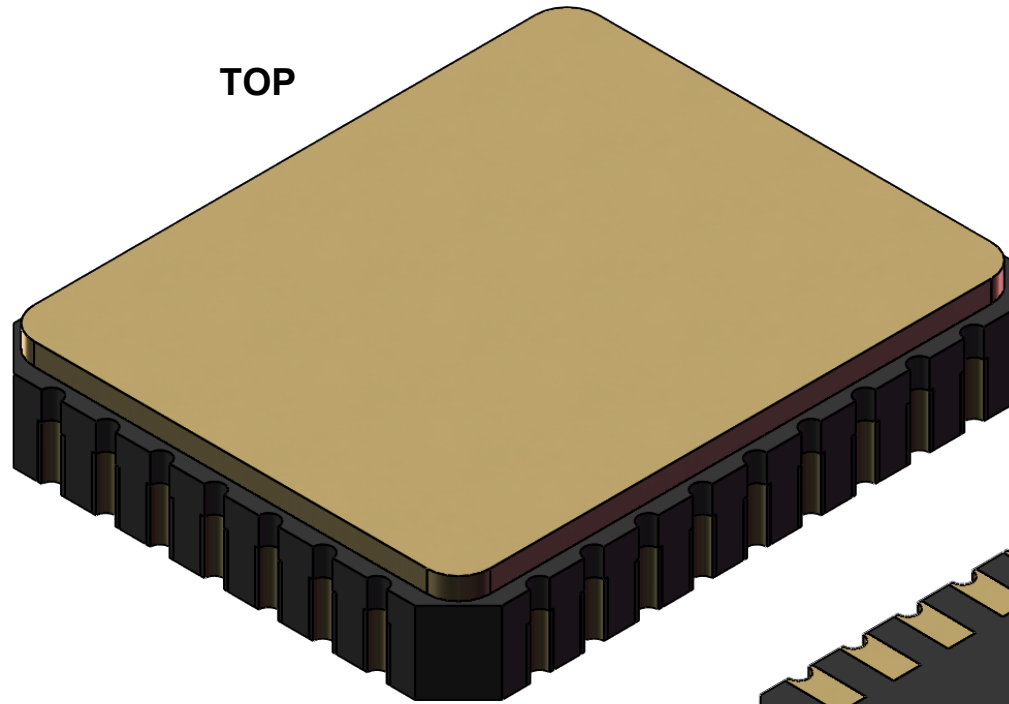

BOTTOM

**TopLine**<sup>®</sup>

TITLE LCC32B50R.45X.55

SCALE 8:1	SIZE A	DRAWING NO. 143201	REV A
--------------	-----------	-----------------------	----------

DO NOT SCALE DRAWING SHEET 3 OF 3