



Custom PCB Spacer Questionnaire



Tel: 1-800-776-9888
Email: info@TopLine.tv

Date _____ 20____

Position Engineering Purchasing

Contact _____ Title _____

Company _____ Tel _____ Ext _____

email _____ Project Ref# _____

Mounting on PCB Solder Glue/Adhesive Mount Other _____

Size Code: 0201 0402 0603 0805 1206 Other _____

Spacer Height (H) : _____ mm Inch Height Tolerance ±10% Other _____

Spacer Length (L) : _____ mm Inch Spacer Width (W) : _____ mm Inch

PCB Dimension mm Inch A _____ B _____ C _____ D _____ E _____ F _____

Purpose: Adjacent boards Hold up shield Support heavy part Other _____

Application: _____ PCB Material

_____ FR4

_____ Other

Quantity: Estimated Annual Usage _____ pcs One-time buy only _____ pcs

Delivery: Samples needed by _____ Mass production starts _____

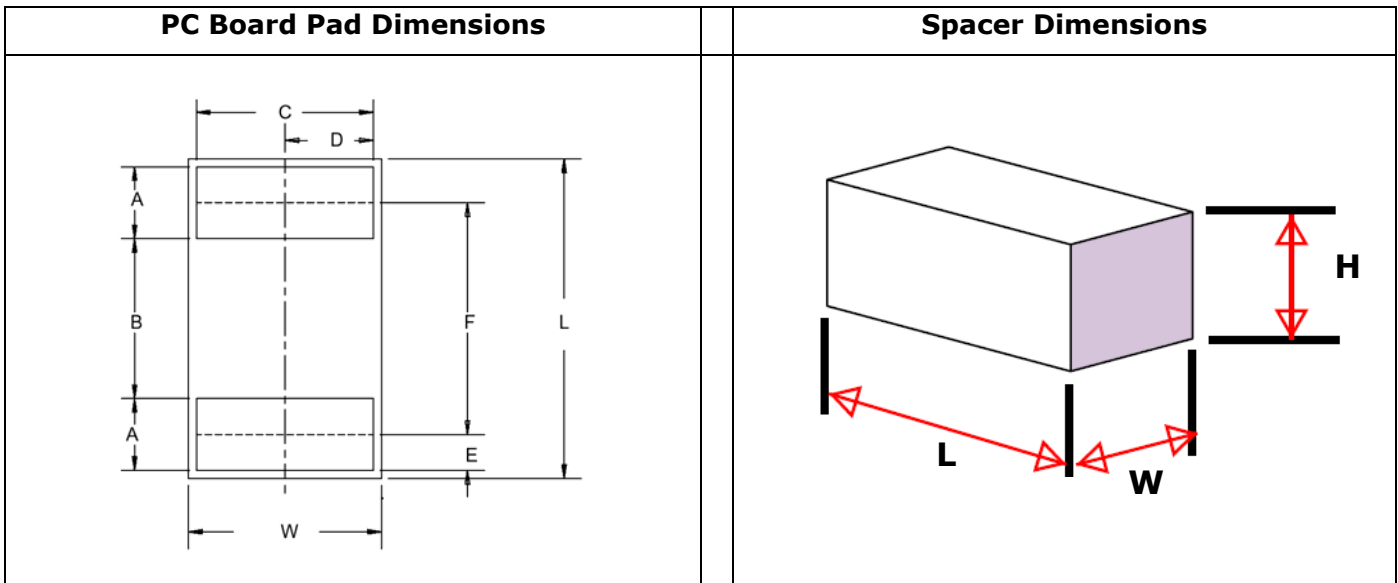

Return this questionnaire to info@TopLine.tv