

TOP VIEW

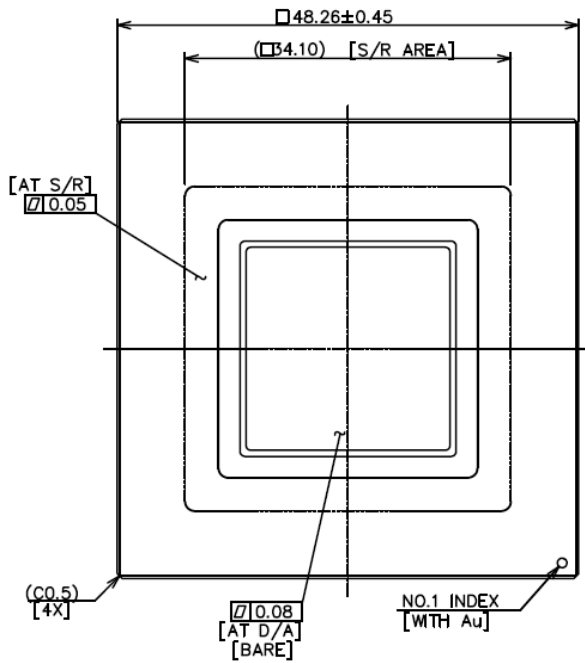

DIE PAD
0.840" x 0.840"
21.24 x 21.24mm

SIDE VIEW

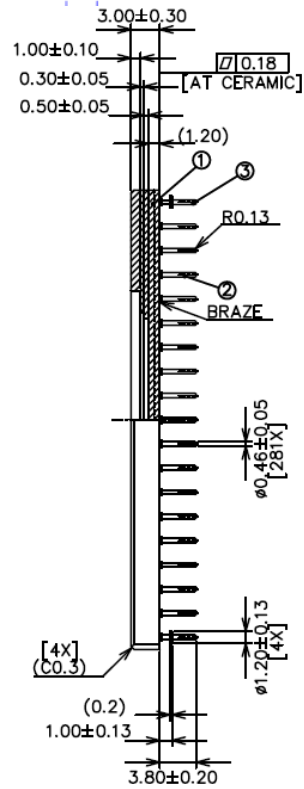

BOTTOM VIEW

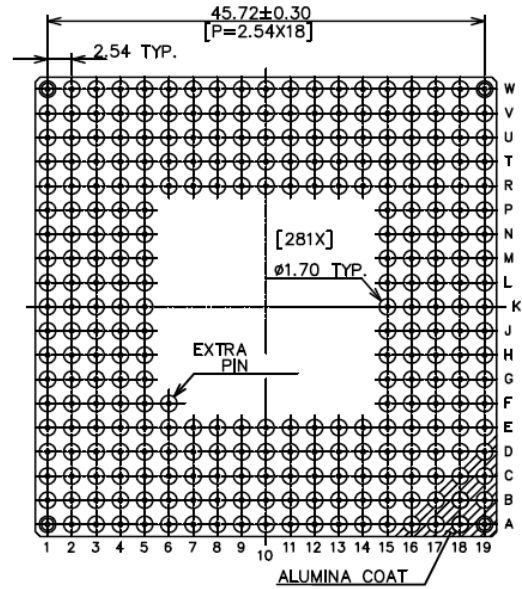

NOTES: (Unless Otherwise Specified).

1. DIMENSIONS IN inches.
2. ALL EXPOSED METAL AND METALLIZED AREA SHALL BE GOLD PLATED. 60 MICRO INCH MIN. THICKNESS. OVER NICKEL PLATED.
3. SEAL AREA AND DIE ATTACH AREA SHALL BE ISOLATED.

APPROVALS	DATE	TopLine®			
DRAWN	ENG M. Hart	07/07/17	TITLE CPGA281T19x19-N840		
MFG	QA	SCALE	SIZE	DRAWING NO.	REV
CUST		2.5:1	A	182187	A
REVISED	DO NOT SCALE DRAWING			SHEET 1 OF 4	

BOND PAD

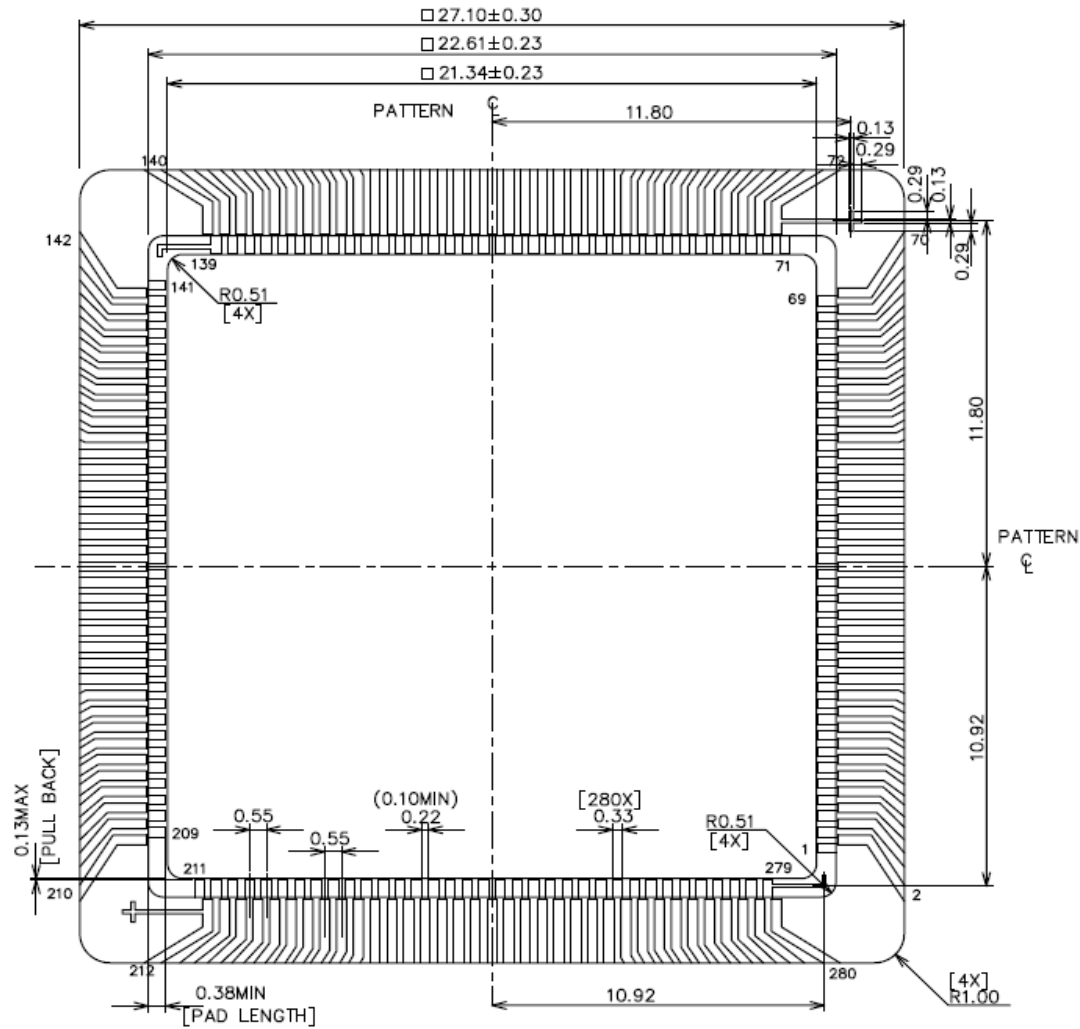

TopLine[®]

TITL **CPGA281T19x19-N840**

SCALE	SIZE	DRAWING NO.	REV
10:1	A	182187	A

DO NOT SCALE DRAWING

SHEET 2 OF 4

BOND PAD NET LIST

W/B NO.	PIN NO.
1	E5
2	C3
3	D4
4	B2
5	F5
6	B1
7	A1
8	C2
9	E4
10	C1
11	G5
12	D2
13	D3
14	D1
15	F4
16	E2
17	E3
18	E1
19	H5
20	F2
21	G4
22	F1
23	F3
24	G2
25	H4
26	G1
27	J5
28	H2
29	G3
30	H1
31	H3
32	J2
33	J4
34	J1
35	J3
36	K2
37	K5
38	K1
39	K4
40	L1
41	K3
42	L2
43	L3
44	M1
45	L5
46	M2
47	L4
48	N1
49	M3
50	N2

W/B NO.	PIN NO.
51	M4
52	P1
53	M5
54	P2
55	N3
56	R1
57	N4
58	T1
59	P3
60	R2
61	N5
62	U1
63	P4
64	T2
65	R3
66	V1
67	R4
68	T3
69	P5
70	U2
71	R5
72	U3
73	T4
74	V2
75	R6
76	W2
77	W1
78	V3
79	T5
80	W3
81	R7
82	V4
83	U4
84	W4
85	T6
86	V5
87	U5
88	W5
89	R8
90	V6
91	T7
92	W6
93	U6
94	V7
95	T8
96	W7
97	R9
98	V8
99	U7
100	W8

W/B NO.	PIN NO.
101	U8
102	V9
103	T9
104	W9
105	U9
106	V10
107	R10
108	W10
109	T10
110	W11
111	U10
112	V11
113	U11
114	W12
115	R11
116	V12
117	T11
118	W13
119	U12
120	V13
121	T12
122	W14
123	R12
124	V14
125	U13
126	W15
127	T13
128	W16
129	U14
130	V15
131	R13
132	W17
133	T14
134	V16
135	U15
136	W18
137	T15
138	U16
139	R14
140	V17
141	R15
142	U17
143	T16
144	V18
145	P15
146	V19
147	W19
148	U18
149	R16
150	U19

W/B NO.	PIN NO.
151	N15
152	T18
153	T17
154	T19
155	P16
156	R18
157	R17
158	R19
159	M15
160	P18
161	N16
162	P19
163	P17
164	N18
165	M16
166	N19
167	L15
168	M18
169	N17
170	M19
171	M17
172	L18
173	L16
174	L19
175	L17
176	K18
177	K15
178	K19
179	K16
180	J19
181	K17
182	J18
183	J17
184	H19
185	J15
186	H18
187	J16
188	G19
189	H17
190	G18
191	H16
192	F19
193	H15
194	F18
195	G17
196	E19
197	G16
198	D19
199	F17
200	E18

W/B NO.	PIN NO.
201	G15
202	C19
203	F16
204	D18
205	E17
206	B19
207	E16
208	D17
209	F15
210	C18
211	E15
212	C17
213	D16
214	B18
215	E14
216	A18
217	A19
218	B17
219	D15
220	A17
221	E13
222	B16
223	C16
224	A16
225	D14
226	B15
227	C15
228	A15
229	E12
230	B14
231	D13
232	A14
233	C14
234	B13
235	D12
236	A13
237	E11
238	B12
239	C13
240	A12
241	C12
242	B11
243	D11
244	A11
245	C11
246	B10
247	E10
248	A10
249	D10
250	A9

W/B NO.	PIN NO.
251	C10
252	B9
253	C9
254	A8
255	E9
256	B8
257	D9
258	A7
259	C8
260	B7
261	D8
262	A6
263	E8
264	B6
265	C7
266	A5
267	D7
268	A4
269	C6
270	B5
271	E7
272	A3
273	D6
274	B4
275	C5
276	A2
277	D5
278	C4
279	E6
280	B3

TopLine[®]

TITLE **CPGA281T19x19-N840**

SCALE NONE	SIZE A	DRAWING NO. 182187	REV A
---------------	-----------	------------------------------	----------

DO NOT SCALE DRAWING

SHEET 3 OF 4

STACK UP

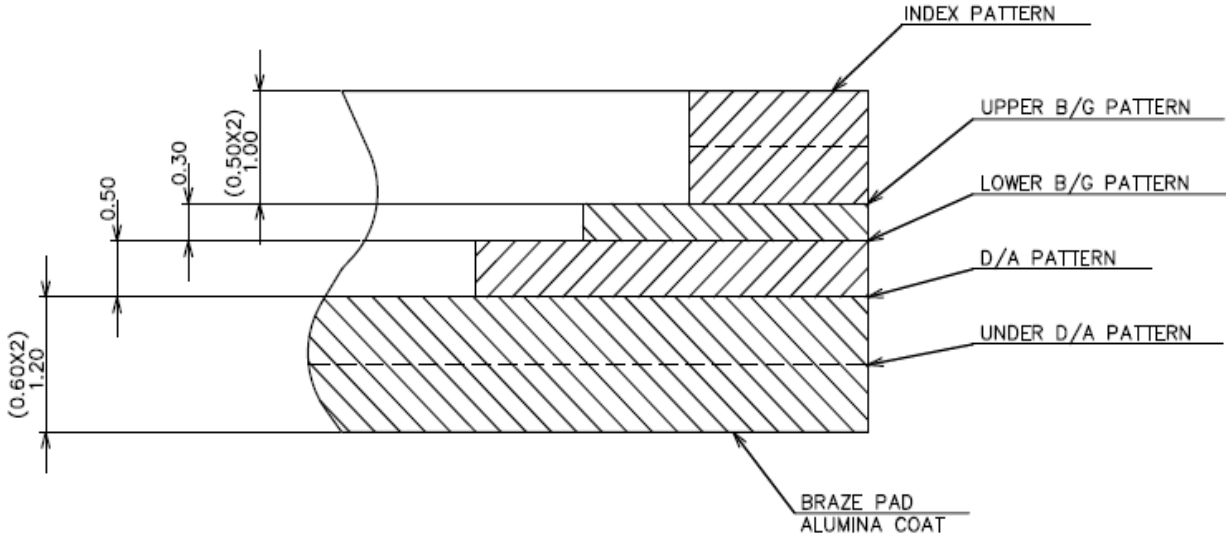

TopLine®			
TITLE CPGA281T19x19-N840			
SCALE	SIZE	DRAWING NO.	REV.
4:1	A	182187	A
DO NOT SCALE DRAWING			SHEET 4 OF 4