

## TOP VIEW

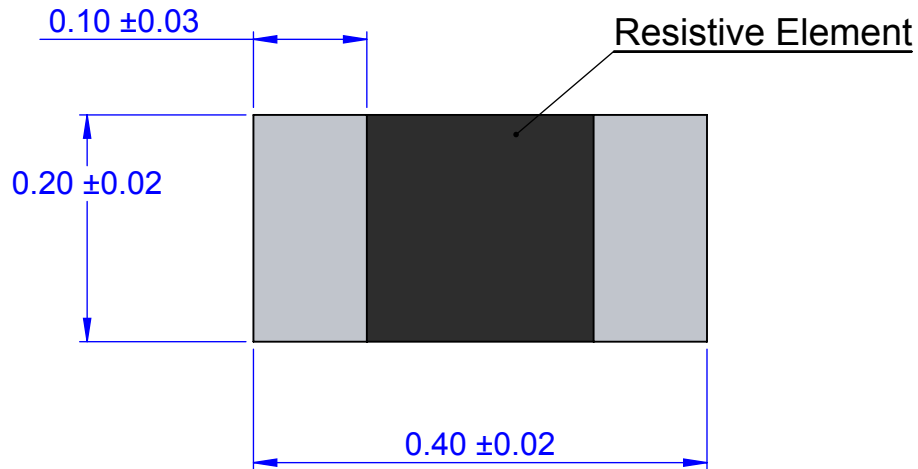

## RECOMMENDED PCB PATTERN

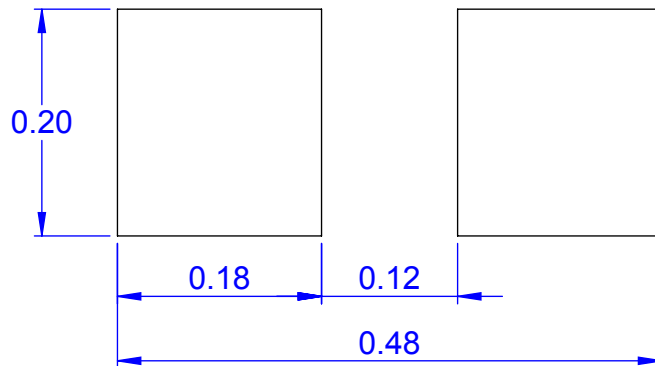

PCB DIMENSIONS ARE PRESENTED ONLY AS A GUIDELINE.  
DESIGNERS SHOULD USE THEIR OWN KNOWLEDGE BASE WHEN  
DESIGNING THE PCB.

## STRUCTURE

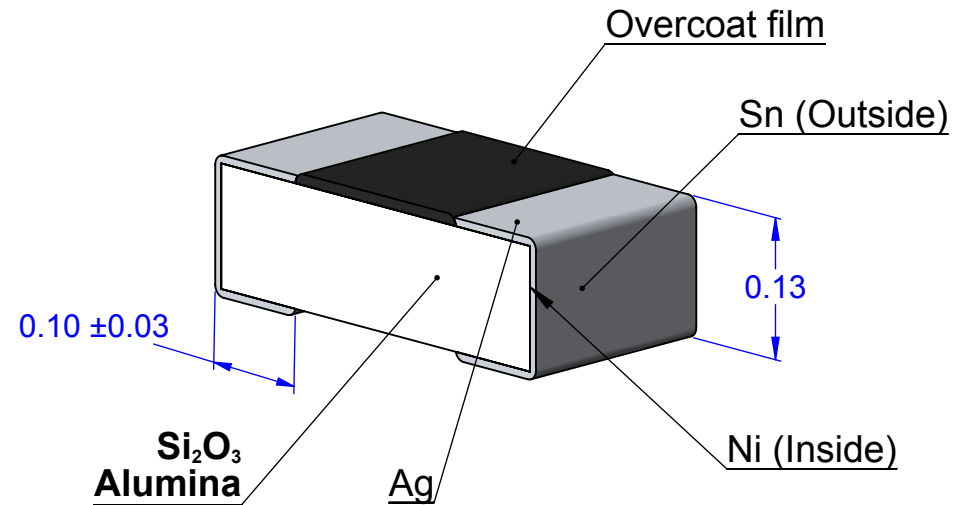

## NOTES:

1. DIMENSIONS IN mm.
2. TERMINATION: Tin (Sn).
3. Pb-FREE AND HALOGEN FREE.

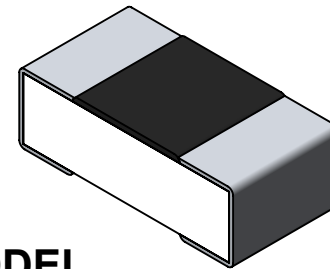

## MODEL

|             |          |                      |      |             |              |
|-------------|----------|----------------------|------|-------------|--------------|
| APPROVALS   | DATE     | <b>TopLine®</b>      |      |             |              |
| DRAWN T. Au | 05/17/12 |                      |      |             |              |
| ENG M. Hart | 05/17/12 | TITLE <b>SR01005</b> |      |             |              |
| MFG         |          | SMT RESISTOR         |      |             |              |
| QA          |          | SCALE                | SIZE | DRAWING NO. | REV          |
| CUST        |          |                      | A    | 120151      | A            |
| REVISED     |          | DO NOT SCALE DRAWING |      |             | SHEET 1 OF 3 |



# W4P1 CARRIER TAPE DIMENSION

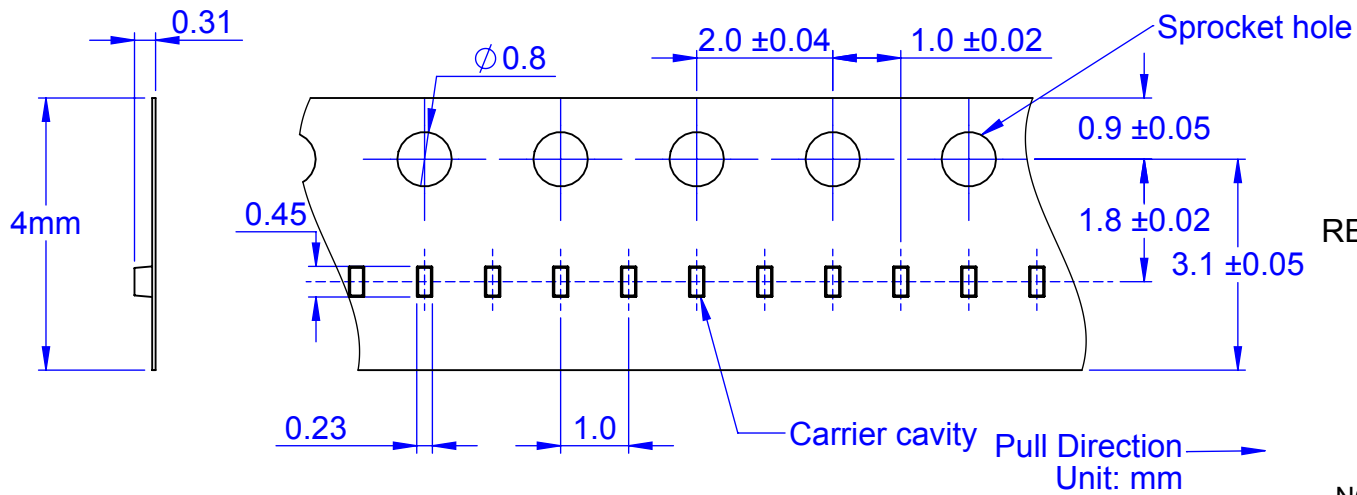

## W4P1 TAPE PART NUMBER SYSTEM

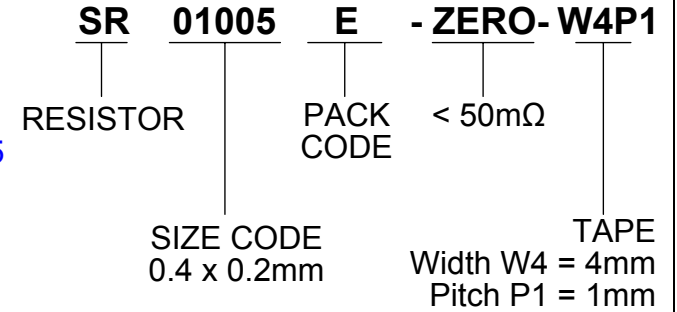

NOTE: For dummy resistor replace ZERO with blank

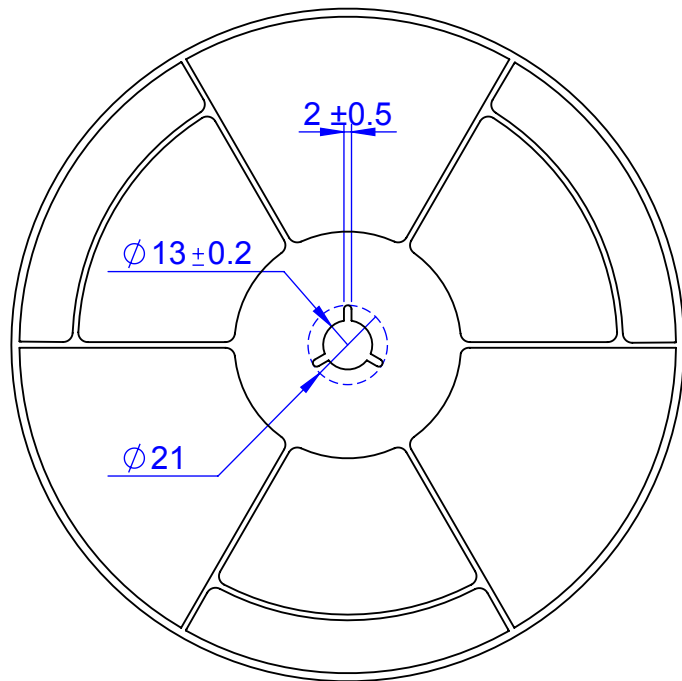

REEL DIMENSIONS

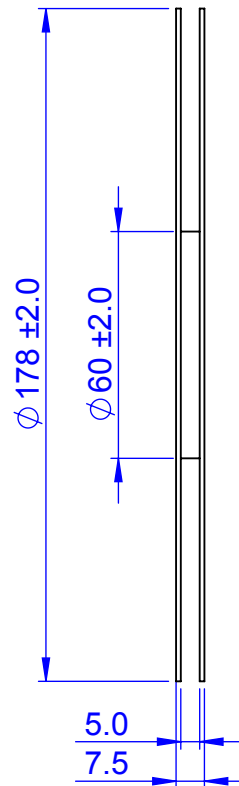

| PACK CODE |        |         |
|-----------|--------|---------|
| CODE      | QTY    | PACKAGE |
| E7A       | 40,000 | REEL    |
| E7B       | 20,000 | REEL    |
| E7C       | 10,000 | REEL    |
| E7D       | 5,000  | REEL    |
| E4A       | 1,000  | REEL    |

|             |          |                      |      |             |              |
|-------------|----------|----------------------|------|-------------|--------------|
| APPROVALS   | DATE     | <b>TopLine®</b>      |      |             |              |
| DRAWN T. Au | 05/17/12 |                      |      |             |              |
| ENG M. Hart | 05/17/12 | TITLE <b>SR01005</b> |      |             |              |
| MFG         |          | SMT RESISTOR         |      |             |              |
| QA          |          | SCALE                | SIZE | DRAWING NO. | REV          |
| CUST        |          |                      | A    | 120151      | A            |
| REVISED     |          | DO NOT SCALE DRAWING |      |             | SHEET 3 OF 3 |