

### TOP VIEW

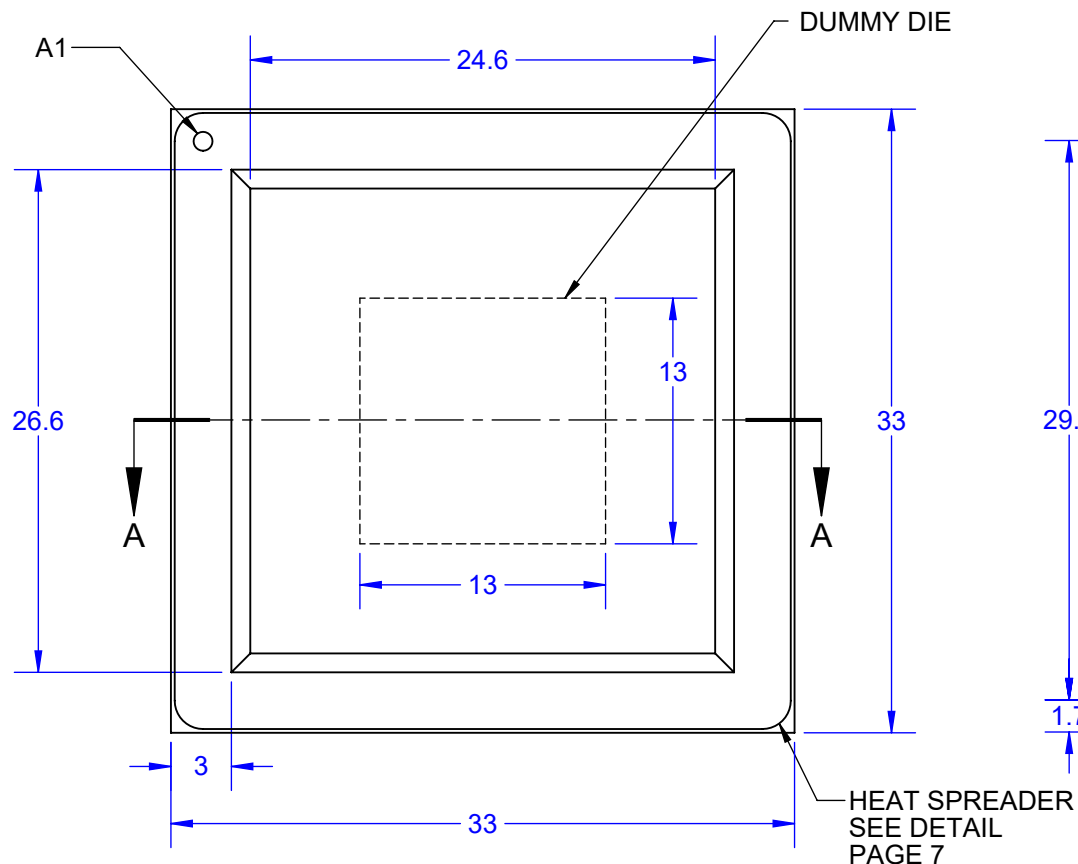

### BALL VIEW

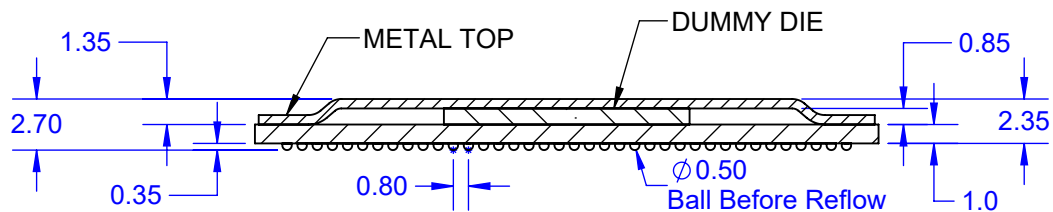
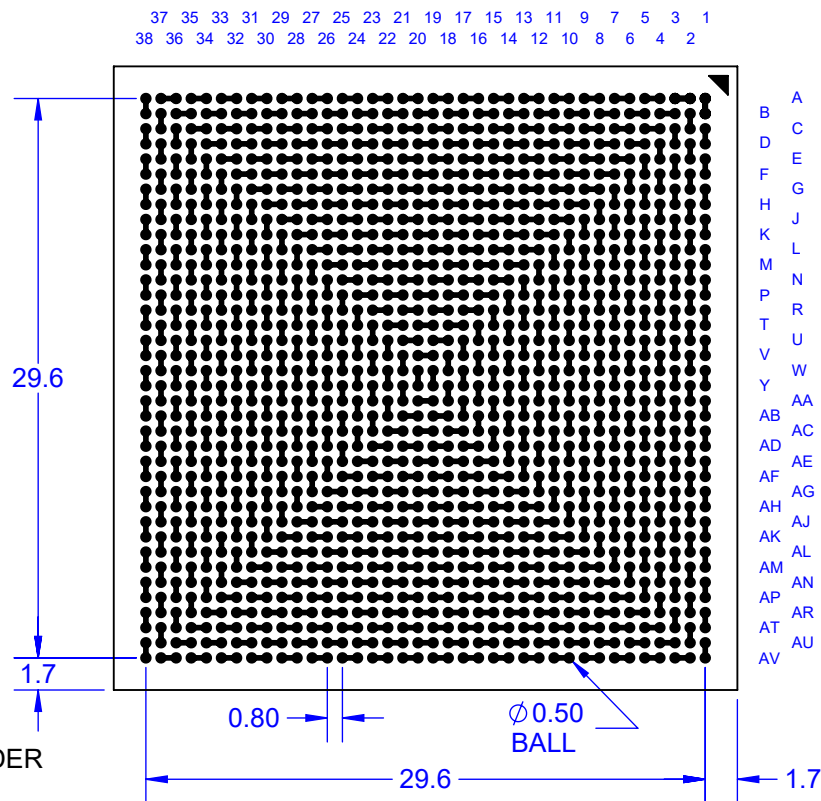

SECTION A-A

Notes: (Unless Otherwise Specified).

- 1) ALL DIMENSIONS ARE IN MM.
- 2) SOLDER BALL ALLOY: SEE PART NUMBER TABLE.
- 3) BALL DIAMETER (BEFORE REFLOW) 0.50mm [20 MIL].
- 4) SOLDER MASK DEFINED PAD OPENING: 0.40mm [16 MIL].
- 5) PAD Cu DIAMETER: 0.508mm [20 MIL].
- 6) SUBSTRATE MATERIAL: BT.
- 7) DUMMY DIE: Si (SILICON).
- 8) DAISY CHAIN PATTERN (SEE PAGE 2).
- 9) MSL-3 RECOMMENDED BAKING 24 HOURS @ 125°C TO REMOVE MOISTURE PRIOR TO SOLDERING TO PC BOARD.

#### PART NUMBER TABLE

PART NUMBER	BALL METAL	BALL ALLOY	RoHS	Si DIE
SBGA1444T.8C-DC389D	Sn96.5/Ag3.0/Cu0.5	SAC305	YES	YES
SBGA1444T.8-DC389D	Sn63/Pb37	Sn63	NO	YES

APPROVALS	DATE				
DRAWN T. Au	5/29/2025				
ENG M. Hart	5/29/2025	TITLE SBGA1444T.8-DC389D DAISY CHAIN DUMMY			
MFG		SCALE 2.5:1	SIZE A	DRAWING NO. 583895	REV B
QA					
CUST		DO NOT SCALE DRAWING			SHEET 1 OF 9
REVISED					

# BALL VIEW

37 35 33 31 29 27 25 23 21 19 17 15 13 11 9 7 5 3 1  
38 36 34 32 30 28 26 24 22 20 18 16 14 12 10 8 6 4 2

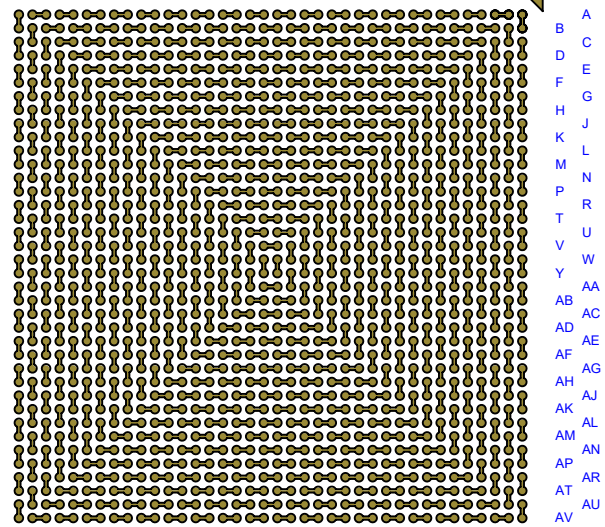

# BOTTOM SIDE (TOP X-RAY VIEW)

1 3 5 7 9 11 13 15 17 19 21 23 25 27 29 31 33 35 37  
2 4 6 8 10 12 14 16 18 20 22 24 26 28 30 32 34 36 38

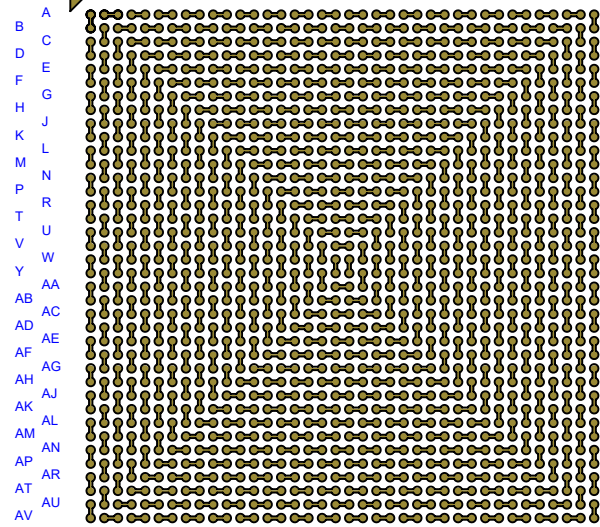

T+ 1 3 5 7 9 11 13 15 17 19 21 23 25 27 29 31 33 35 37 T-  
2 4 6 8 10 12 14 16 18 20 22 24 26 28 30 32 34 36 38

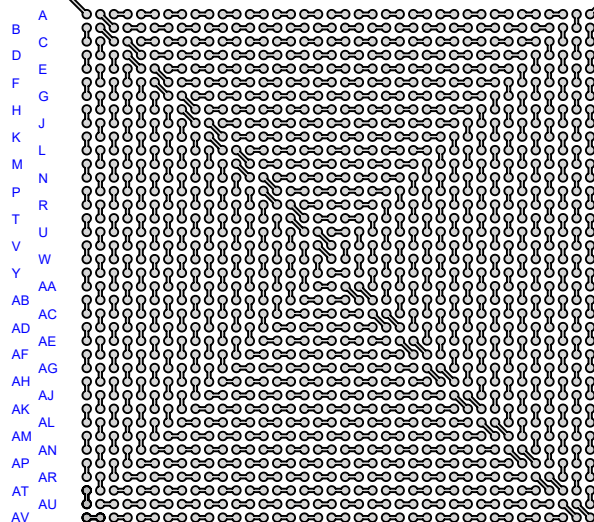

# TEST VEHICLE BOARD

T+ 1 3 5 7 9 11 13 15 17 19 21 23 25 27 29 31 33 35 37 T-  
2 4 6 8 10 12 14 16 18 20 22 24 26 28 30 32 34 36 38

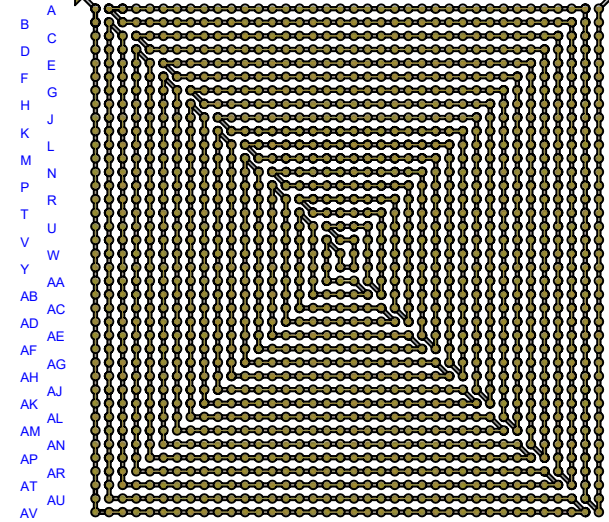

# AFTER MOUNTING

Notes: (Unless Otherwise Specified).

- 1) PCB BOARD DIMENSIONS ARE PRESENTED ONLY AS A GUIDELINE DESIGNERS SHOULD USE THEIR OWN KNOWLEDGE WHEN DESIGNING THE PCB.
- 2) PCB Cu BALL PAD DIAMETER: 0.508mm [20 MIL].
- 3) PCB DAISY CHAIN TRACING LINE WIDTH: 0.20mm [8 MIL].
- 4) SMD (SOLDERMASK DEFINED) PAD OPENING: 0.40mm [16 MIL].



TITLE			
SBGA1444T.8-DC389D DAISY CHAIN DUMMY			
SCALE	SIZE	DRAWING NO.	REV
5:2	A	583895	B
DO NOT SCALE DRAWING			SHEET 2 OF 9

# BALL VIEW

37 35 33 31 29 27 25 23 21 19 17 15 13 11 9 7 5 3 1  
 38 36 34 32 30 28 26 24 22 20 18 16 14 12 10 8 6 4 2

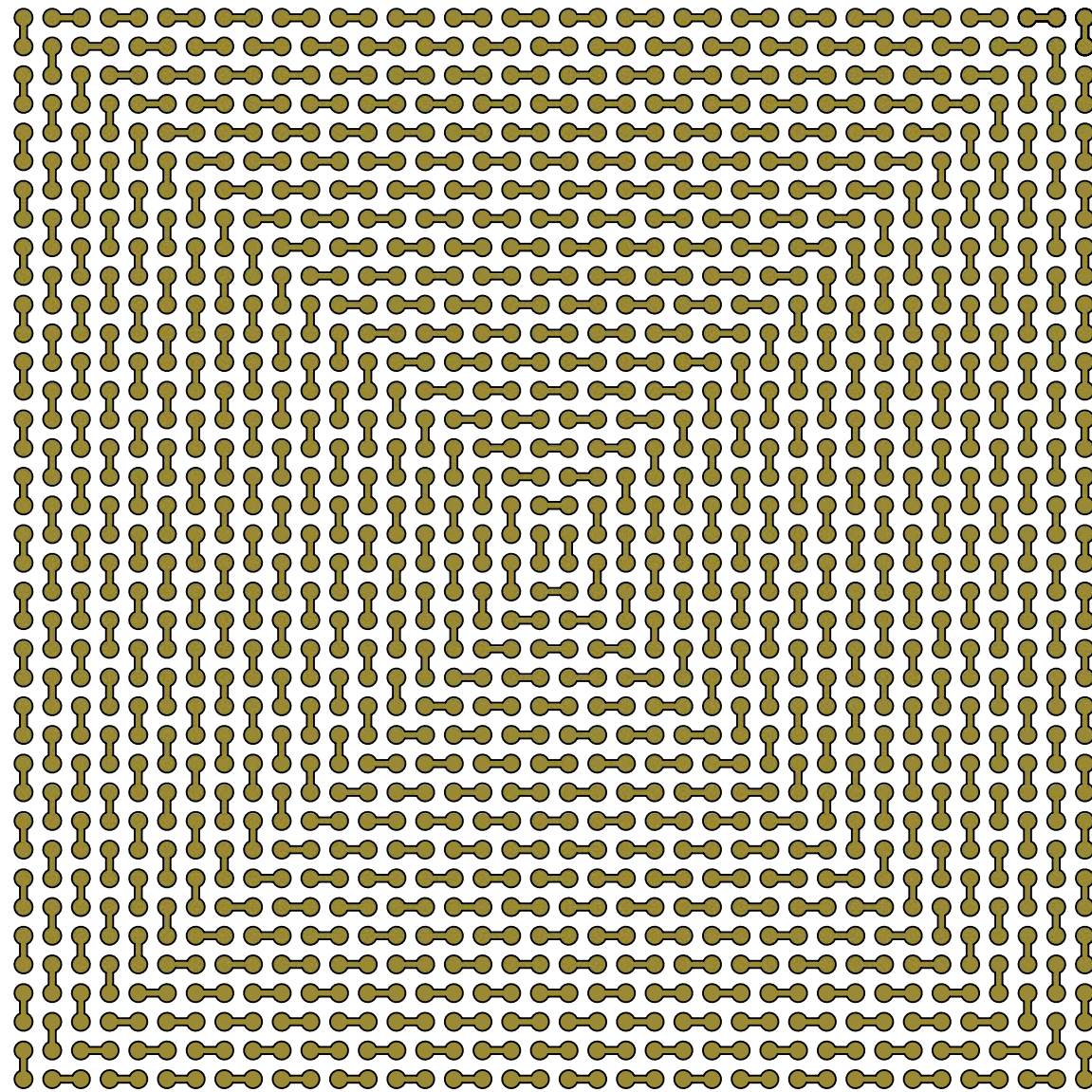

A  
 B  
 C  
 D  
 E  
 F  
 G  
 H  
 J  
 K  
 L  
 M  
 N  
 P  
 R  
 T  
 U  
 V  
 W  
 Y  
 AA  
 AB  
 AC  
 AD  
 AE  
 AF  
 AG  
 AH  
 AJ  
 AK  
 AL  
 AM  
 AN  
 AP  
 AR  
 AT  
 AU  
 AV

<b>TopLine®</b>			
TITLE		SBGA1444T.8-DC389D DAISY CHAIN DUMMY	
SCALE	SIZE	DRAWING NO.	REV
5:1	A	583895	B
DO NOT SCALE DRAWING			SHEET 3 OF 9

# BOTTOM SIDE (TOP X-RAY VIEW)

1 3 5 7 9 11 13 15 17 19 21 23 25 27 29 31 33 35 37  
 2 4 6 8 10 12 14 16 18 20 22 24 26 28 30 32 34 36 38

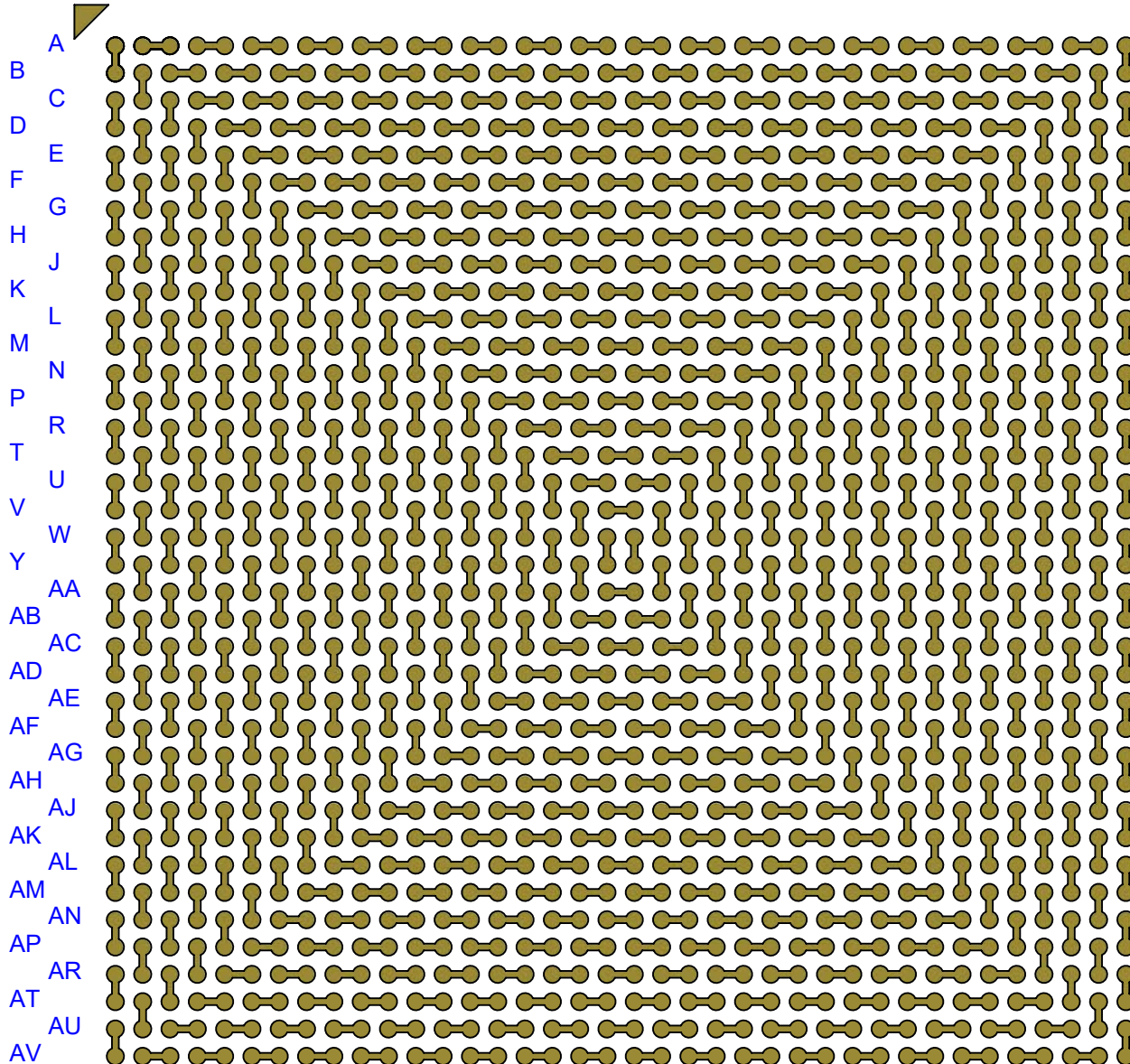

<b>TopLine®</b>			
TITLE		SBGA1444T.8-DC389D DAISY CHAIN DUMMY	
SCALE	SIZE	DRAWING NO.	REV
5:1	A	583895	B
DO NOT SCALE DRAWING			SHEET 4 OF 9

# TEST VEHICLE BOARD

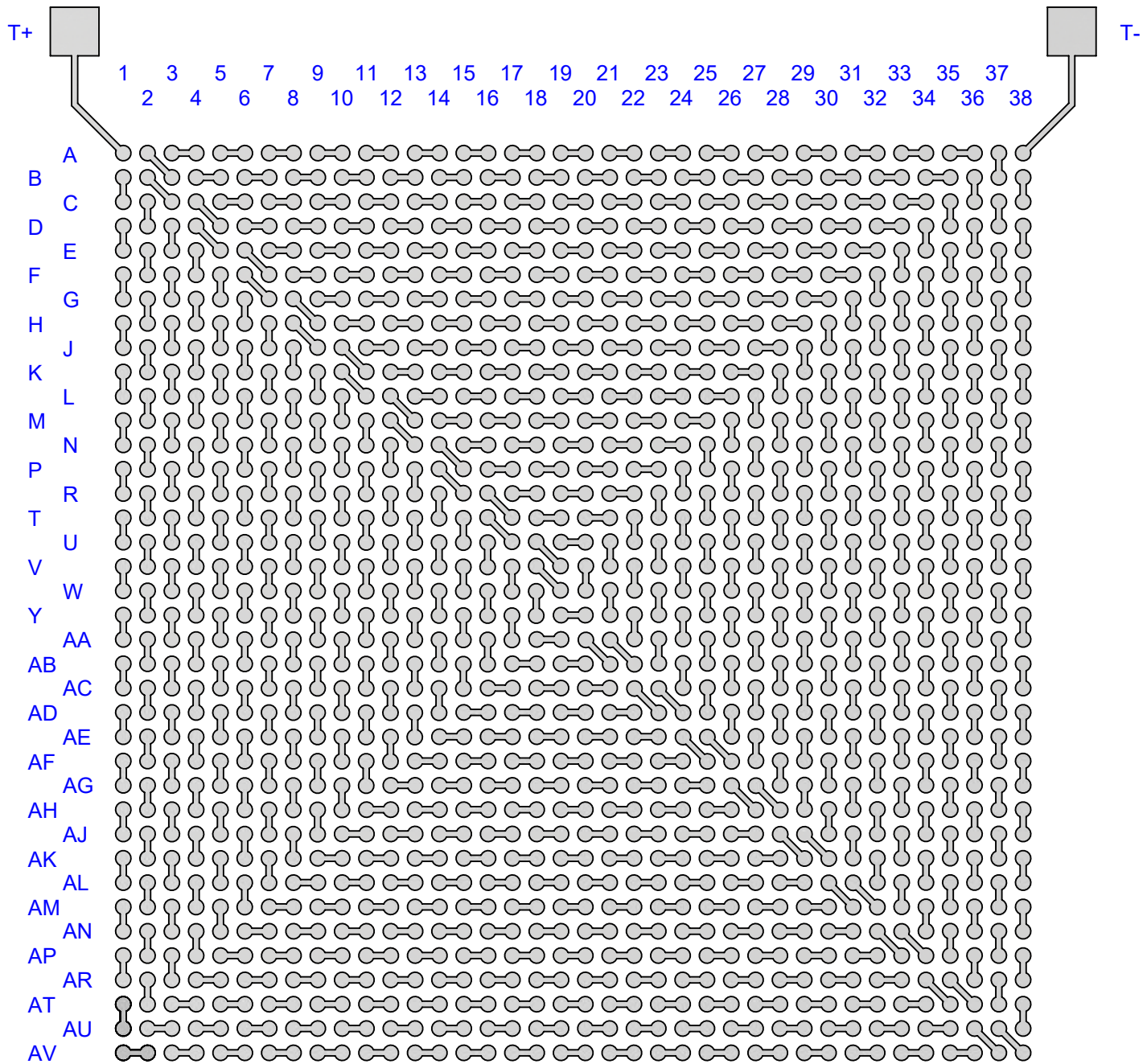

<b>TopLine<sup>®</sup></b>			
TITLE		SBGA1444T.8-DC389D DAISY CHAIN DUMMY	
SCALE	SIZE	DRAWING NO.	REV
5:1	A	583895	B
DO NOT SCALE DRAWING			SHEET 5 OF 9

# AFTER MOUNTING TO TEST BOARD

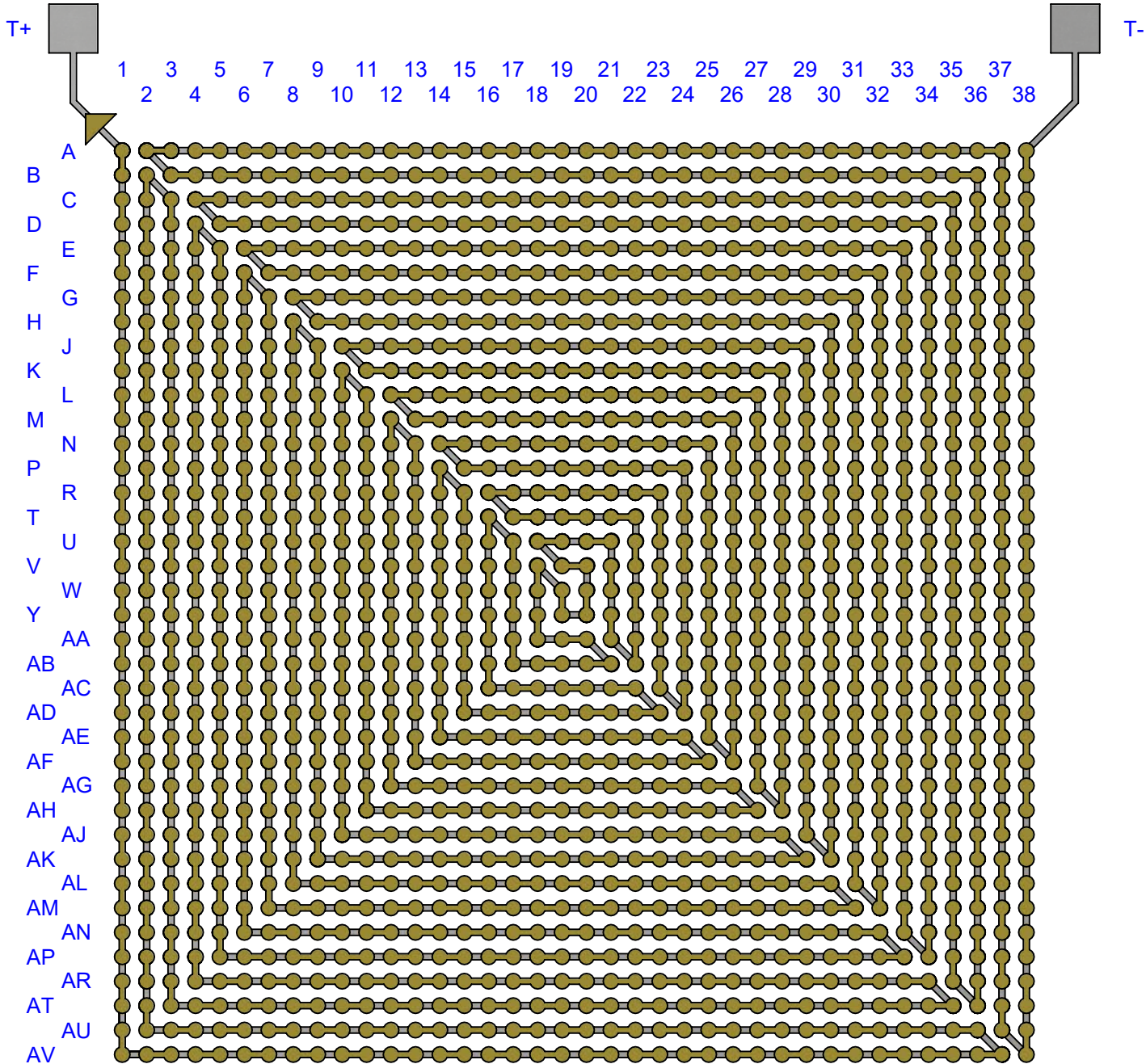

<b>TopLine<sup>®</sup></b>			
TITLE SBGA1444T.8-DC389D DAISY CHAIN DUMMY			
SCALE	SIZE	DRAWING NO.	REV
5:1	A	583895	B
DO NOT SCALE DRAWING			SHEET 6 OF 9

# HEAT SPREADER

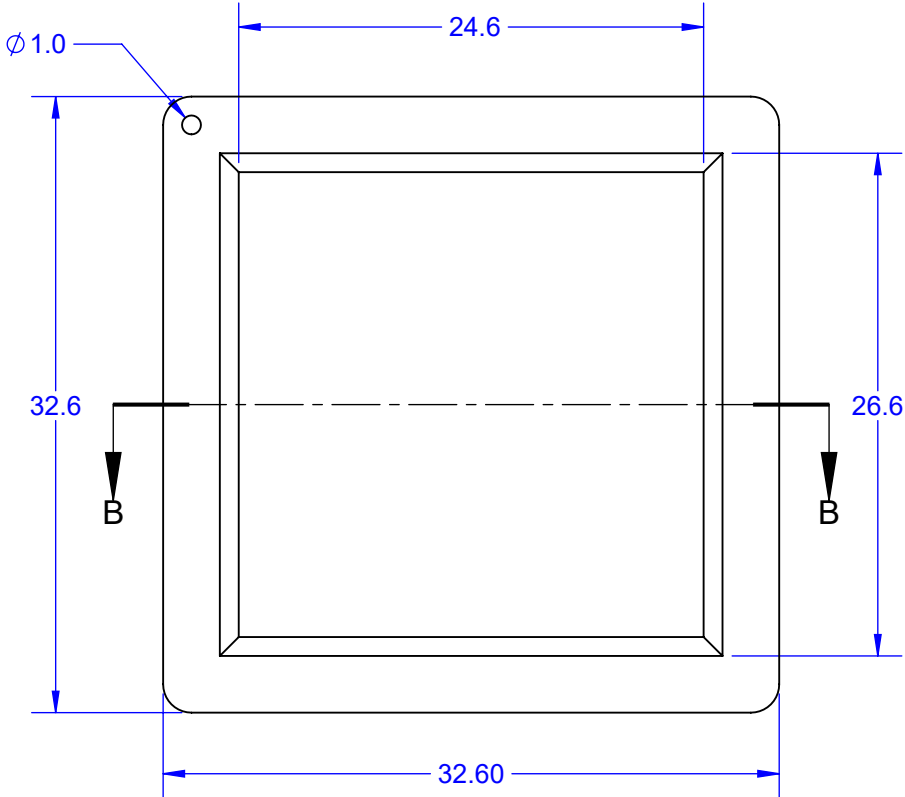

TOP

MODEL



CAVITY

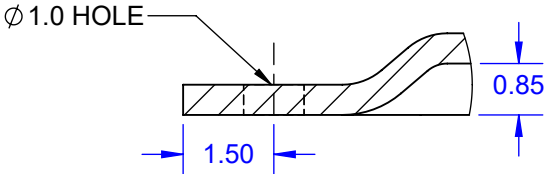

DETAIL E  
SCALE 8 : 1

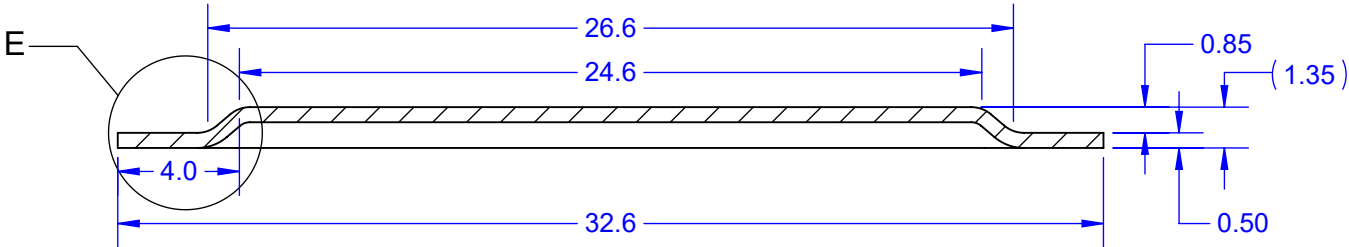

SECTION B-B  
SCALE 4 : 1

\* ADD 0.13MM SEALANT

<b>TopLine®</b>			
TITLE SBGA1444T.8-DC389D DAISY CHAIN DUMMY			
SCALE 2.5:1	SIZE A	DRAWING NO. 583895	REV B
DO NOT SCALE DRAWING			SHEET 7 OF 9

# MODEL

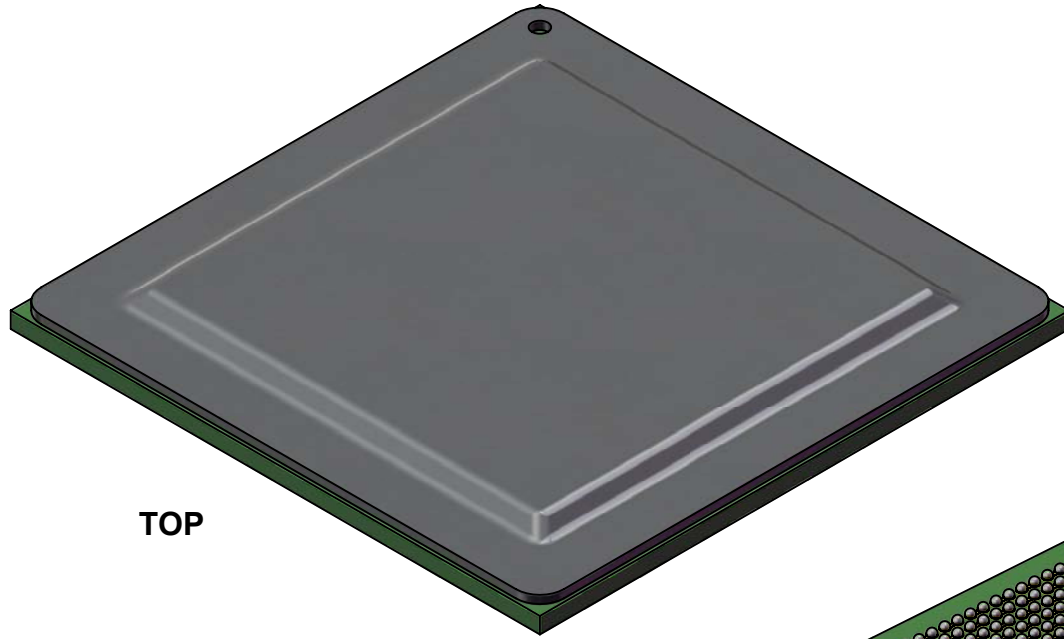

TOP

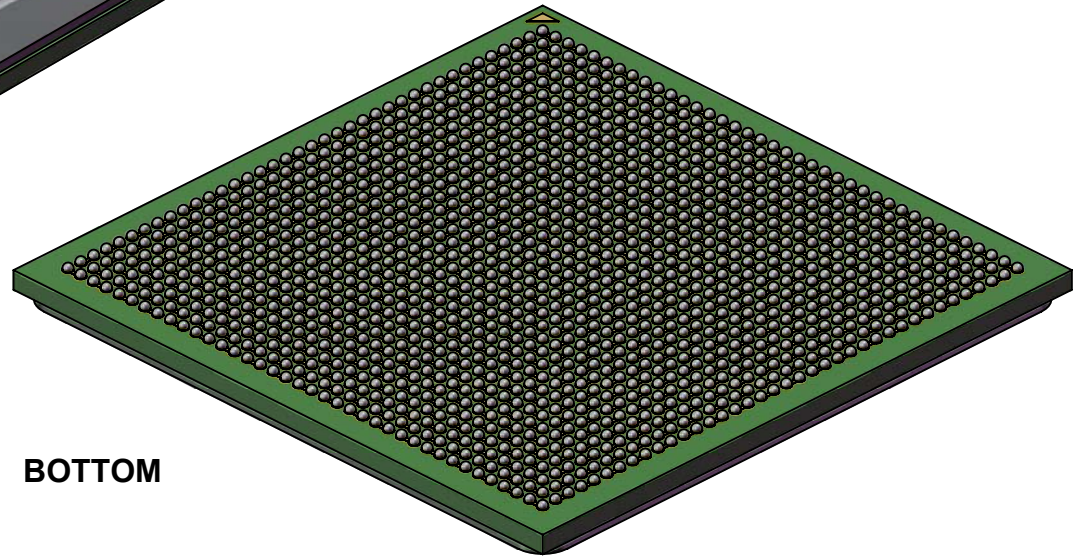

BOTTOM

**TopLine**<sup>®</sup>

TITLE SBGA1444T.8-DC389D  
DAISY CHAIN DUMMY

SCALE	SIZE	DRAWING NO.	REV
3:1	A	583895	B

DO NOT SCALE DRAWING

SHEET 8 OF 9

# BOTTOM SOLDER MASK (RIGHT READING)

37 35 33 31 29 27 25 23 21 19 17 15 13 11 9 7 5 3 1  
38 36 34 32 30 28 26 24 22 20 18 16 14 12 10 8 6 4 2

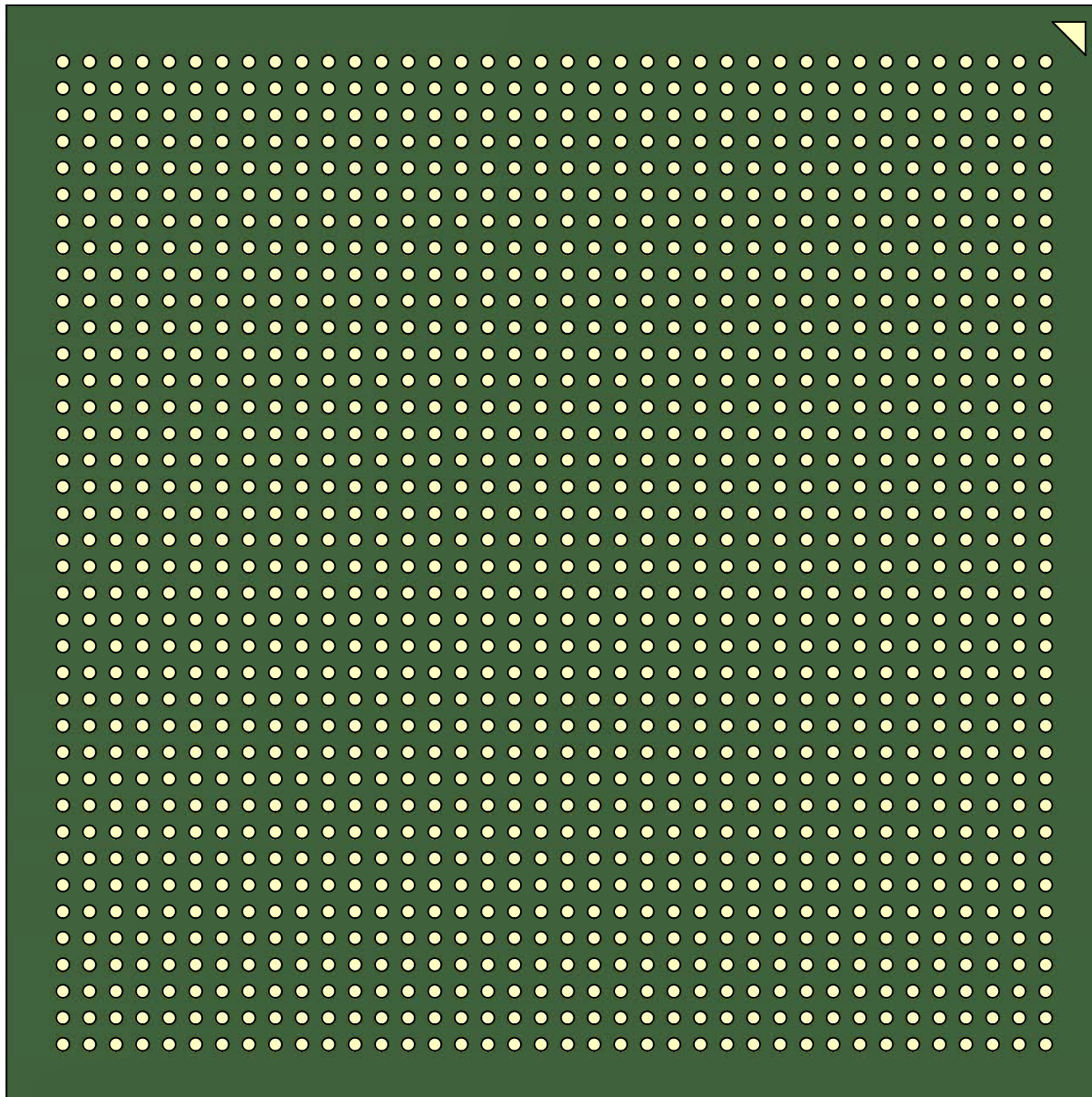

A  
B  
C  
D  
E  
F  
G  
H  
J  
K  
L  
M  
N  
P  
R  
T  
U  
V  
W  
Y  
AA  
AB  
AC  
AD  
AE  
AF  
AG  
AH  
AJ  
AK  
AL  
AM  
AN  
AP  
AR  
AT  
AU  
AV

<b>TopLine®</b>			
TITLE SBGA1444T.8-DC389D DAISY CHAIN DUMMY			
SCALE 5:1	SIZE A	DRAWING NO. 583895	REV B
DO NOT SCALE DRAWING			SHEET 9 OF 9