

### TOP VIEW

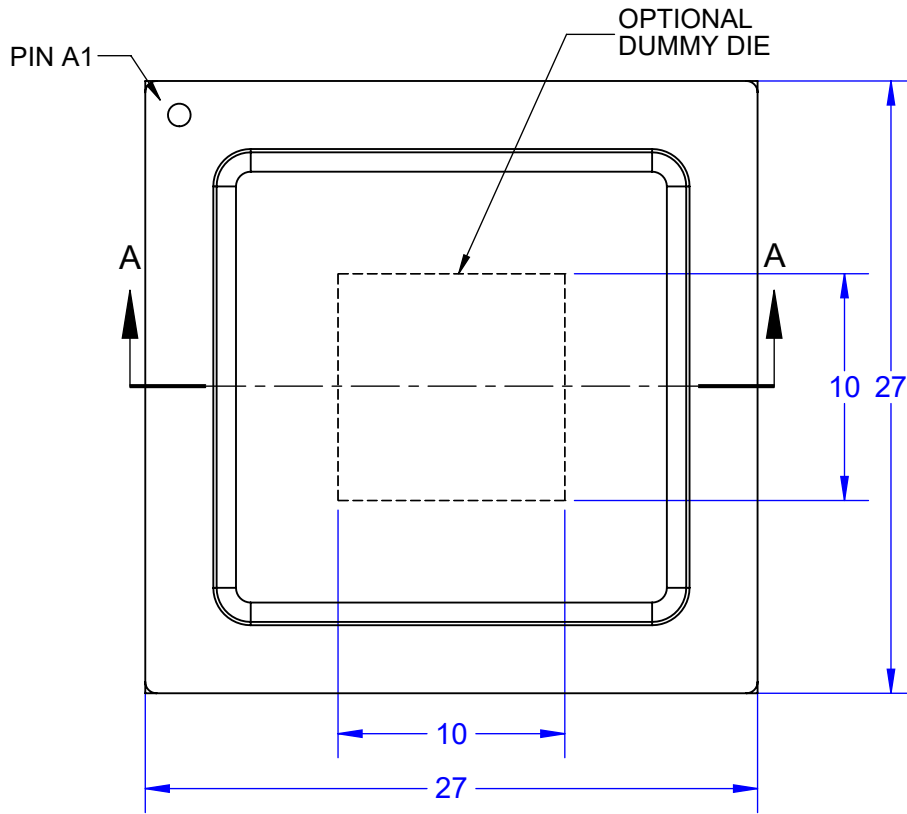

### BALL VIEW

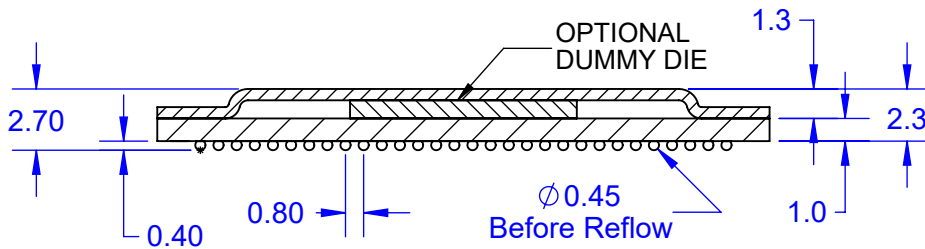
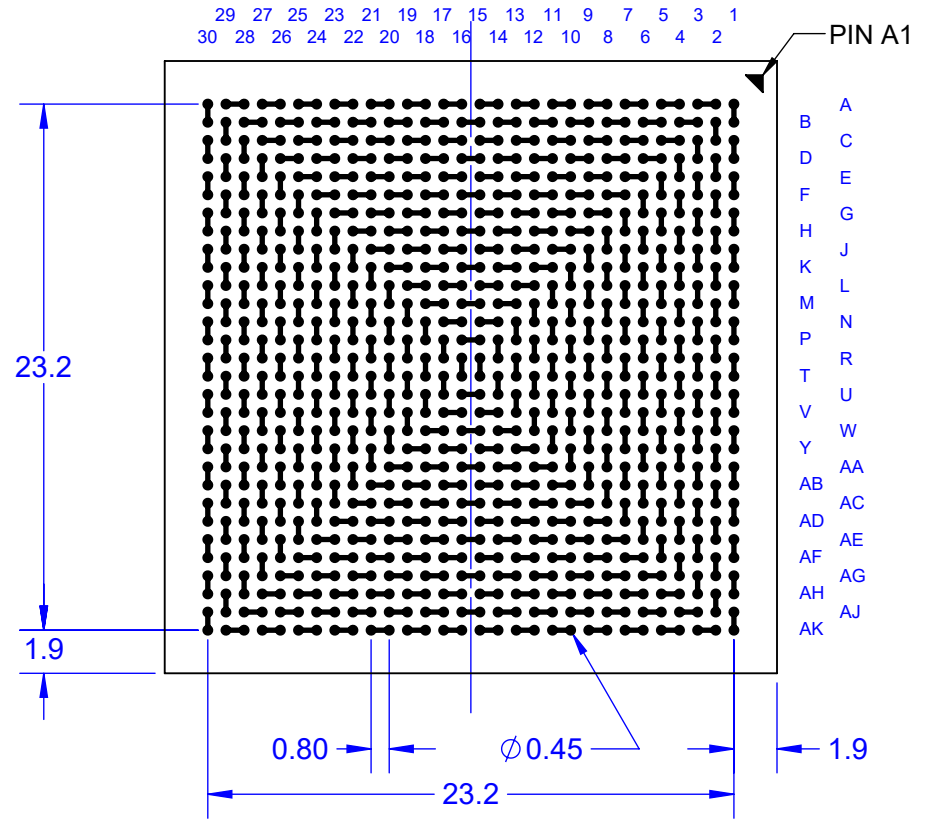

SECTION A-A

Notes: (Unless Otherwise Specified).

- 1) ALL DIMENSIONS ARE IN MM.
- 2) SOLDER BALL ALLOY: SEE PART NUMBER TABLE.
- 3) BALL DIAMETER (BEFORE REFLOW): 0.45mm.
- 4) SOLDER MASK DEFINED PAD OPENING: 0.40mm (16 MIL).
- 5) PAD Cu DIAMETER: 0.508mm (20 MIL).
- 6) SUBSTRATE MATERIAL: BT.
- 7) DUMMY DIE IS OPTIONAL.
- 8) DAISY CHAIN PATTERN (SEE PAGE 2).
- 9) MSL-3 RECOMMENDED BAKING 24 HOURS @ 125°C TO REMOVE MOISTURE PRIOR SOLDERING TO PC BOARD.

#### PART NUMBER TABLE

PART NUMBER	BALL ALLOY	Pb-FREE	RoHS	Si DIE
SBGA900T.8C-DC309D	Sn96.5/Ag3.0/Cu0.5	YES	YES	YES
SBGA900T.8-DC309D	Sn63/Pb37	NO	NO	YES

APPROVALS	DATE				
DRAWN T.Au	5/29/2025				
ENG M. Hart	5/29/2025	TITLE SBGA900T.8-DC309D DAISY CHAIN DUMMY			
MFG		SCALE 3:1	SIZE A	DRAWING NO. 583095	REV C
QA		DO NOT SCALE DRAWING			SHEET 1 OF 5
CUST					
REVISED					

### BALL VIEW

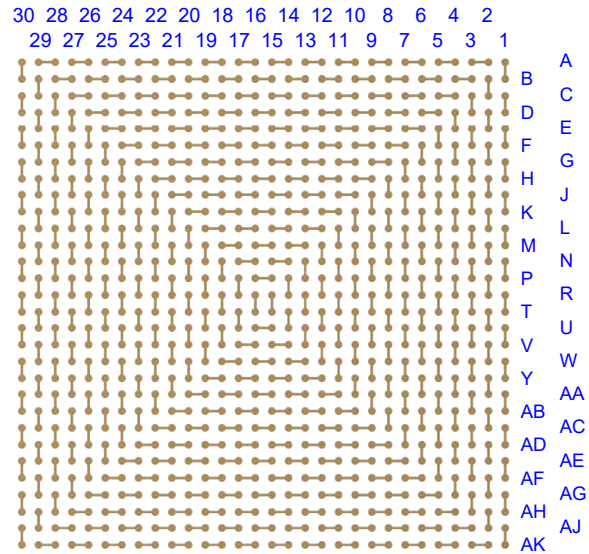

### BOTTOM SIDE (TOP X-RAY VIEW)

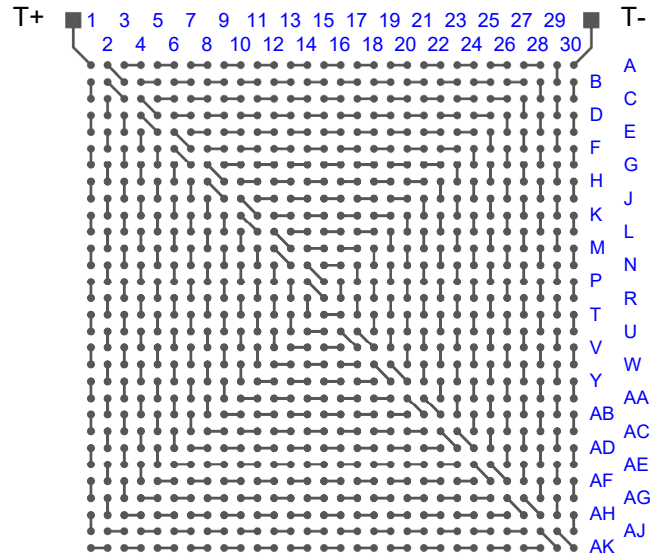
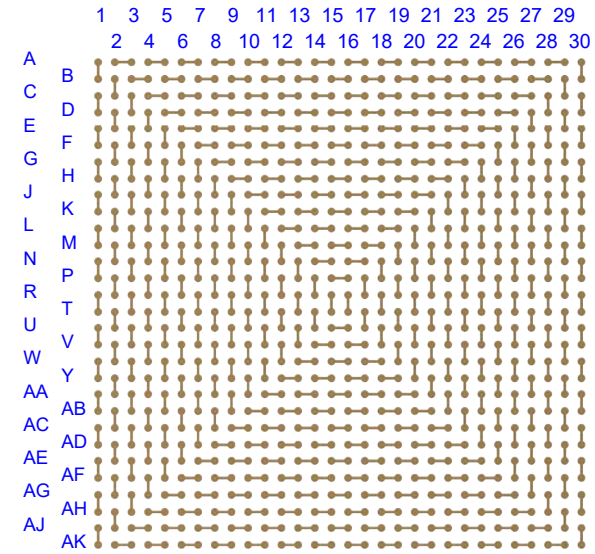

**TEST VEHICLE BOARD**

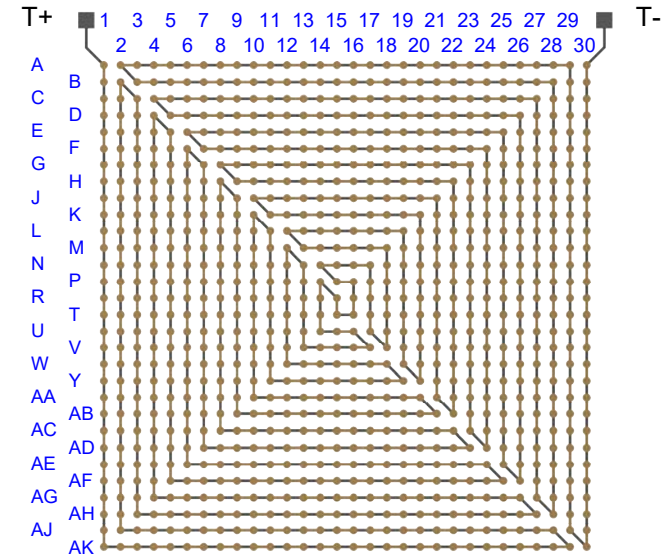

**AFTER MOUNTING**

**Notes:**

- 1) PCB BOARD DIMENSIONS ARE PRESENTED ONLY AS A GUIDELINE. DESIGNERS SHOULD USE THEIR OWN EXPERIENCE WHEN DESIGNING PCB.
- 2) PCB Cu BALL PAD DIAMETER 0.508mm (20 MIL).
- 3) PCB DAISY CHAIN TRACING LINE WIDTH 0.152mm (6 MIL).
- 4) SMD (SOLDER MASK DEFINED) PAD OPENING: 0.40mm (16 MIL).

<b>TopLine®</b>			
TITLE		SBGA900T.8-DC309D DAISY CHAIN DUMMY	
SCALE	SIZE	DRAWING NO.	REV
3:1	A	583095	C
DO NOT SCALE DRAWING			SHEET 2 OF 5

MODEL

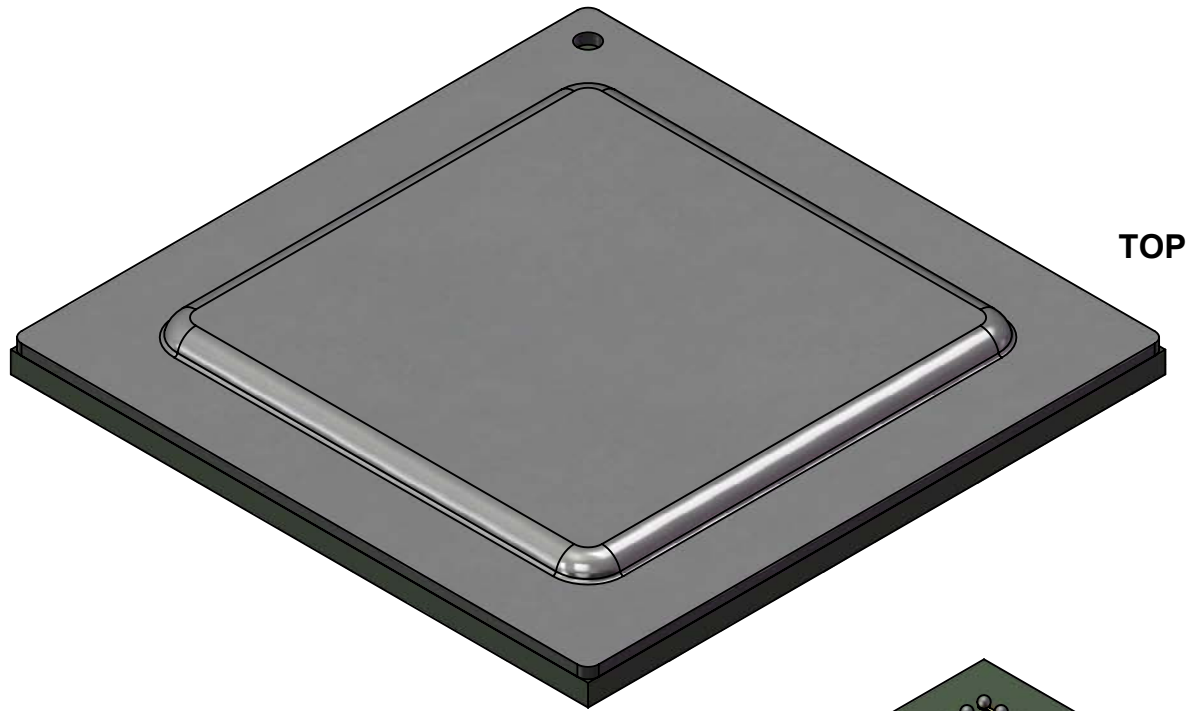

TOP

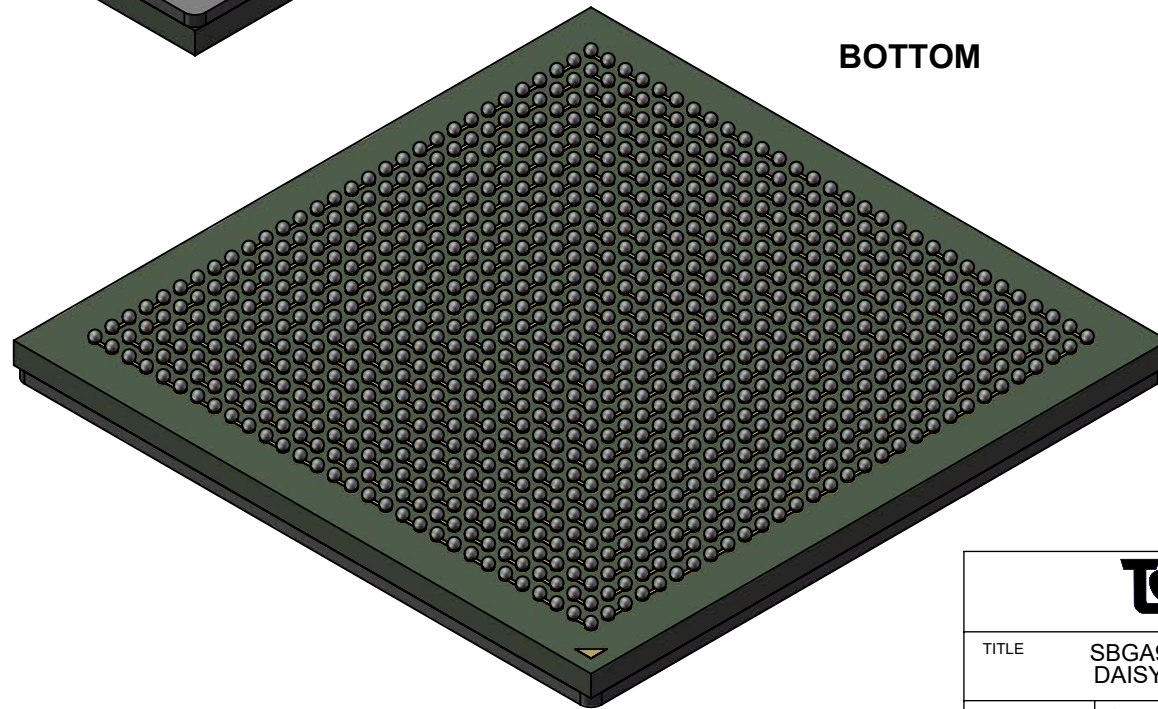

BOTTOM

**TopLine**<sup>®</sup>

TITLE SPGA900T.8-DC309D  
DAISY CHAIN DUMMY

SCALE 3:1	SIZE A	DRAWING NO. 583095	REV C
--------------	-----------	-----------------------	----------

DO NOT SCALE DRAWING

SHEET 3 OF 5

# HEAT SPREADER

TOP



MODEL

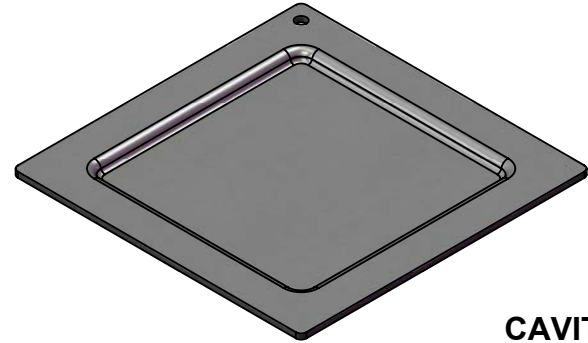

CAVITY

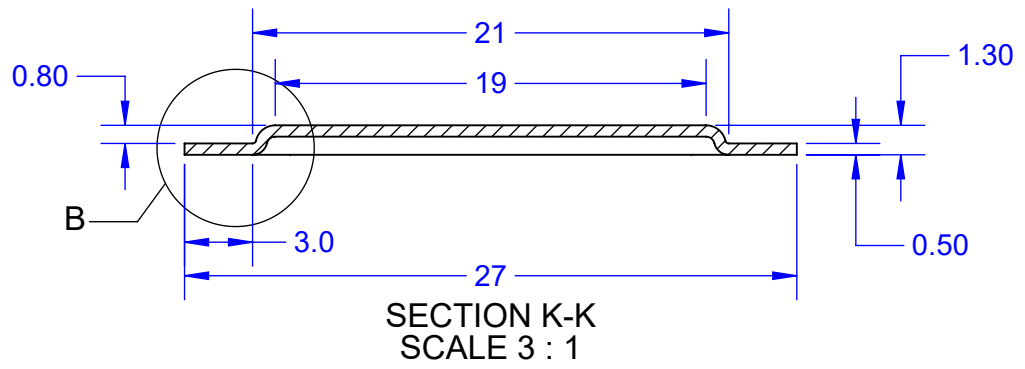
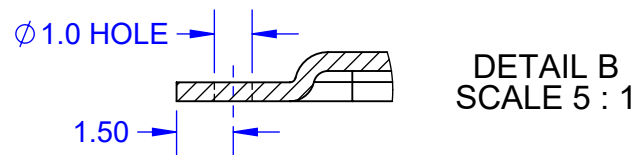
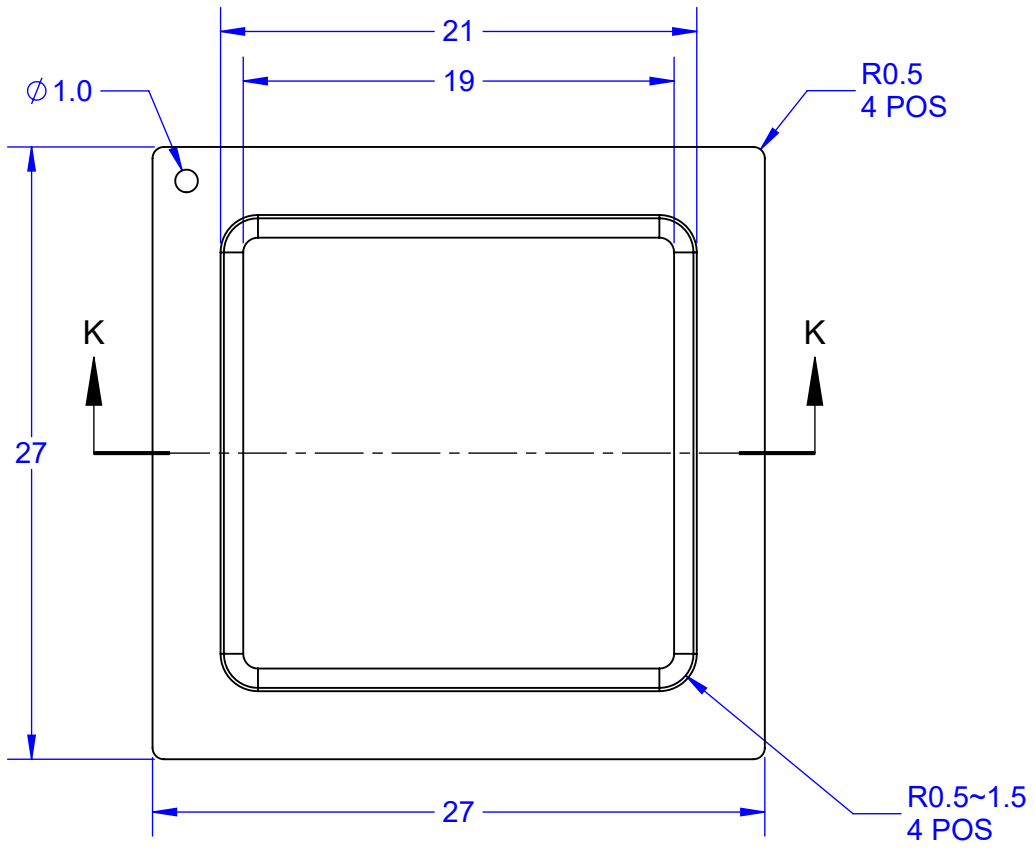

APPROVALS	DATE	<b>TopLine<sup>®</sup></b>			
DRAWN T. Au	5/29/2025				
ENG M. Hart	5/29/2025	TITLE H-CAP27A DOME LID			
MFG		SCALE 2.5:1	SIZE A	DRAWING NO. 227710	REV A
QA		DO NOT SCALE DRAWING			SHEET 4 OF 5
CUST					
REVISED					

# BOTTOM SOLDERMASK (RIGHT READING)

30 28 26 24 22 20 18 16 14 12 10 8 6 4 2  
29 27 25 23 21 19 17 15 13 11 9 7 5 3 1

A  
B  
C  
D  
E  
F  
G  
H  
J  
K  
L  
M  
N  
P  
R  
T  
U  
V  
W  
Y  
AA  
AB  
AC  
AD  
AE  
AF  
AG  
AH  
AJ  
AK

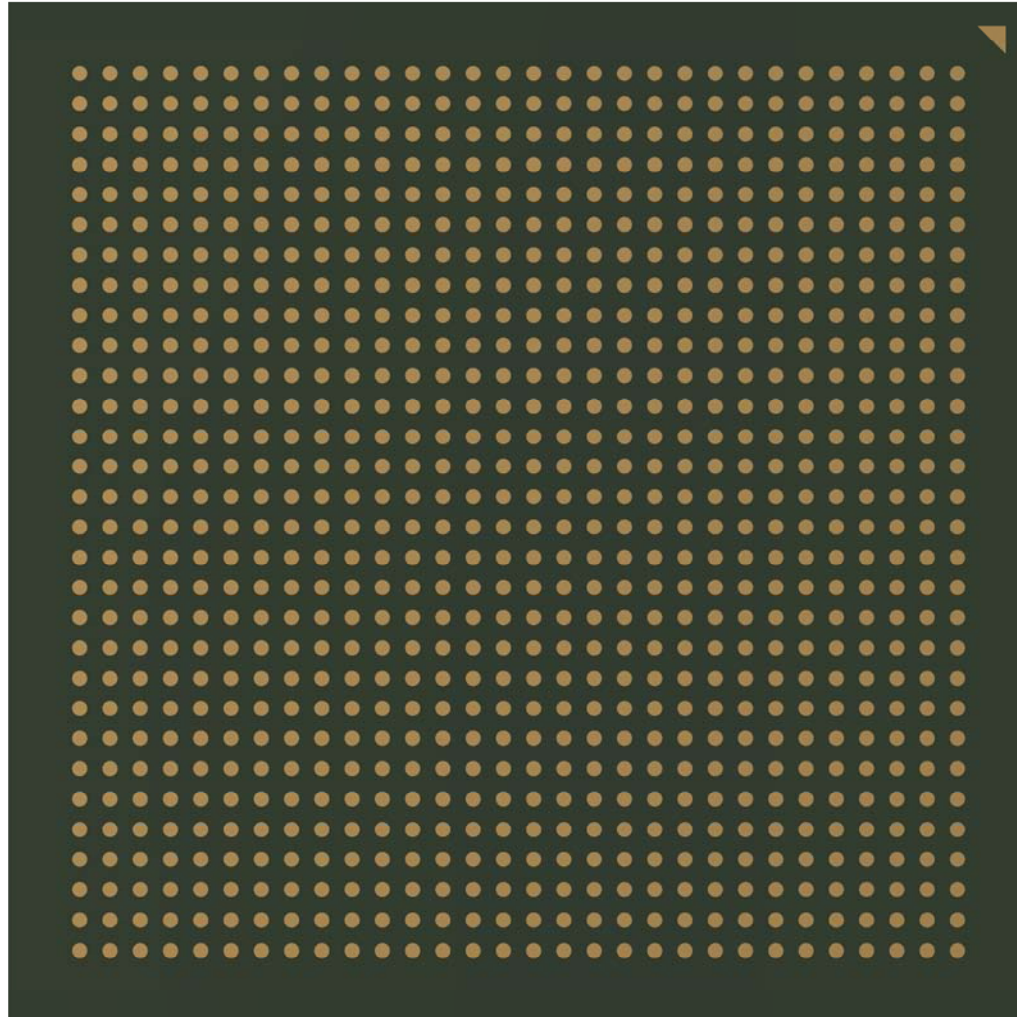

<b>TopLine®</b>			
TITLE		SBGA900T.8-DC309D DAISY CHAIN DUMMY	
SCALE	SIZE	DRAWING NO.	REV
3:1	A	583095	C
DO NOT SCALE DRAWING			SHEET 5 OF 5