

TOP VIEW

BOTTOM VIEW

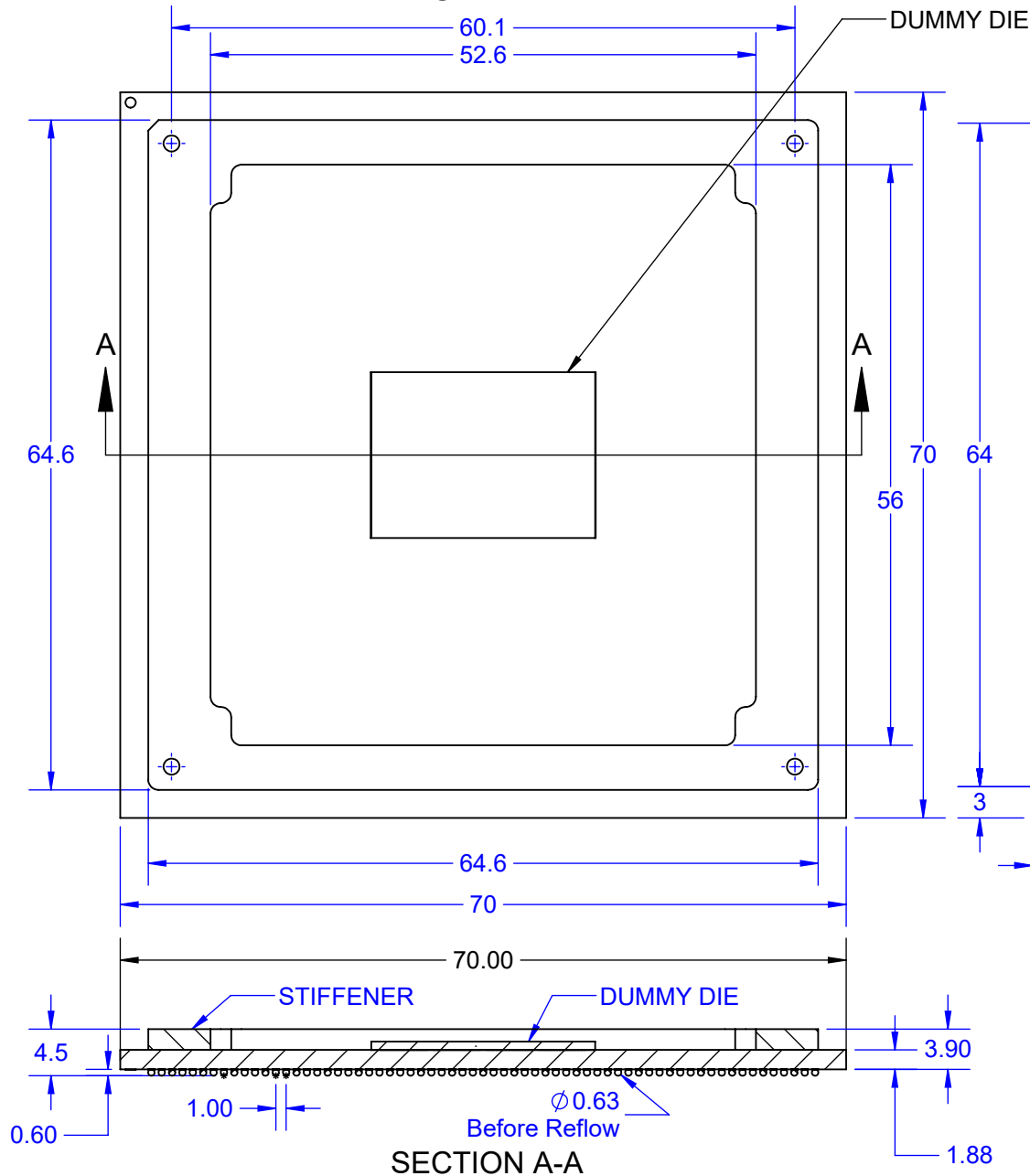

64 62 60 58 56 54 52 50 48 46 44 42 40 38 36 34 32 30 28 26 24 22 20 18 16 14 12 10 8 6 4 2
65 63 61 59 57 55 53 51 49 47 45 43 41 39 37 35 33 31 29 27 25 23 21 19 17 15 13 11 9 7 5 3 1

A
B
C
D
E
F
G
H
J
K
L
M
N
P
R
T
U
V
Y
AA
AB
AC
AD
AE
AF
AG
AH
AJ
AK
AL
AM
AN
AP
AR
AT
AU
AV
AW
AY
BA
BB
BC
BD
BE
BF
BG
BH
BJ
BK
BL
BM
BN
BP
BR
BT
BU
BV
BY
CA
CB
CC
CD
CE

- Notes: (Unless Otherwise Specified).
 1) ALL DIMENSIONS ARE IN MM.
 2) SOLDER BALL ALLOY: SEE PART NUMBER TABLE.
 3) BALL DIAMETER (BEFORE REFLOW): 0.635mm (25 MIL).
 4) SOLDER MASK DEFINED PAD OPENING: 0.50mm (19.7 MIL).
 5) PAD Cu DIAMETER: 0.635mm (25 MIL).
 6) SUBSTRATE MATERIAL: ORGANIC.
 7) DUMMY DIE Si (SILICON) 21.6 x 16 x .787mm.
 8) DAISY CHAIN PATTERN (SEE PAGE 2).
 9) MSL-3 RECOMMENDED BAKING 24 HOURS @ 125°C TO REMOVE MOISTURE PRIOR SOLDERING TO PC BOARD.

SECTION A-A

PART NUMBER TABLE				
PART NUMBER	BALL ALLOY	BALL ALLOY	RoHS	Si DIE
XBGA4201T1.0C-DC659D	Sn96.5/Ag3.0/Cu0.5	SAC305	YES	YES
XBGA4201T1.0-DC659D	Sn63/Pb37	Sn63	NO	YES

NOTE: SEE PAGE 7 OTHER BALL ALLOYS

APPROVALS	DATE				
DRAWN T. Au	7/16/2025				
ENG M. Hart	7/16/2025	TITLE XBGA4201T1.0-DC659D DAISY CHAIN DUMMY			
MFG		SCALE	SIZE	DRAWING NO.	REV
QA		3:2	A	516596	A
CUST		DO NOT SCALE DRAWING			SHEET 1 OF 7
REVISED					

BALL VIEW

65 63 61 59 57 55 53 51 49 47 45 43 41 39 37 35 33 31 29 27 25 23 21 19 17 15 13 11 9 7 5 3 1
 64 62 60 58 56 54 52 50 48 46 44 42 40 38 36 34 32 30 28 26 24 22 20 18 16 14 12 10 8 6 4 2

PIN A1

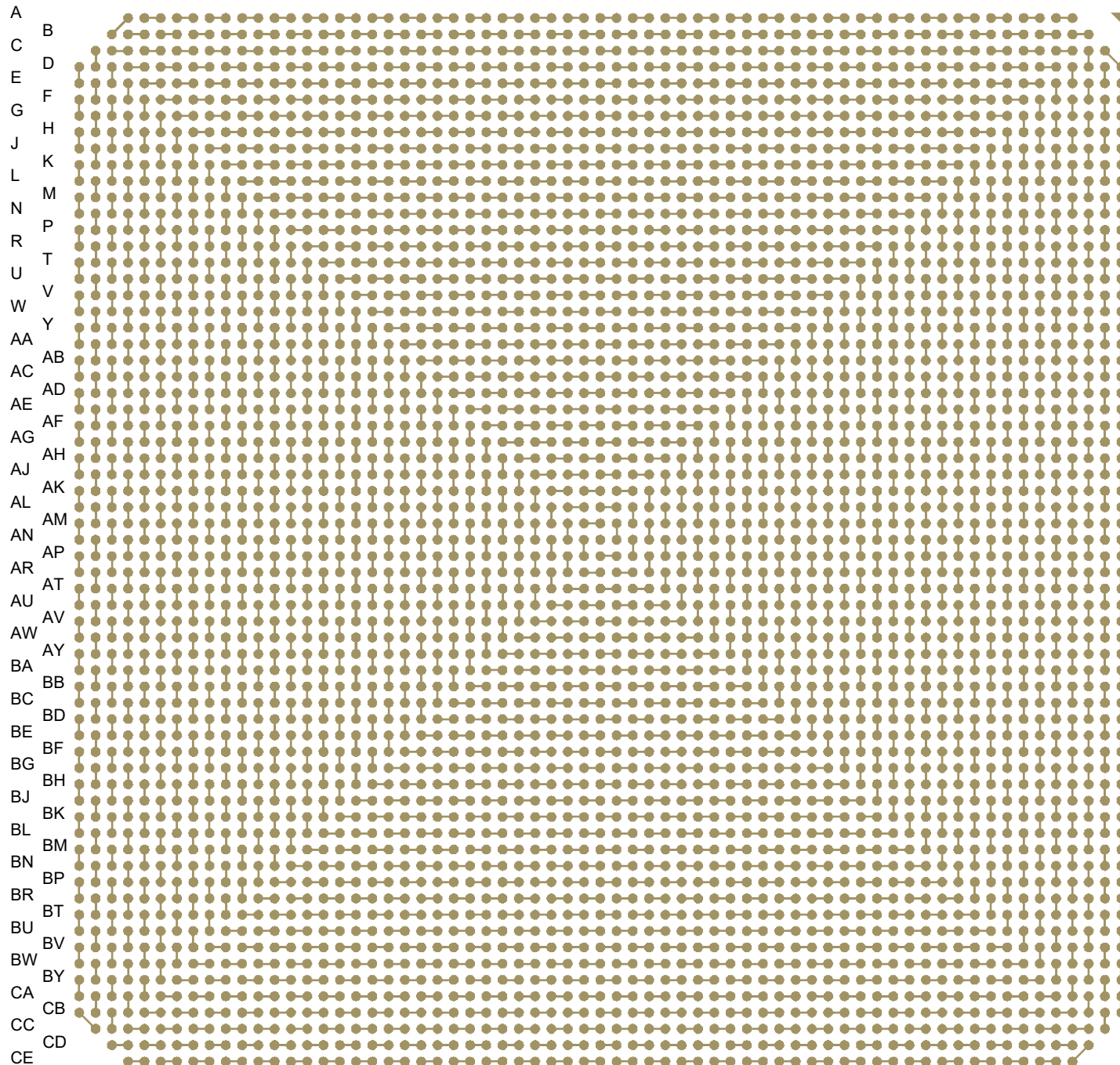

TopLine®			
TITLE XBG4201T1.0-DC659D DAISY CHAIN DUMMY			
SCALE 2.75:1	SIZE A	DRAWING NO. 516596	REV A
DO NOT SCALE DRAWING		SHEET 2 OF 7	

METAL STIFFENER

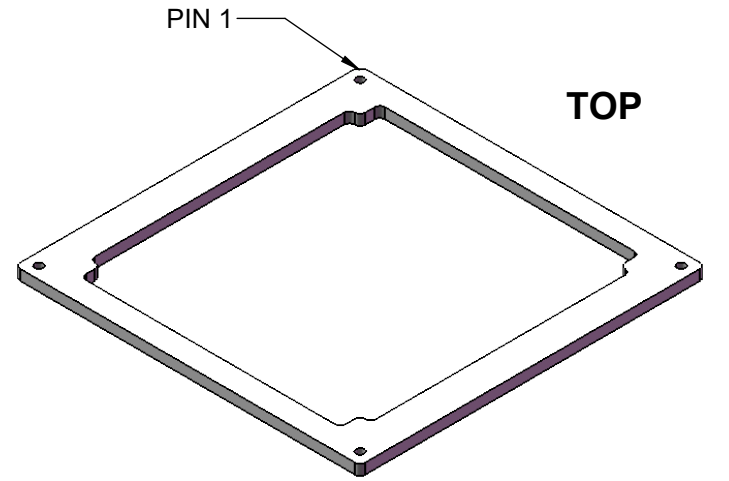
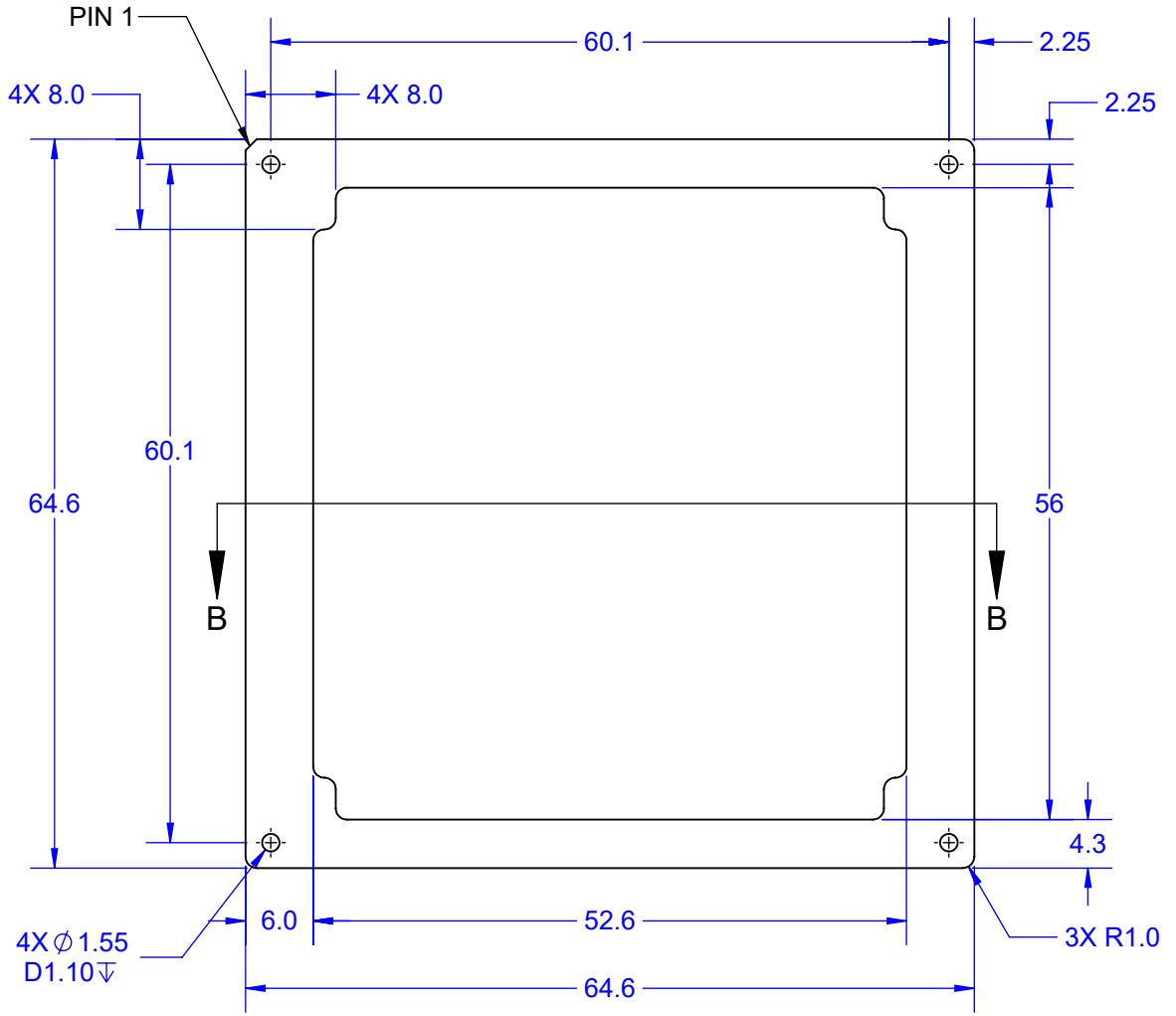

TOP

MODEL

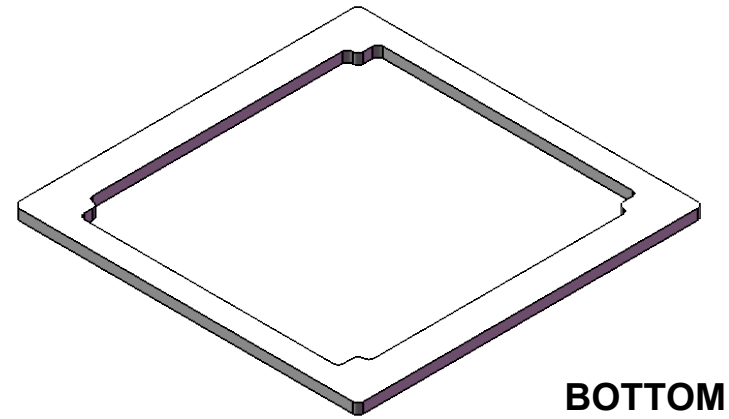

BOTTOM

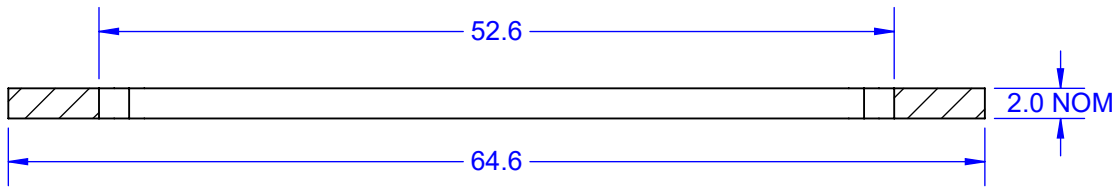

SECTION B-B
SCALE 2 : 1

APPROVALS	DATE				
DRAWN T. Au	7/16/2025				
ENG M. Hart	7/16/2025	TITLE X-STIF-65MM-A BGA STIFFENER			
MFG		SCALE 3:2	SIZE A	DRAWING NO. 206580	REV A
QA		DO NOT SCALE DRAWING			SHEET 4 OF 7
CUST					
REVISED					

MODEL

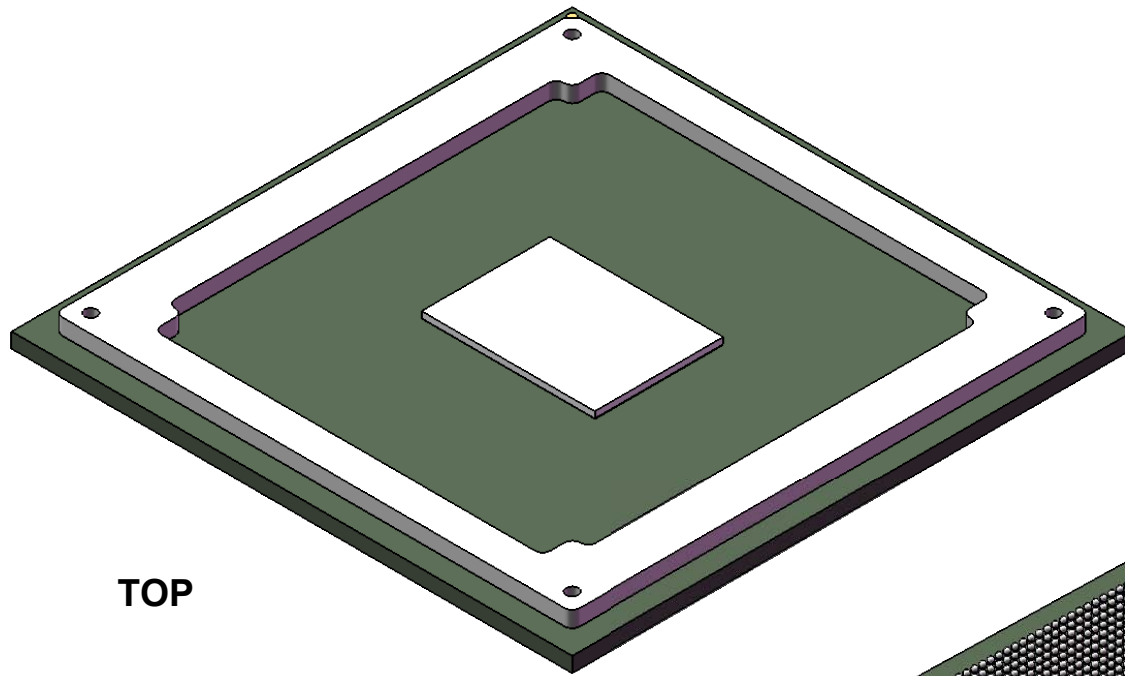

TOP

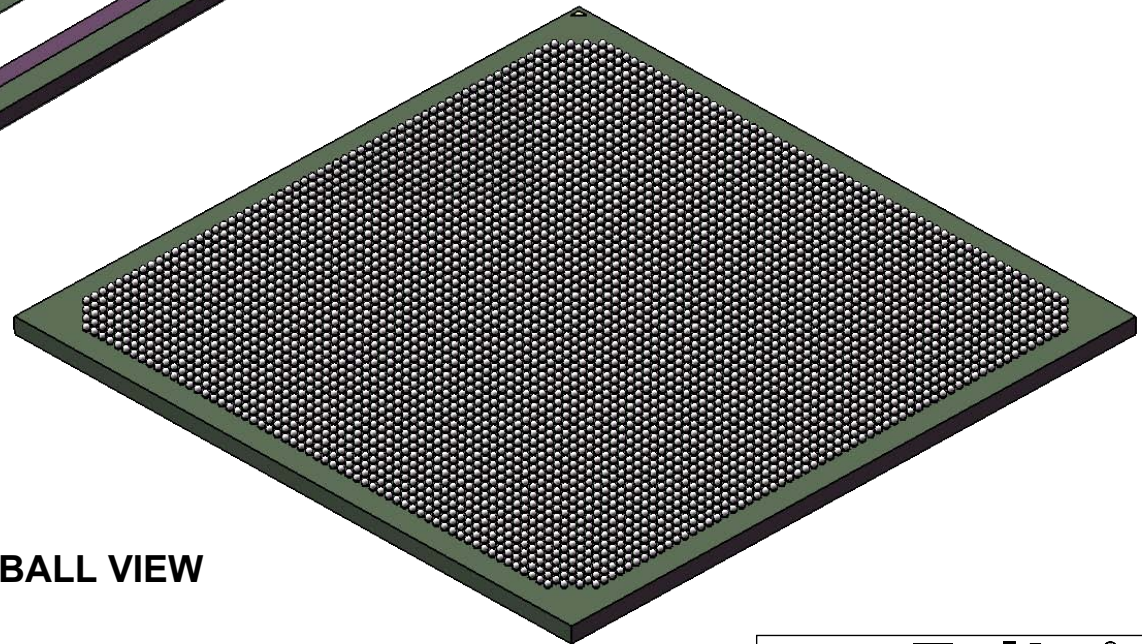

BALL VIEW

TopLine[®]

TITLE XBG4201T1.0-DC659D
DAISY CHAIN DUMMY

SCALE	SIZE	DRAWING NO.	REV
3:2	A	516596	A

DO NOT SCALE DRAWING

SHEET 5 OF 7

BOTTOM SOLDER MASK (RIGHT READING)

65 63 61 59 57 55 53 51 49 47 45 43 41 39 37 35 33 31 29 27 25 23 21 19 17 15 13 11 9 7 5 3 1
64 62 60 58 56 54 52 50 48 46 44 42 40 38 36 34 32 30 28 26 24 22 20 18 16 14 12 10 8 6 4 2

A
C B
E D
G F
J H
L K
N M
R P
U T
W V
Y
AA AB
AC AD
AE AF
AG AH
AJ AK
AL AM
AN AP
AR AT
AU AV
AW AY
BA BB
BC BD
BE BF
BG BH
BJ BK
BL BM
BN BP
BR BT
BU BV
BW BY
CA CB
CC CD
CE

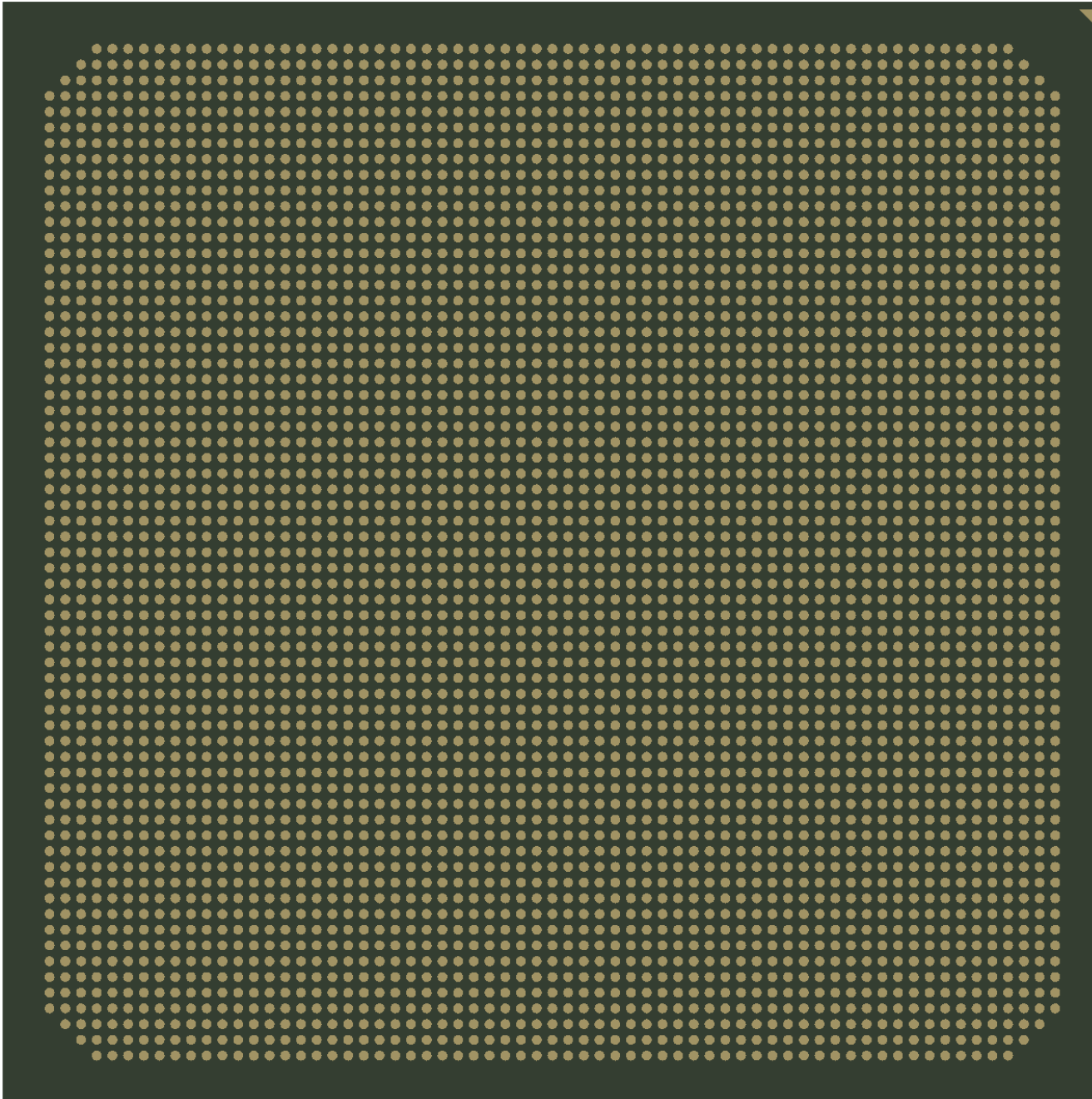

TopLine®			
TITLE		XBGA4201T1.0-DC659D DAISY CHAIN DUMMY	
SCALE	SIZE	DRAWING NO.	REV
2.5:1	A	516596	A
DO NOT SCALE DRAWING			SHEET 6 OF 7

VARIATIONS

VARIATION TABLE					
NOTES	PART SERIES	FINISH	BALL	ALLOY COMPOSITION	DESC
1	XBGA4201-420100	ImSn	SACQ	Sn92.45 Ag4.0 Cu0.5 Bi3.0 Ni0.05	Cyclomax
2	XBGA4201-516595	ENEPIG	SAC305	Sn96.5 Ag3.5 Cu0.5	M705NC
3	XBGA4201-420200	ENEPIG	SACQ	Sn92.45 Ag4.0 Cu0.5 Bi3.0 Ni0.05	Cyclomax
4	XBGA4201-420300	ENEPIG	iSAC	Sn Ag Cu Bi Ni Zn Ge	iSAC
5	XBGA4201-420400	ENEPIG	SAC305Ni	Sn96.45 Ag3.0 Cu0.5 Ni0.5	SACNi305005
6	XBGA4201-420500	ENEPIG	PF925	Sn Ag Cu In Bi X	PF925

TopLine®

TITLE XBGA4201T1.0-DC659D
DAISY CHAIN DUMMY

SCALE 2.5:1	SIZE A	DRAWING NO. 516596	REV A
----------------	-----------	-----------------------	----------

DO NOT SCALE DRAWING

SHEET 7 OF 7