

# 6CHCA J9K

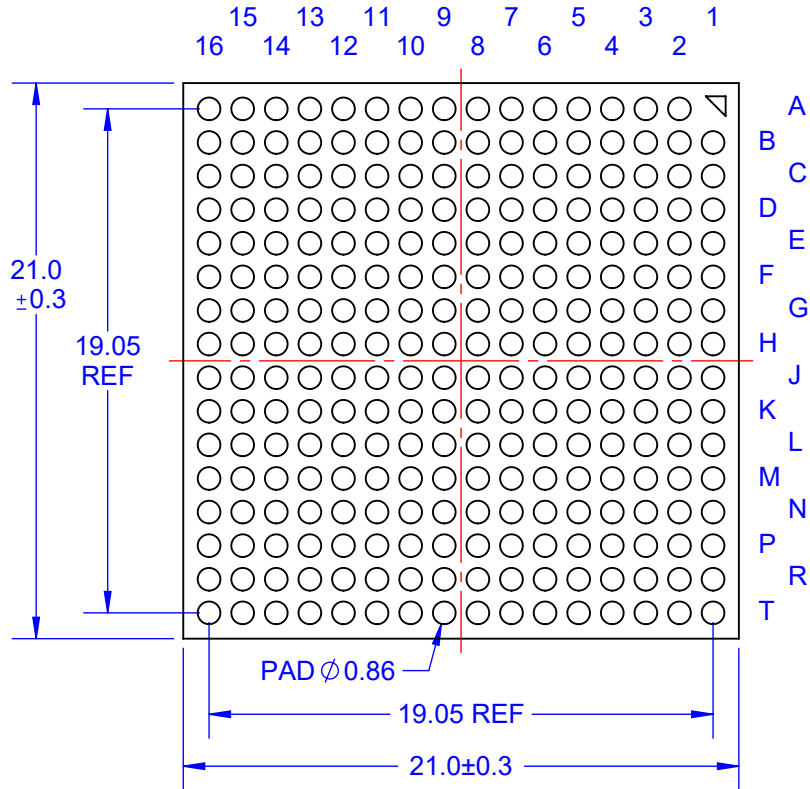

Pb90/Sn10  
Cu WRAP COLUMN

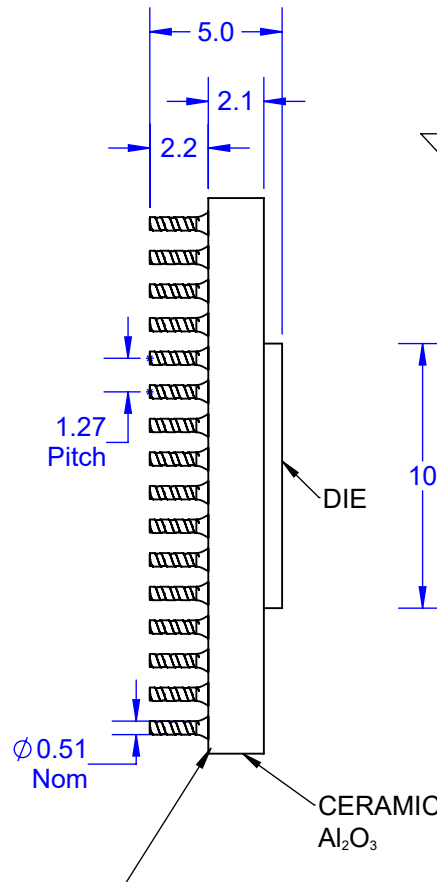
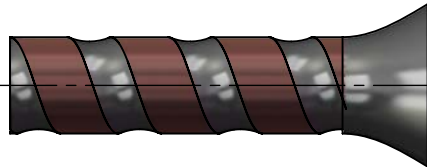

# HCD J9K

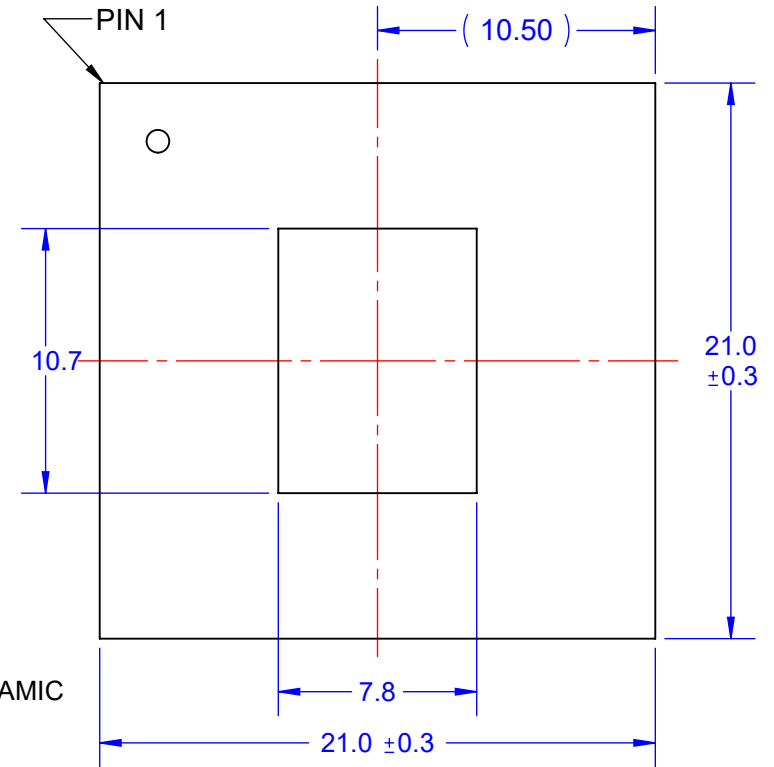

Notes: (Unless Otherwise Specified)

- 1) DIMENSION ARE IN mm.
- 2) SHOWN WITH Pb80/Sn20 Cu .
- 3) 255 COLUMNS.
- 4) DIE SIZE 10.7 x 7.8 x 0.9 MM.
- 5) PART NUMBER CCGA255T1.27-D.

D5FHBI A69F CDHCBG			
PART NUMBER	DUMMY DIE	SOLDER PIN	HS
CCGA255T1.27-D	YES	Pb80/Sn20 Cu RIBBON	NO

APPROVALS	DATE				
DRAWN T.Au	4/4/2021				
ENG M. Hart	4/4/2021	TITLE CCGA255T1.27-D COLUMN GRID ARRAY			
MFG					
QA		SCALE 3.5:1	SIZE A	DRAWING NO. 160032	REV A
CUST					
REVISED		DO NOT SCALE DRAWING			SHEET 1 OF 5

GC @ 9F D-B'DV, \$#Gb&\$

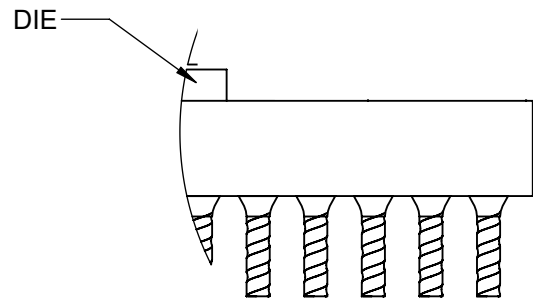
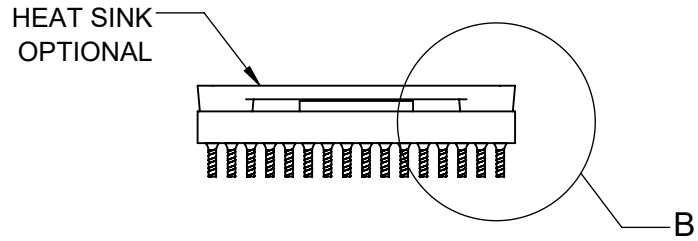

DETAIL B  
SCALE 6 : 1



Pb80/Sn20  
Cu RIBBON  
SCALE 15:1

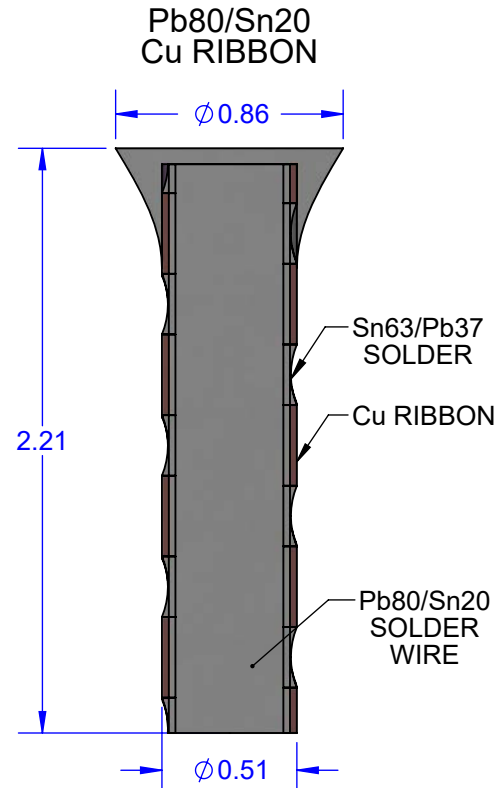

SECTION A-A  
SCALE 35 : 1

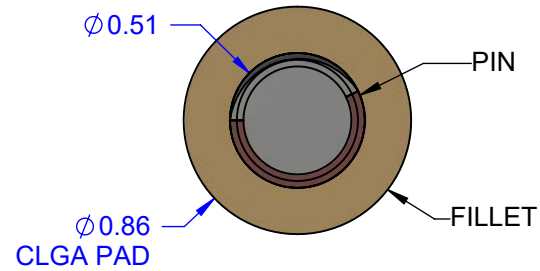

**TopLine**<sup>®</sup>

TITLE CCGA255T1.27-CN-D  
COLUMN GRID ARRAY

SCALE 1.75:1	SIZE A	DRAWING NO. 160032	REV A
-----------------	-----------	-----------------------	----------

DO NOT SCALE DRAWING

SHEET 2 OF 5

D58 'D5 HH9FB

7C@ AB'J9K

6CHCA 'L!F5MJ9K98': FCA 'HCD

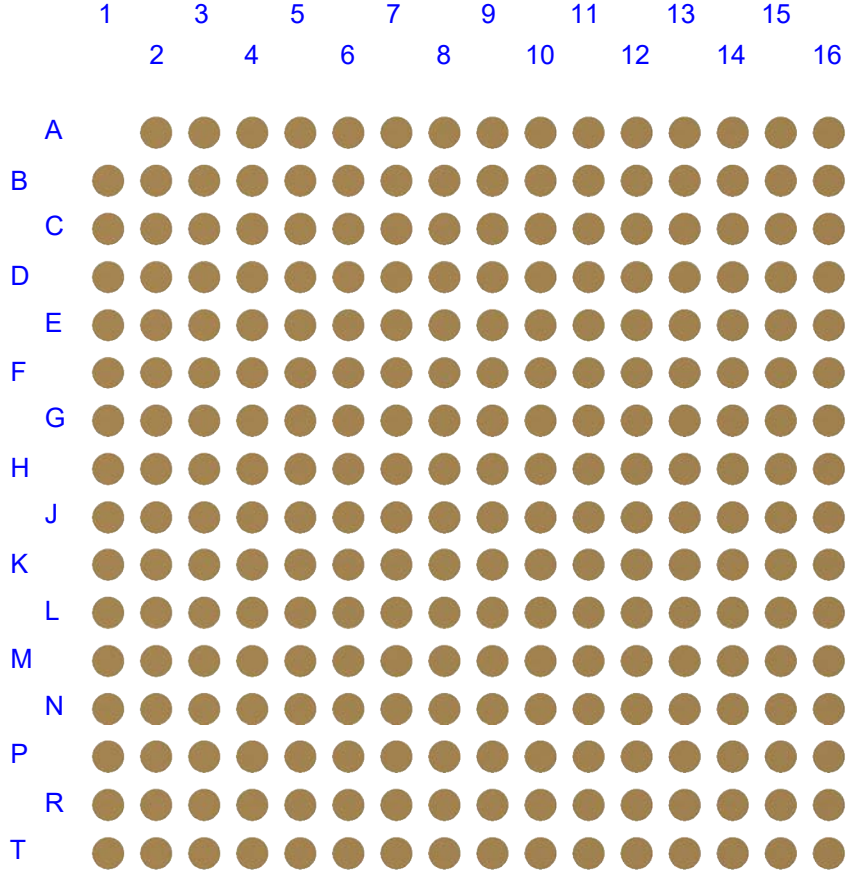
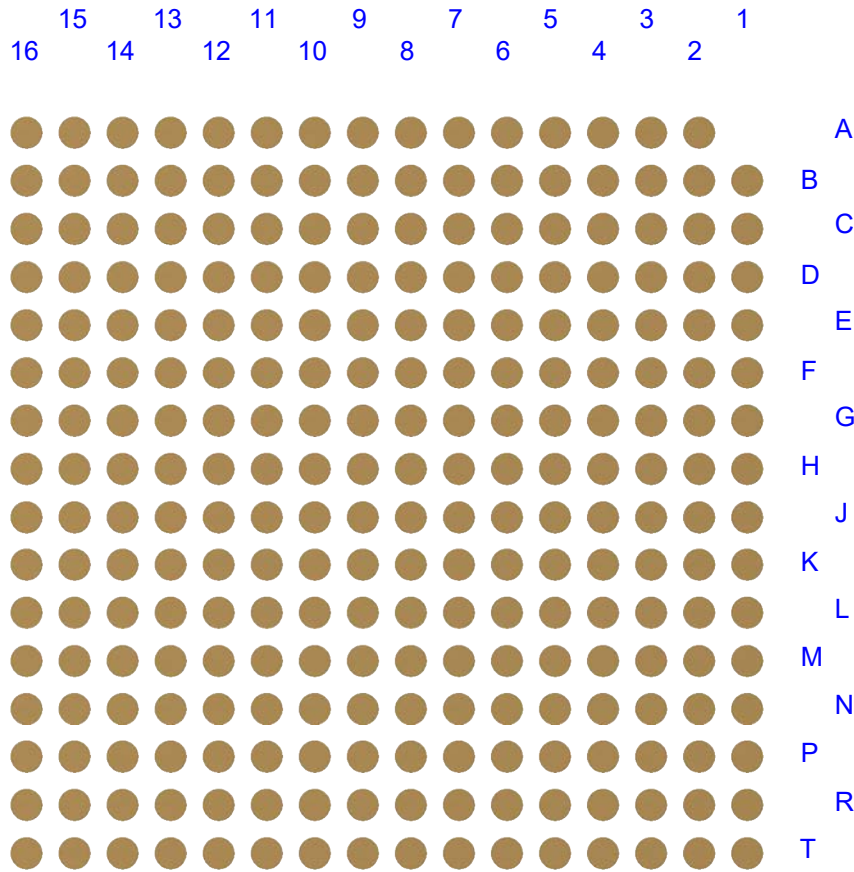

TITLE			
CCGA255T1.27-CN-D COLUMN GRID ARRAY			
SCALE	SIZE	DRAWING NO.	REV
2.75:1	A	160032	A
DO NOT SCALE DRAWING			SHEET 3 OF 5

AC89@  
K #k CI H < 95 H'G-B?

HCD

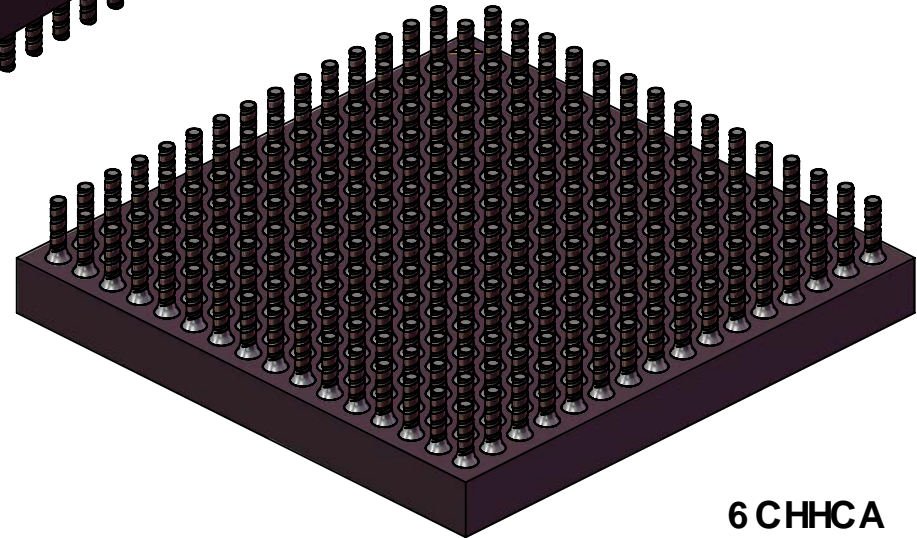
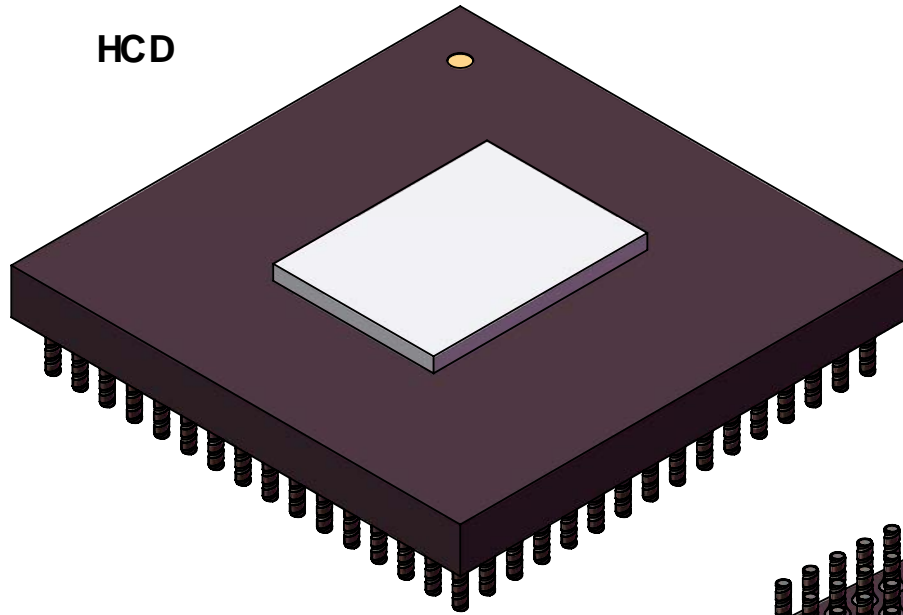

6 CHCA

<b>TopLine®</b>			
TITLE		CCGA255T1.27-CN-D COLUMN GRID ARRAY	
SCALE	SIZE	DRAWING NO.	REV
2.75:1	A	160032	A
DO NOT SCALE DRAWING			SHEET 4 OF 5

9LD@C898`J=9K  
 77; 5`HF5 M6 CL`GMGH9A  
 %!&+AA`D=H7 <

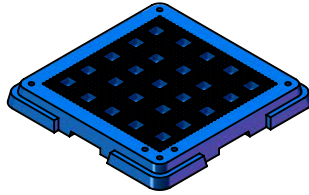

8K; '\$' &\$\$\$  
 6 @ 9`75 FF=9F  
 %\$`r`%\$`%&

5 GG9 A 6 @ 8



8K; `% \$%/\$`  
 =BG9FH`%\$(`r`%\$`)

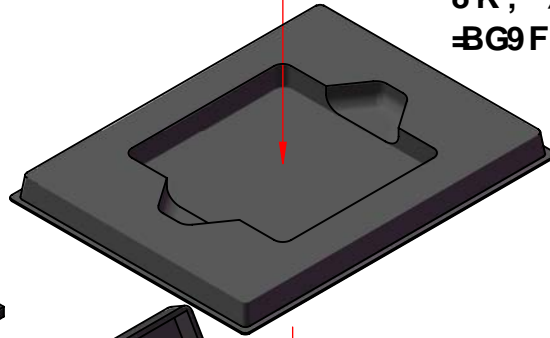

71 GHCA9F  
 @ 69 @



&L`8K; '\$-\$\$\$'  
 : C5A`%\$`r`%\$`

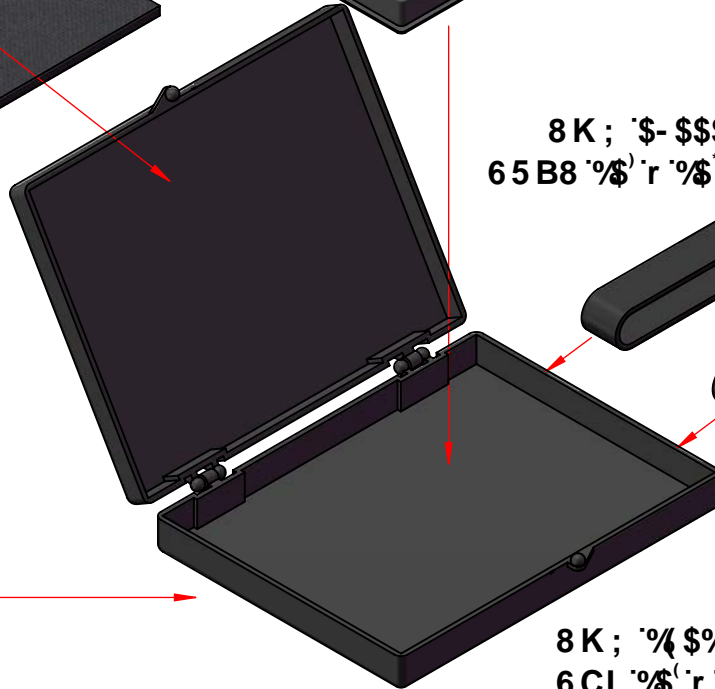

8K; '\$-\$\$\$)  
 65 B8`%\$`r`%\$`

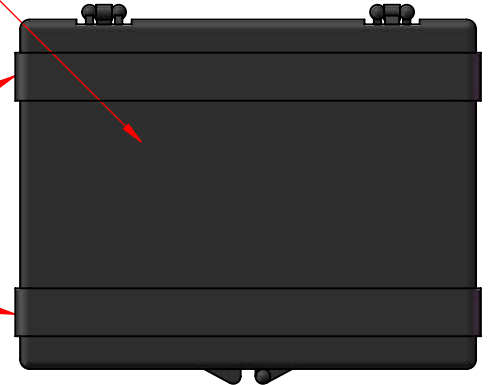

7 @CG98`6 CL

8K; '\$-\$\$\$-  
 =BG9FH`%\$`%&



8K; `% \$%/\$`  
 6 CL`%\$(`r`%\$`)

APPROVALS	DATE	<b>TopLine®</b>			
DRAWN T. Au	4/4/2021				
ENG M. Hart	4/4/2021	TITLE CCGA255 TRAY BOX BLUE CARRIER			
MFG		SCALE	SIZE	DRAWING NO.	REV
QA		1:2	A	932169	A
CUST		DO NOT SCALE DRAWING			SHEET 5 OF 5
REVISED					