

# Pb90/Sn10 SOLDER WIRE ELECTRODEPOSITED WITH Sn60/Pb40

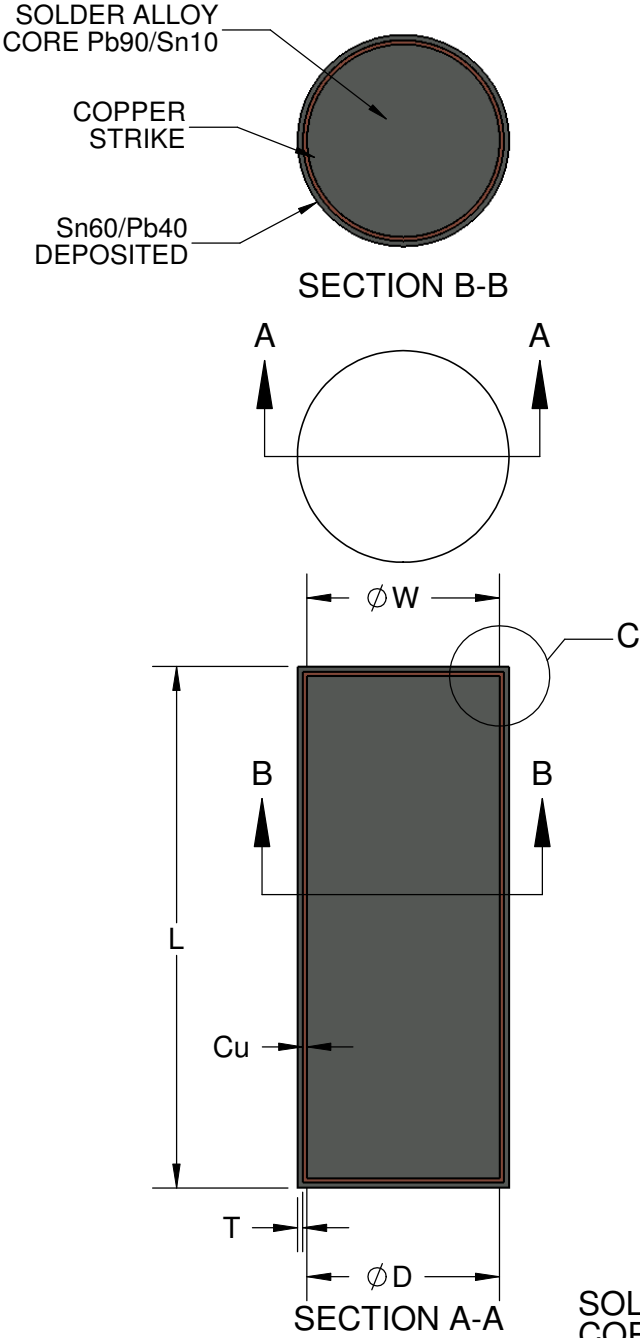

DIMENSION TABLE					
L Length (Inch)	$\phi D$ (Nominal) After Plating	$\phi W$ Solder Core $\pm 0.4\text{mil}$	Cu Nominal Copper Strike	T Nominal Sn60/Pb40 Matte	DWG
0.033" [0.84mm]	0.0082" [0.20mm]	0.0079" [0.20mm]	0.00005" [1.27 $\mu\text{m}$ ]	0.00015" [3.8 $\mu\text{m}$ ]	960833
0.040" [1.00mm]	0.0094" [0.24mm]	0.0091" [0.23mm]	0.00005" [1.27 $\mu\text{m}$ ]	0.00015" [3.8 $\mu\text{m}$ ]	960940
0.050" [1.27mm]	0.0102" [0.26mm]	0.0098" [0.25mm]	0.00005" [1.27 $\mu\text{m}$ ]	0.00015" [3.8 $\mu\text{m}$ ]	961050
0.065" [1.65mm]	0.0114" [0.30mm]	0.0110" [0.28mm]	0.00005" [1.27 $\mu\text{m}$ ]	0.00015" [3.8 $\mu\text{m}$ ]	961165
0.065" [1.65mm]	0.0122" [0.31mm]	0.0118" [0.30mm]	0.00005" [1.27 $\mu\text{m}$ ]	0.00015" [3.8 $\mu\text{m}$ ]	961265
0.067" [1.70mm]	0.0134" [0.34mm]	0.0130" [0.33mm]	0.00005" [1.27 $\mu\text{m}$ ]	0.00015" [3.8 $\mu\text{m}$ ]	961367
0.070" [1.80mm]	0.0142" [0.36mm]	0.0138" [0.35mm]	0.00005" [1.27 $\mu\text{m}$ ]	0.00015" [3.8 $\mu\text{m}$ ]	961470
0.075" [1.92mm]	0.0154" [0.39mm]	0.0150" [0.38mm]	0.00005" [1.27 $\mu\text{m}$ ]	0.00015" [3.8 $\mu\text{m}$ ]	941575
0.080" [2.03mm]	0.0162" [0.41mm]	0.0157" [0.40mm]	0.00005" [1.27 $\mu\text{m}$ ]	0.00015" [3.8 $\mu\text{m}$ ]	961680
0.080" [2.03mm]	0.0173" [0.44mm]	0.0169" [0.43mm]	0.00005" [1.27 $\mu\text{m}$ ]	0.00015" [3.8 $\mu\text{m}$ ]	961780
0.080" [2.03mm]	0.0181" [0.46mm]	0.0177" [0.45mm]	0.00005" [1.27 $\mu\text{m}$ ]	0.00015" [3.8 $\mu\text{m}$ ]	961880
0.087" [2.21mm]	0.0200" [0.51mm]	0.0197" [0.50mm]	0.00005" [1.27 $\mu\text{m}$ ]	0.00015" [3.8 $\mu\text{m}$ ]	962087
0.100" [2.54mm]	0.0200" [0.51mm]	0.0197" [0.50mm]	0.00005" [1.27 $\mu\text{m}$ ]	0.00015" [3.8 $\mu\text{m}$ ]	962099

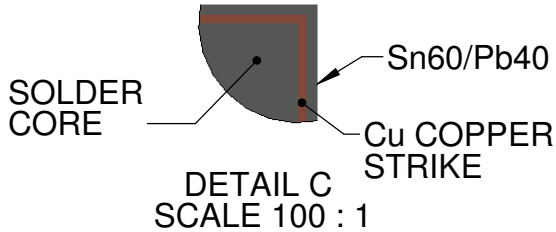

Notes: (Unless Otherwise Specified).  
1) Cu STRIKE AND PLATING ON ALL SIDES INCLUDING ENDS.

APPROVALS	DATE	<b>TopLine</b> ®			
DRAWN J. Hines	8/11/2014	TITLE Pb90/Sn10 Solder Column Plated with Sn60/Pb40			
ENG M. Hart	8/11/2014				
MFG		SCALE	SIZE	DRAWING NO.	REV
QA		50:1	A	168005	A
CUST		DO NOT SCALE DRAWING			SHEET 1 OF 1
REVISED					