

EXTERIOR VIEW

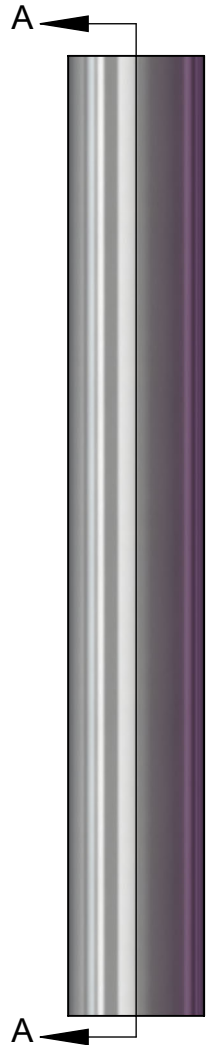

SECTION VIEW

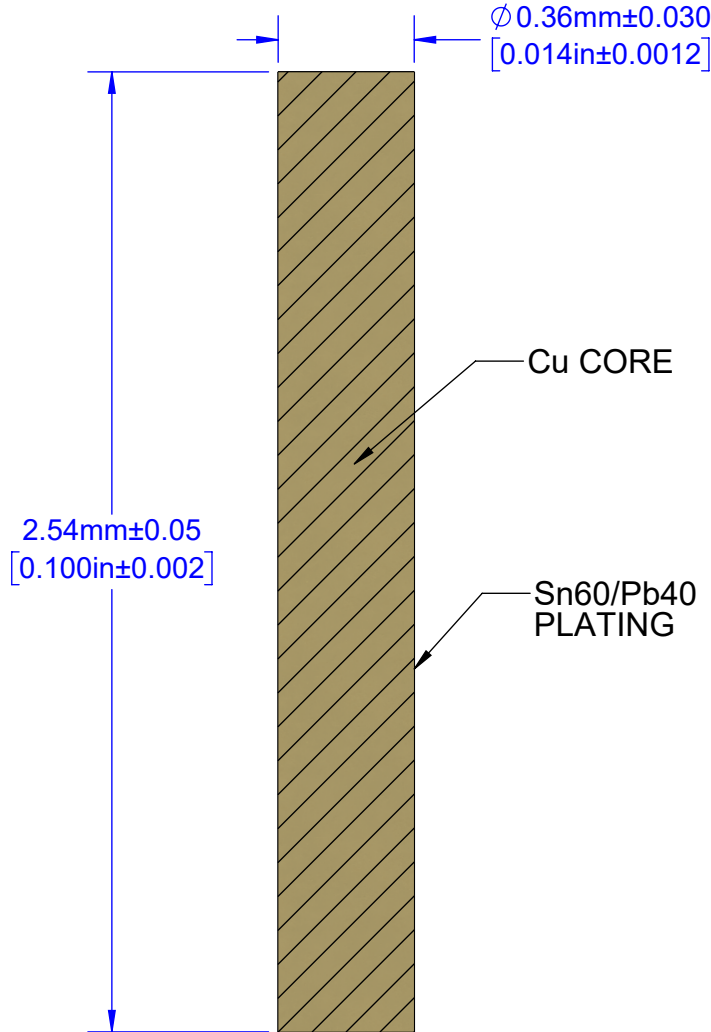

CCGA - LAND PAD

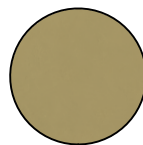
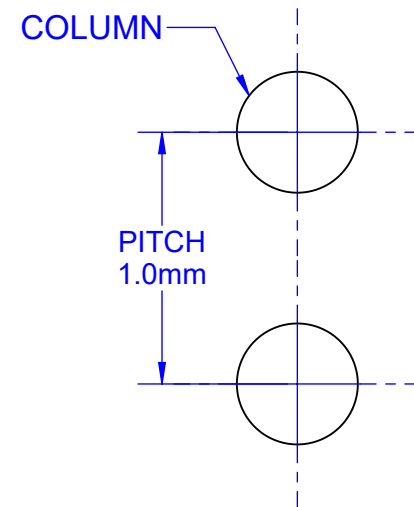
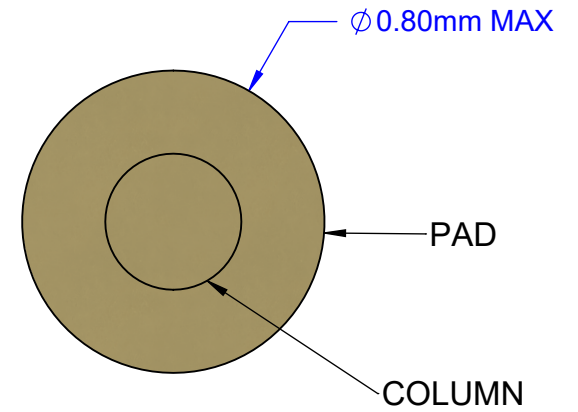

END VIEW

- Notes: (Unless Otherwise Specified).
 1) DIMENSIONS IN mm [INCHES].
 2) MATERIAL: Cu COPPER ALLOY CDA101 OFE-OFHC.
 3) PLATING: Sn60/Pb40 3.0~5.0µm [100~200 MICRO-INCH].
 4) WIRE GAUGE: AWG27.

APPROVALS	DATE	TopLine®			
DRAWN T. Au	01/13/18				
ENG M. Hart	01/13/18	TITLE CU101P14x100 CCGA COPPER COLUMN			
MFG		SCALE	SIZE	DRAWING NO.	REV
QA		50:1	A	301499	A
CUST		DO NOT SCALE DRAWING			SHEET 1 OF 1
REVISED					